

BREMACH

S.r.l.

VEICOLI INDUSTRIALI

Nuovo motore **EURO 3**

New engine **EURO 3**

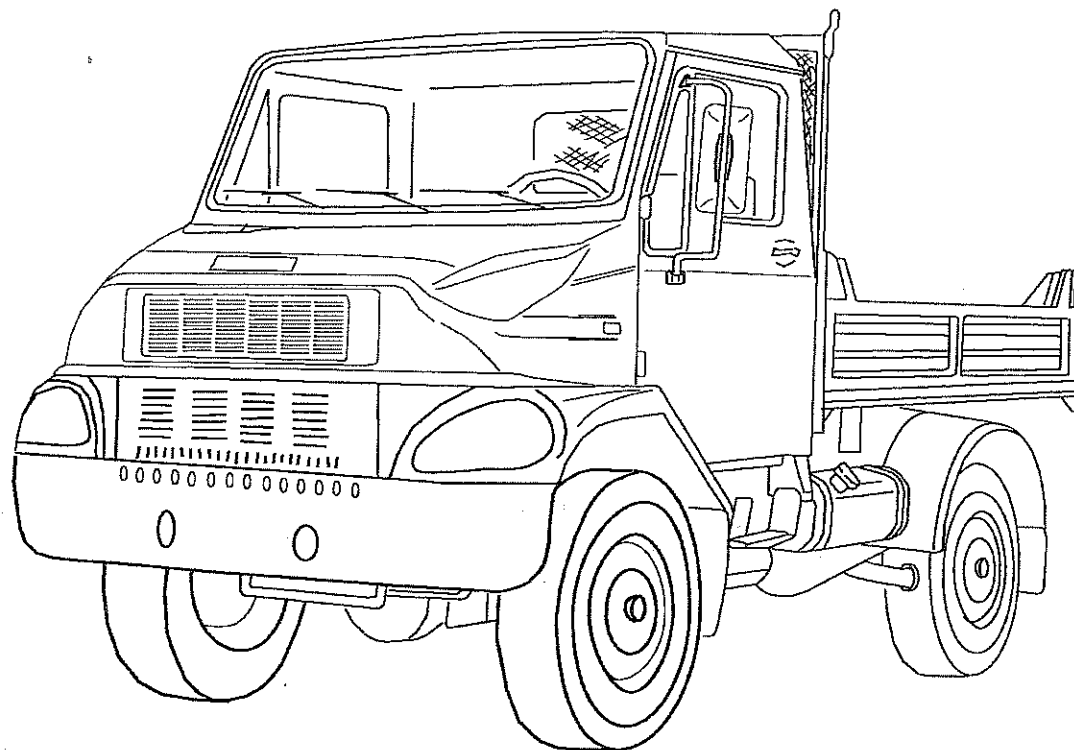

EXTREME

Catalogo parti di ricambio **EXTREME**

EXTREME

Spare parts list for **EXTREME**

Modalita' di aggiornamento periodico del catalogo ricambi

Il catalogo è aggiornato con periodicità semestrale (aprile - ottobre).

Ad ogni scadenza, BREMACH S.r.l. spedisce i relativi aggiornamenti costituiti dalle sole tavole oggetto di modifiche e da un nuovo indice alfanumerico completo.

L'indice riporta l'elenco di tutte le tavole con la loro edizione più recente (vedi, colonna <edizione>).

I destinatari degli aggiornamenti devono sostituire il vecchio indice alfanumerico con il nuovo e, analogamente le vecchie tavole con le nuove.

Nota: Si consiglia di archiviare le vecchie tavole, a parte, e in ordine progressivo, alla fine del catalogo; questo permette di rintracciare pezzi di ricambio anche di veicoli con numero di telaio precedente alle modifiche.

Si ricorda che è sempre possibile controllare lo stato di aggiornamento del proprio catalogo, verificando che l'edizione di ogni tavola corrisponda a quella riportata nell'ultima edizione dell'indice alfanumerico.

Eventuali tavole che risultassero non aggiornate possono essere richieste a BREMACH S.r.l.

Terms of periodic update of the spare-parts' catalogue

The catalogue is updated each six months (april-october).

At each maturity, BREMACH S.r.l. will deliver the concerning new editions which will regard only the tables subject to modifications and a new and complete alphanumerical index.

The index will contain the list of all tables together with the most recent edition (see column <edition>).

The addressees of the updated editions shall substitute the old alphanumerical index with the new one and, likewise the old tables with the new ones.

Note: We suggest you to file the old tables separately, with a progressive order, and at the end of the catalogue; this will allow you to find the spare-parts even of vehicles with a number of chassis previous to modifications.

We remind you that at any time you can check the state of update of your own catalogue by examining that the edition of each table corresponds to the one mentioned in the last alphanumerical index edition.

Eventual tables that might turn out to be not updated, can be requested to BREMACH S.r.l.

EXTREME

Nuovo motore EURO 3
New engine EURO 3

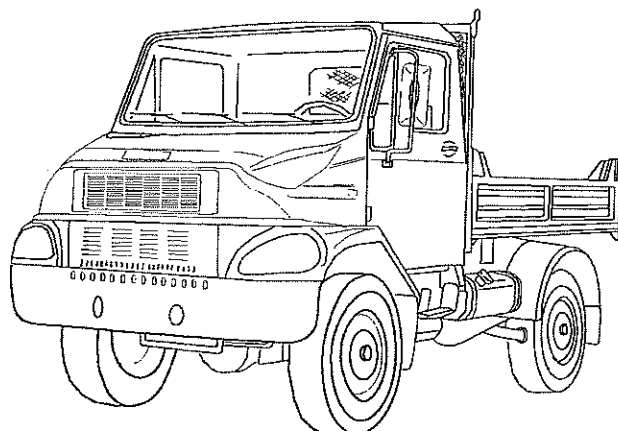
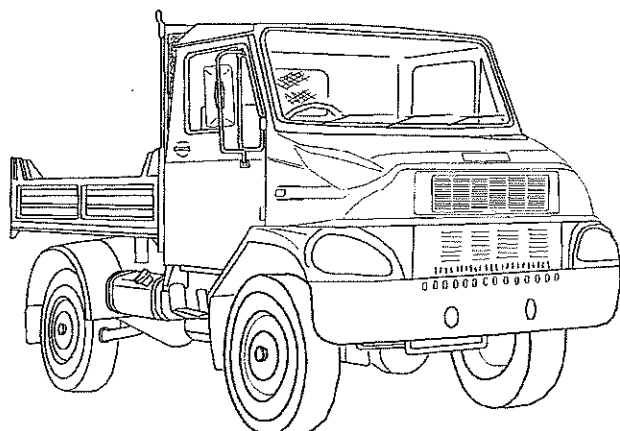

Catalogo parti di ricambio **EXTREME** e derivati
Spare parts list for **EXTREME** trucks and derived

BREMACH

S.r.l.

Via Pacinotti, 37 • 21100 Varese • Italia • Tel. 39 0332 / 802911 • Fax 39 0332 / 491229
Web: <http://www.bremach.it> • E-Mail: bremach@bremach.it

INTRODUZIONE

Il presente catalogo è la guida per l'ordinazione delle parti di ricambio ed è stato realizzato tenendo conto di due esigenze fondamentali:

- a) consentire una rapida identificazione della macchina in tutte le sue versioni e quindi una rapida individuazione dei pezzi che la compongono.
- b) consentire l'aggiornamento periodico mediante la sostituzione o l'aggiunta di figure.

Le istruzioni, i disegni, le tabelle e quant'altro è contenuto nel presente fascicolo sono di natura tecnica riservata e, per questo, ogni informazione non può essere riprodotta nè completamente nè parzialmente e non può essere comunicata a terzi senza l'autorizzazione scritta della BREMACH S.r.l. che ne è la proprietaria esclusiva e che si riserva il diritto di apportare senza preavviso tutte quelle modifiche che riterrà opportune.

BREMACH

INTRODUCTION

This Catalogue has the function of a guide to order spare-parts and it has been conceived while considering two basic requirements:

- a) to allow a fast identification of all types of vehicles and therefore a quick singling out of the parts of which they are composed.
- b) to allow a periodic update through the replacement or the addition of pictures.

All the instruction, the drawings, the schedules and anything else represented in this dossier are technically reserved nature and, for this reason, any information can not be reproduced either fully or partially and can not be transmitted to third ones without a written authorization issued by Bremach, which is the exclusive owner and as such, without notice, might reserve the right to make all changes she'll deem necessary.

BREMACH

GUIDA ALLA CONSULTAZIONE

Sulla tavola contenente la figura e sulla distinta sono indicate:

- a) il n° della tavola comprende il gruppo di appartenenza, ad esempio Tav "10.28", la tavola appartiene al gruppo "10" ed è la tavola "28";
- b) il titolo della tavola;
- c) l'edizione di realizzazione della tavola;
- e) al piede della tavola è indicata la versione di autotreno per cui la tavola è stata realizzata. L'indicazione della validità è rappresentata dal quadratino annerito "■" vicino al pittogramma; ad esempio:

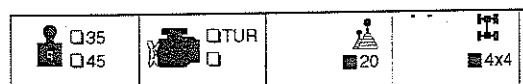

questa tavola è valida per il Mod. a 20 marce con trazione 4x4.

I pittogrammi rappresentati al piede della pagina hanno il seguente significato:

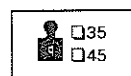

portata 35q o portata 45q

CONSULTING GUIDE

On the table showing the picture and on the part list you'll find:

- a) the nr. of the table which includes the group to which it belongs, for example Table "10.28" means that it belongs to the group "10" and the table is "28";
- b) the title of the table;
- c) date of table's issue;
- e) at the foot of the table it is shown the truck type for which the table is conceived.

The applicability is countersigned through a black square sign positioned near the picture, for example:

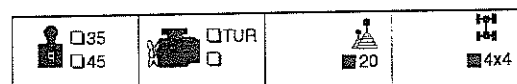

this table is valid for the type equipped with 20 gears with a four-wheel drive 4x4 traction.

The meaning of the pictures shown at the foot of each page is:

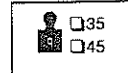

35q capacity or 45q capacity

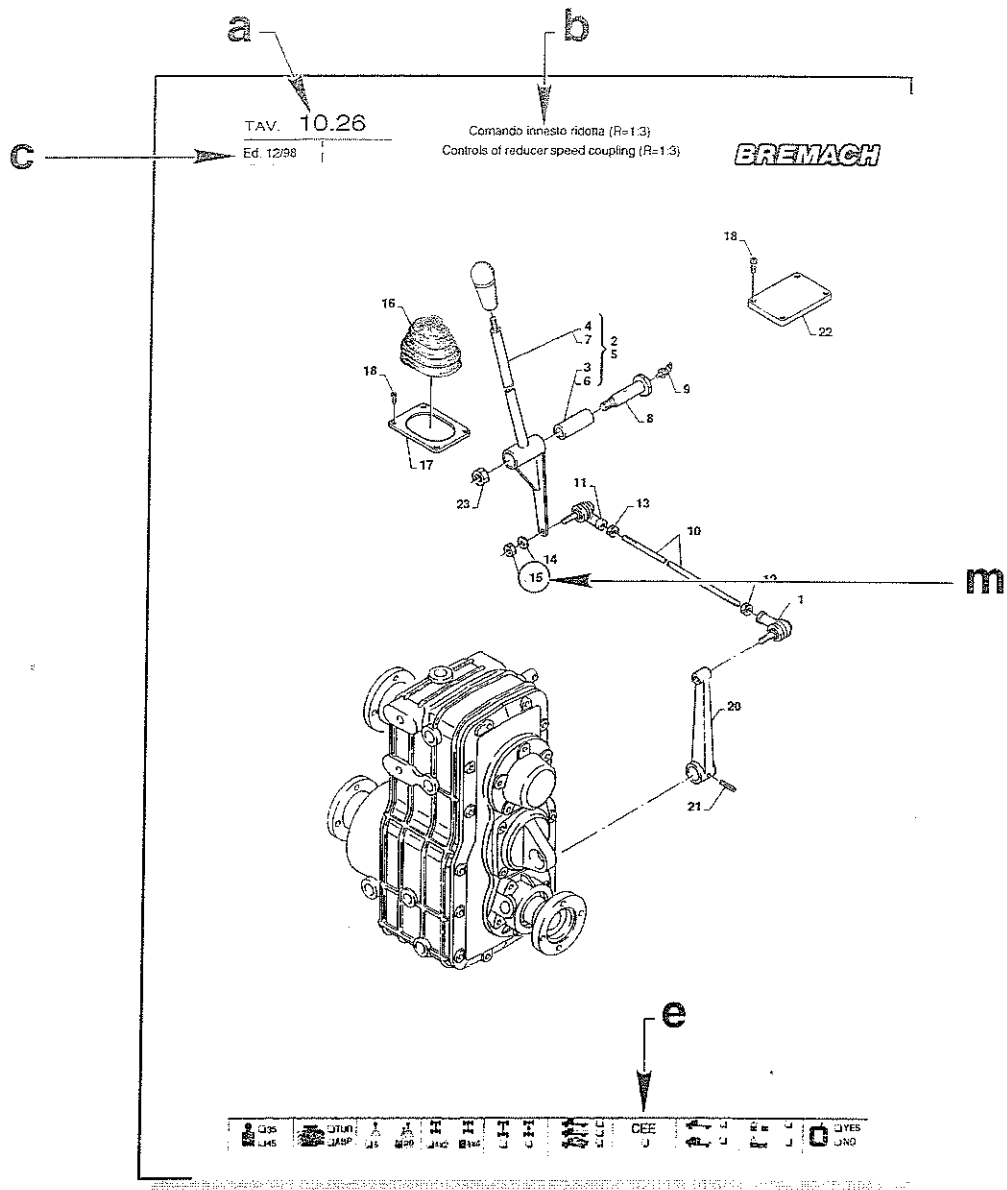

N. Pos.	COD.	DENOMINAZIONE	Q.ty	DESCRIPTION	Da materiale Serial number
1	83573	Snodo destro per colleg. asta innvio	1	...	200001
2	90L3015	Assieme leva innesto 2 posti	1	...	200001
3	80934	Boccola 16x21x60	1	...	200001
5	90L3018	Assieme leva innesto 3 posti	1	...	200001
6	80934	Boccola 16x21x60	1	...	200001
7	90L3017	Leva innesto	1	...	200001
9	D4032	Ingrassatore AL	1	...	200001
10	90L3009	Asta di innvio comando di innesto ridotta	1	...	200001
11	83574	Snodo sx IKO per colleg. asta di innvio comando	1	...	200001
12	83372	Dado M8 sx per colleg. asta di innvio comando	1	...	200001
13	202012	Dado M8 UNI 5598-65	1	...	200001
15	202004	Dado M8 UNI 5597-68 per colleg. asta innvio	1	...	200001
17	90L3005	Cornice montaggio cuffia	1	...	200001
18	204001	Vite autosaltante	1	...	200001
19	90L3011	Pomolo leva innesto ridotta (1.3)	1	...	200001
20	90F1055	Leva innesto al riduttore	1	...	200001
21	80677	Spina elastica 6x3 UNI 5873	1	...	200001
22	90F1012	Coperchio	1	...	200001
23	202006	Dado M12	1	...	200001

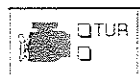

tipo di motore "TUR" turbo E3 ;

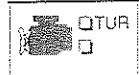

type of engine: "TUR" Turbo E3 engine



quantita' di marce 20;



gear number: 20;

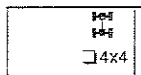

tipo di trazione 4x4;

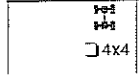

traction: 4x4

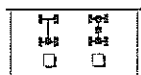

blocco differenziale solo posteriore o totale;

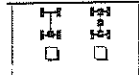

differential locking: only on the rear axle or on both;

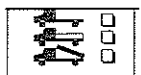

tipo di versione, solo autotelaio, con cassone fisso, con cassone ribaltabile;

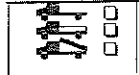

configuration: only chassis, cargo bed, kipper;

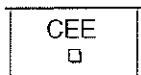

se la tavola é per la versione omologata CEE;

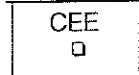

table refered to the CEE homologated configuration or not;



tipo di cabina semplice o doppia;



type of cabin: simple or double;

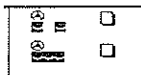

2 posti anteriori o 3 posti anteriori;



2 or 3 front seats;



con gancio di traino ulpio.

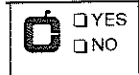

with ulpio towing hook with eptapolar socket.

Sulla distinta é indicato:

- f) il n° di posizione del particolare rappresentato in figura;
- g) il numero di codice del particolare;
- h) la descrizione del particolare;
- i) la quantita' di pezzi del particolare all'interno della tavola;
- l) la validita' del particolare da matricola telaio in poi;
- m) nella tavola contenente la figura i pezzi sono numerati in modo progressivo, quindi ricercare il pezzo desiderato e tramite la posizione e leggere sulla distinta a fianco il codice, la descrizione, la quantita' e la validita' da matricola telaio.

On the part list it is clearly shown:

- f) the Position number refered to the item shown in the picture;
- g) the Part number refered to the item;
- h) the item description;
- i) the quantity of pieces in the assemblies shown in the picture;
- l) the applicability of the item defined by the chassis number starting from which the item has been installed and, if need, by the chassis number starting from which the item no more is in the truck configuration;
- m) in the table representing the picture, the items are progressively numbered; therefore, look for the desired item and through the position read on the "part list" given aside the drawing, the code, the description, the quantity and the validity learnt from the serial number of the chassis.

NOTA:

Nella distinta, i gruppi e i KIT sono riconoscibili perchè i componenti del gruppo sono preceduti da un punto e sono tutti elencati immediatamente sotto un elemento privo di punto che ne è il capostipite il cui nome e codice identificano il kit stesso. Vedere didascalia zone "n" e "o".

NOTE:

Inside the part list, you can recognise item groups or kits because the kit components have a dot before them and all these components are listed immediately below an item without dot. This item, on the top of the dotted ones listed below, is identified by a name and a code that identifies also the group/kit itself.

See notes "o" and "n" in the previous table.

MODALITÀ DI ORDINAZIONE

Per facilitare la ricerca di magazzino e la spedizione dei pezzi di ricambio si pregano i Sig. Clienti di attenersi alle seguenti norme e di specificare sempre:

- Modello, matricola del telaio e anno di costruzione della macchina.
- Quantit  di pezzi desiderati.
- Numero di posizione e numero della tavola.
- Codice di ordinazione e denominazione del particolare.
- Indirizzo esatto e ragione sociale del Committente, completato con l'eventuale recapito per la consegna della merce.
- Mezzo di spedizione desiderato. (Nel caso questa voce non sia specificata, la BREMACH si riserva di usare a sua discrezione il mezzo pi  opportuno).

NOTA:

Gli automezzi **BREMACH** sono garantiti per **36 mesi** dall'acquisto. In caso di acquisto di pezzi di ricambio consultare la **CARD** fornita con i documenti veicolo, se la garanzia fosse ancora attiva ordinare seguendo le istruzioni del "**MANUALE SERVIZIO GARANZIE BREMACH**".

ORDER PROCEDURE

In order to enable the search of spare-parts in our storehouse as well as their delivery, customers are always kindly requested to conform to the following rules and to state precisely:

- Type serial number of the chassis, and year of vehicle's construction.
- Quantity of the desired items.
- Position and table number.
- Order code and name of the item.
- Right address and style of the buyer, including the eventual address of goods delivery.
- Desired means of transport. (Whenever this information should lack, Bremach, on its discretion, reserves the right to use the most suitable one she deems).

NOTE:

BREMACH trucks have a 36 month guarantee starting from the purchasing date. Therefore, in case of need of spare parts, check the guarantee **card**; should the guarantee be still active the orders shall be done following the procedure stated on "**BREMACH GUARANTEE SERVICE MANUAL**".

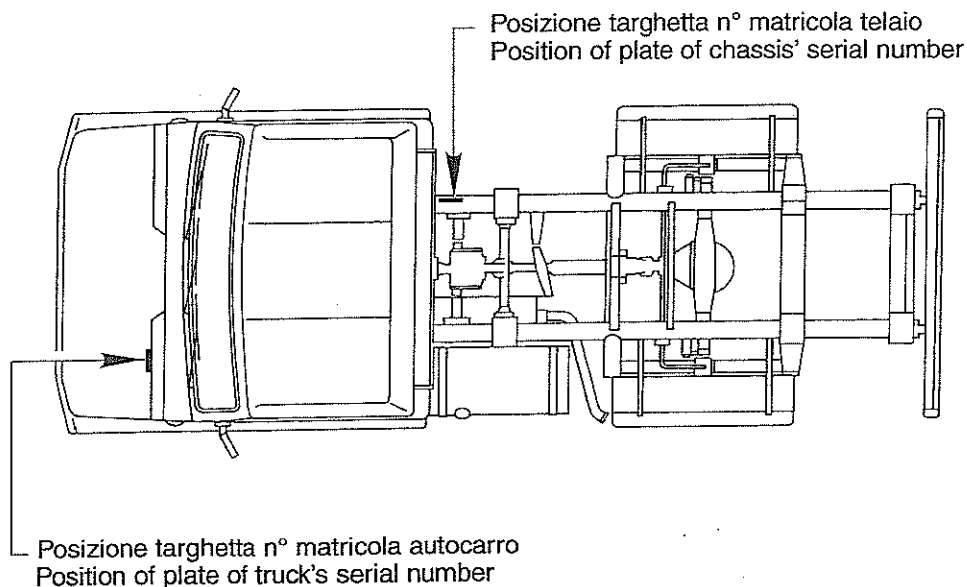

EXTREME INDICE**GRUPPO 0**

Motore-Frizione-Cambio	
Supporto anteriore motore	
Supporto posteriore motore	
Tubazioni di scarico	
Tubazioni di scarico	
Filtro aria	
Vaso di espansione e tubazioni	
Radiatore	
Impianto combustibile	

GRUPPO 10

Alberi di trasmissione passo 2600	
Alberi di trasmissione passo 3000	
Riduttore ripartitore (albero superiore)	
Riduttore ripartitore (albero intermedio)	
Riduttore ripartitore (albero inferiore)	
Riduttore ripartitore centrale (innesto avantreno)	
Comando innesto ripartitore/riduttore (r=1:1,3)	
Comando innesto ridotta (r=1:3)	
Comando innesto avantreno	
Supporti riduttore	
Assale posteriore	
Assale posteriore	
Assale anteriore	
Assale anteriore	
Differenziale posteriore	
Differenziale anteriore	
Differenziale anteriore	
Scatola porta satelliti	
Tiranteria bloccaggio differenziale posteriore	
Tiranteria bloccaggio differenziale anteriore	

GRUPPO 20

Ponte posteriore completo	
Ponte posteriore (struttura portante)	
Ponte anteriore completo	
Ponte anteriore (struttura portante)	

GRUPPO 30

Sospensione anteriore	
Barra stabilizzatrice anteriore	
Sospensione posteriore	
Barra stabilizzatrice posteriore	
Cerchi e ruote	

EXTREME INDEX**GROUP 0**

Engine-Friction clutch-Gearbox	TAV. 0.13
Engine-Friction clutch-Gearbox	TAV. 0.21
Front motor support	TAV. 0.22
Rear motor support	TAV. 0.31
Exhaust pipes	TAV. 0.32
Air filter	TAV. 0.42
Water reservoir and tube	TAV. 0.51
Radiator	TAV. 0.521
Fuel system	TAV. 0.61

GROUP 10

Prop shafts weel base 2600	TAV. 10.12
Prop shafts weel base 3000	TAV. 10.13
Reduction gearbox (up shaft)	TAV. 10.21
Reduction gearbox (center shaft)	TAV. 10.22
Reduction gearbox (down shaft) ..	TAV. 10.23
Reduction gearbox (forecarriage coupling)	TAV. 10.24
Control of reduction gear box coupling (R=1:1,3)	TAV. 10.25
Controls of reducer speed coupling (R=1:3)	TAV. 10.26
Forecarriage coupling control	TAV. 10.27
Reduction gear box supports	TAV. 10.283
Rear axle	TAV. 10.311
Rear axle	TAV. 10.312
Front axle	TAV. 10.322
Front axle	TAV. 10.323
Rear differential	TAV. 10.412
Front differential	TAV. 10.421
Front differential	TAV. 10.422
Planetary box	TAV. 10.43
Rear differential interlock linkage ..	TAV. 10.441
Front differential interlock linkage ..	TAV. 10.442

GROUP 20

Complete rear axle	TAV. 20.11
Rear axle (cerryng structure)	TAV. 20.12
Complete front axle	TAV. 20.21
Front axle (cerryng structure)	TAV. 20.221

GROUP 30

Front-wheel suspension	TAV. 30.11
Front main anti-roll bar	TAV. 30.122
Rear-wheel suspension	TAV. 30.21
Rear main anti-roll bar	TAV. 30.22
Rims and wheels	TAV. 30.3

BREMACH

GRUPPO 40

Impianto frenante anteriore	
Freno a disco	
Impianto frenante posteriore	
Freni a tamburo	
Tiranteria freno a mano	

GRUPPO 50

Volante e comandi	
Idroguida/piantone sterzo	
Idroguida/comando alle ruote	
Idroguida/servoattuatore idraulico	
Idroguida/connessioni idrauliche	

GRUPPO 60

Cabina semplice	
Cabina doppia	
Portiera anteriore dx e-sx	
Vetri e guarnizioni per portiera	
Portiere laterale dx	
Componenti vari cabina singola	
Componenti vari cabina doppia	
Vetri e guarnizioni cabina singola	
Vetri e guarnizioni cabina doppia	
Rivestimenti interni cabina singola	
Rivestimenti interni cabina doppia	
Allestimenti interni cabina	
Allestimenti interni cabina (cruscotto)	
Pedaliera e gruppo poggiatesta	
Sedili e cinture di sicurezza (2 posti anteriore)	
Sedili e cinture di sicurezza (3 posti anteriori)	
Sedili e cinture di sicurezza (3 posti anteriori)	
Insonorizzazione vano motore	
Insonorizzazione cabina	
Tergicristallo e lavacrystallo	

GRUPPO 70

Comandi riscaldamento	
Comandi riscaldamento - Condizionatore	

GRUPPO 80

Comando di presa di forza sul cambio	
Presa di forza posteriore sul riduttore con pompa idraulica	
Presa di forza anteriore su motore	
Impianto Stanley	
Presa di forza posteriore su riduttore	
Comando presa di forza superiore	
Riduttore a 20 rapporti e alberi di trasmissione	
Cassone ribaltabile trilaterale	
Attivazione cassone ribaltabile (connessioni idrauliche)	

GROUP 40

Front braking system	TAV	40.11
Disk brake	TAV	40.111
Rear braking system	TAV	40.12
Drum brake	TAV	40.13
Parking brake linkage	TAV	40.21

GROUP 50

Steering colon and driving controls	TAV	50.11
HPS / steering colon	TAV	50.12
HPS / wheel control	TAV	50.13
HPS / servoactuator	TAV	50.21
HPS / hidraulic connection	TAV	50.22

GROUP 60

Simple cab	TAV	60.11
Double cab	TAV	60.12
Right and left door (front)	TAV	60.131
Windows and door weather strips	TAV	60.132
Right side door	TAV	60.141
Simple cab various components ..	TAV	60.151
Double cab various components ..	TAV	60.152
Simple cab windows and gasket ..	TAV	60.21
Double cab windows and gasket ..	TAV	60.22
Simple cab inside panels	TAV	60.31
Double cab inside panels	TAV	60.32
Insert cab parts	TAV	60.41
Cab instruments	TAV	60.42
Pedal bracket and foot rest assy ..	TAV	60.43
Seats and safety belts (2 front seats) ..	TAV	60.511
Seats and safety belts (3 front seats) ..	TAV	60.512
Seats and safety belts (3 rear seats) ..	TAV	60.52
Sound insulation in engine area ..	TAV	60.61
Cab sound insulation	TAV	60.62
Wiper-washer equipment	TAV	60.7

GROUP 70

Heating controls	TAV	70.1
Heating controls - Air conditioned ..	TAV	70.2

GROUP 80

Power take-off control on the gearbox ..	TAV	80.11
Rear power take-off on reduction gear with hydraulic pump	TAV	80.121
Front power take off on the engine ..	TAV	80.131
Stanley system	TAV	80.14
Rear power take off on reduction gear box	TAV	80.21
Rear power take-off control	TAV	80.22
20 ratio-reduction gear and drive shafts	TAV	80.23
Kipper	TAV	80.31
Dump assy		
(hydraulic connections)	TAV	80.313

Pistone e traverse del ribaltabile
Cassone fisso
Gancio di traino
Barre laterali antincastro
Barra antincastro - paraurti
Parafanghi e paraspruzzi
Ruota di scorta e cassetta porta attrezzi
Attrezzi e accessori

GRUPPO 90

Installazione batteria
Treccia di massa motore
Cablaggio anteriore e componenti elettrici
Cablaggio posteriore e componenti elettrici

Piston and cross members
of the tipper
Fixed body
Tow hook
Lateral guard rods
Anti-restraining bar-bumper
Wings and mudguard flaps
Spare wheel and tools box
Tools and fittings

GROUP 90

Battery installation	TAV. 90.1
Engine earth connection cable	TAV. 90.2
Front harness and electrical components	TAV. 90.3
Rear harness and electrical components	TAV. 90.4

EXTREME

**Gruppo
Group**

0

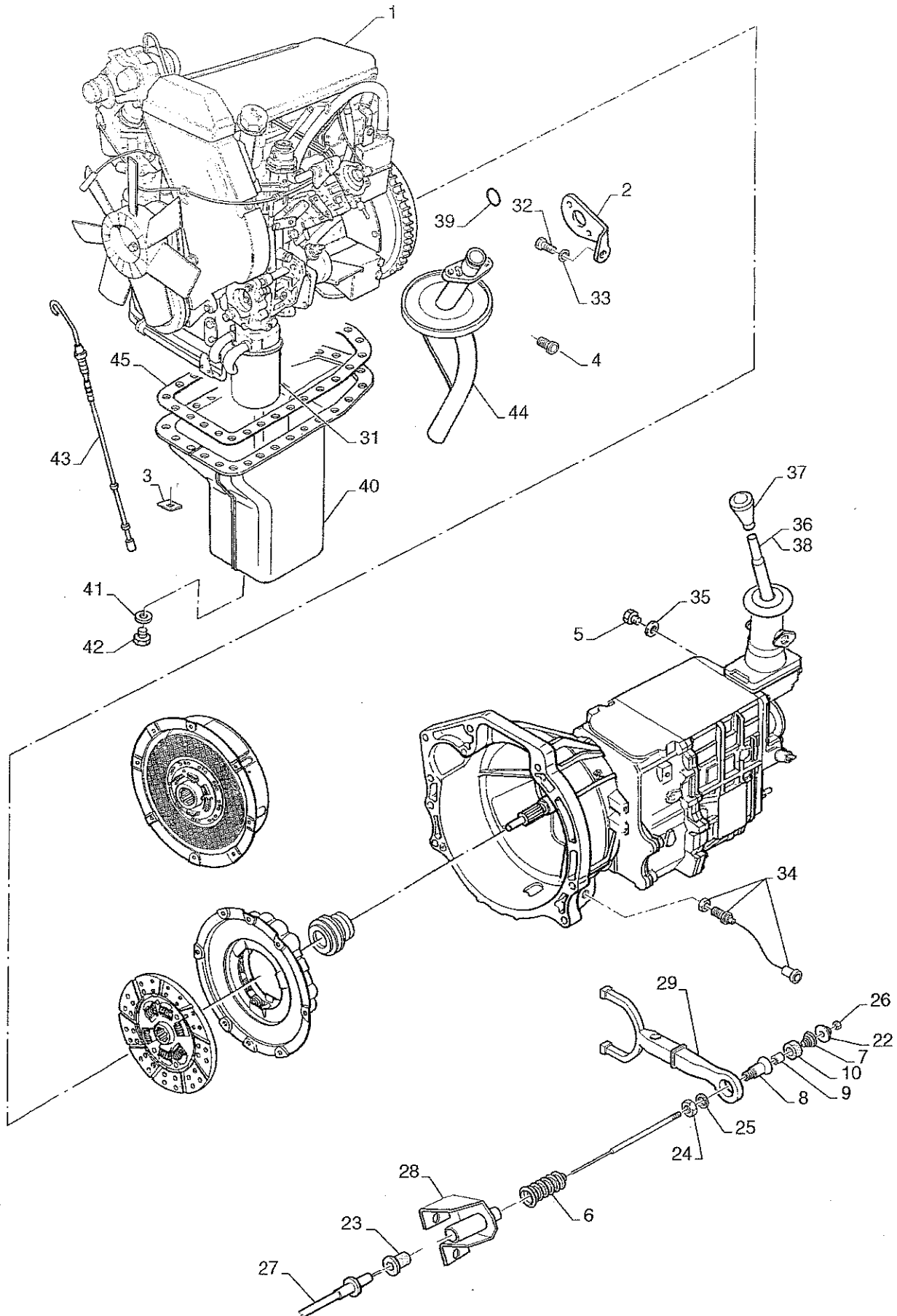

35



45



TUR
E3
20



4x4



CEE



YES
NO

BREMACHMotore-Frizione-Cambio
Engine-Friction clutch-Gearbox

TAV.

0.13

EXTREME Ed. 04 / 2002

N. Pos.	COD.	DENOMINAZIONE	Q.ty	DESCRIPTION	Da matricola Serial number
1	91H1029	Motore turbo E3 completo	1	Turbo engine	200001
2	90H1006	Staffa sostegno motorino avviamento	1	Bracket	200001
3	91H1032	Piastrina di sicurezza coppa olio	19	Washer	200001
4	10275501	Tappo conico	1	Plug	200001
5	80489	Tappo filettato	1	Plug	200001
6	90H1021	Cuffia protezione cavo frizione	1	Boot	200001
7	90h1022	Molla richiamo frizione	1	Spring	200001
8	90H1023	Perno richiamo frizione	1	Pin	200001
9	90H1024	Distanziale per richiamo frizione	1	Spacer	200001
10	90H1025	Boccola di gomma per frizione	1	Bushing	200001
21	201081	Vite M12x50 UNI 5737-65	1	Bolt	200001
22	90H1026	Puntale richiamo frizione	1	Clutch return cap	200001
23	90H1009	Gommino per frizione	1	Rubber	200001
24	202202	Dado M10x1,25 H6 UNI 5589	1	Nut	200001
25	203114	Rondella piana 10x22x2	1	Washer	200001
26	202003	Dado M6 UNI 5587-08	1	Nut	200001
27	90L5007	Cavo comando frizione	1	Clutch cable	200001
28	91H1035	Staffa di reazione al filo frizione	1	Bracket	200001
29	90L5011	Leva interna comando frizione	1	Lever	200001
30	90L5009	Supporto perno leva frizione	1	Support	200001
31	90H0100	Filtro olio motore	1	Filter	200001
32	A9014+	Vite M10x25x1,25	1	Bolt	200001
33	203004	Rondella elastica 10x20x2,3	1	Washer	200001
34	90P1608	Trasduttore contagiri	1	Revolution counter sensor	200001
35	80490	Guarnizione	1	Gasket	200001
36	91L8000	Leva marce per due / tre posti anteriori	1	Lever	200001
37	90L8001	Pomolo leva marce	1	Handle	200001
39	90H1010	O.Ring	1	O.Ring	200001
40	H7002	Coppa olio speciale	1	Mirror	200001
41	H7007	Guarnizione tappo sottocoppa	1	Gasket	200001
42	H7006	Tappo sottocoppa	1	Plug	200001
43	91H1031	Astina livello olio	1	Dipstick	200001
44	H7003	Tromba aspirazione olio	1	Sump filter	200001
45	H7005	Guarnizione sottocoppa	1	Gasket	200001

TAV.

0.21

Supporto anteriore motore
Front motor support

BREMACH

EXTREME Ed. 04 / 2002

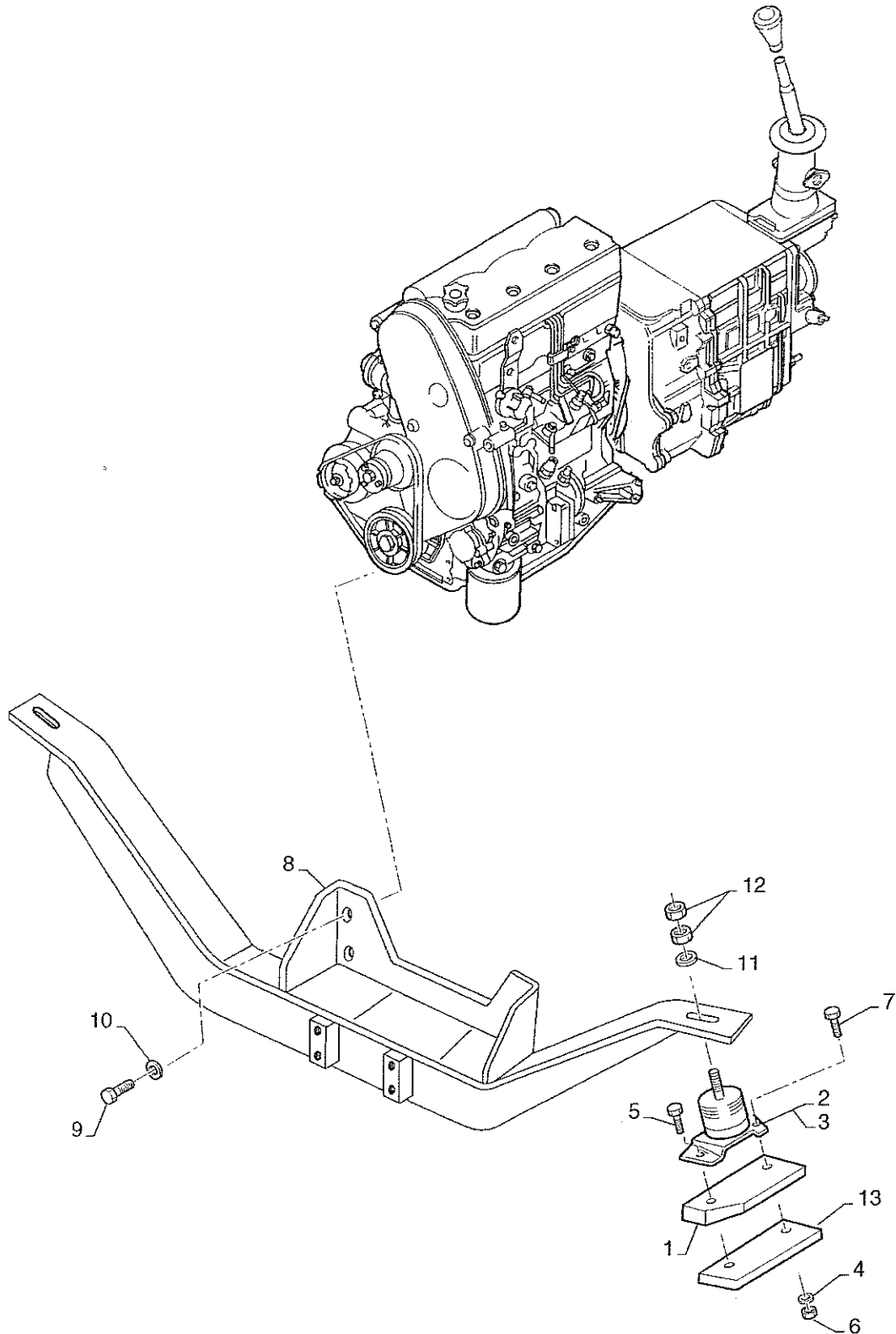

35
45



TUR
E3



20



4x4



45
45



45
45

CEE
□



45
45



45
45



YES
NO

BREMACHSupporto anteriore motore
Front motor supportTAV. **0.21**

EXTREME Ed. 04 / 2002

N. Pos.	COD.	DENOMINAZIONE	Q.ty	DESCRIPTION	Da matricola Serial number
1	90H1002	Spessore per supporto motore	2	Shim	200001
2	D8033	Supporto elastico anteriore destro motore	1	Support	200001
3	D8034	Supporto elastico anteriore sinistro motore	1	Support	200001
4	203003	Rondella elastica 8x16x1,9	4	Washer	200001
5	201024	Vite M8x35	2	Bolt	200001
6	202024	Dado M8	1	Nut	200001
7	201026	Vite M8x40	2	Bolt	200001
8	91N2005	Supporto motore anteriore	2	Support	200001
9	201082	Vite M10x1,25	4	Bolt	200001
10	203004	Rondella	4	Washer	200001
11	202304	Rondella elastica 10x20x2,3	2	Washer	200001
12	202202	Dado M10x1,25	4	Nut	200001
13	90H1056	Spessore 15mm	2	Spacer	200001

TAV.

0.22

Supporto posteriore motore

Rear motor support

BREMACH

EXTREME Ed. 04 / 2002

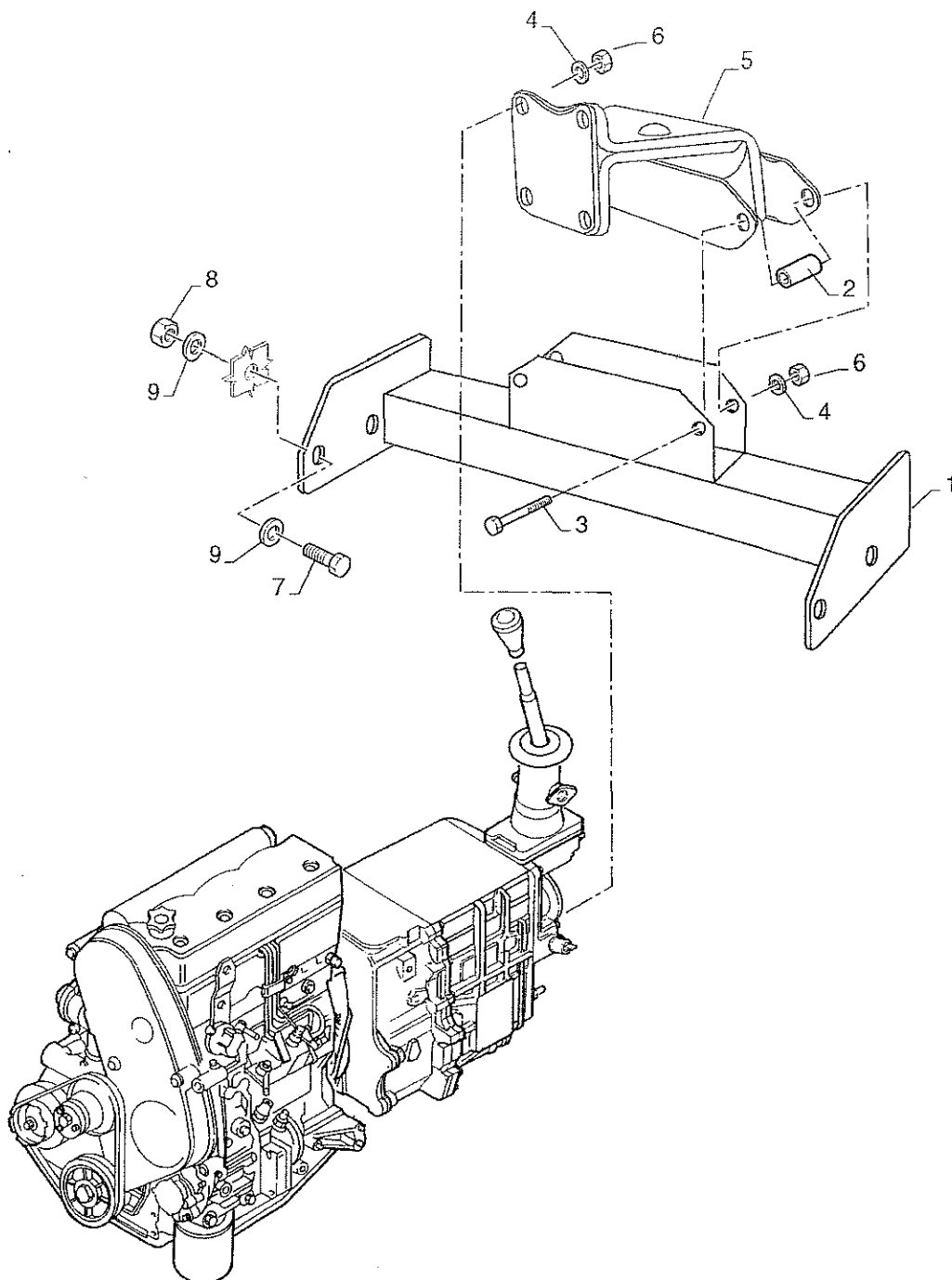

BREMACHSupporto posteriore motore
Rear motor supportTAV. **0.22**
EXTREME Ed. 04 / 2002

N. Pos.	COD.	DENOMINAZIONE	Q.ty	DESCRIPTION	Da matricola Serial number
1	91S3000	Traversa posteriore sostegno cambio	1	Gearbox supporting	200001
2	A1022	Distanziale per traversa posteriore	2	Spacer	200001
3	201031	Vite M8x70	2	Bolt	200001
4	203003	Rondella elastica 8x16x1,9	2	Washer	200001
5	90N2004	Tassellino di supporto	1	Support	200001
6	202012	Dado M6 UNI 5588-65	2	Nut	200001
7	201041	Vite M10x25 UNI 5739-65	4	Bolt	200001
8	202018	Dado M10 UNI 5588-65	4	Nut	200001
9	203004	Rondella elastica 10x20x2,3	4	Washer	200001

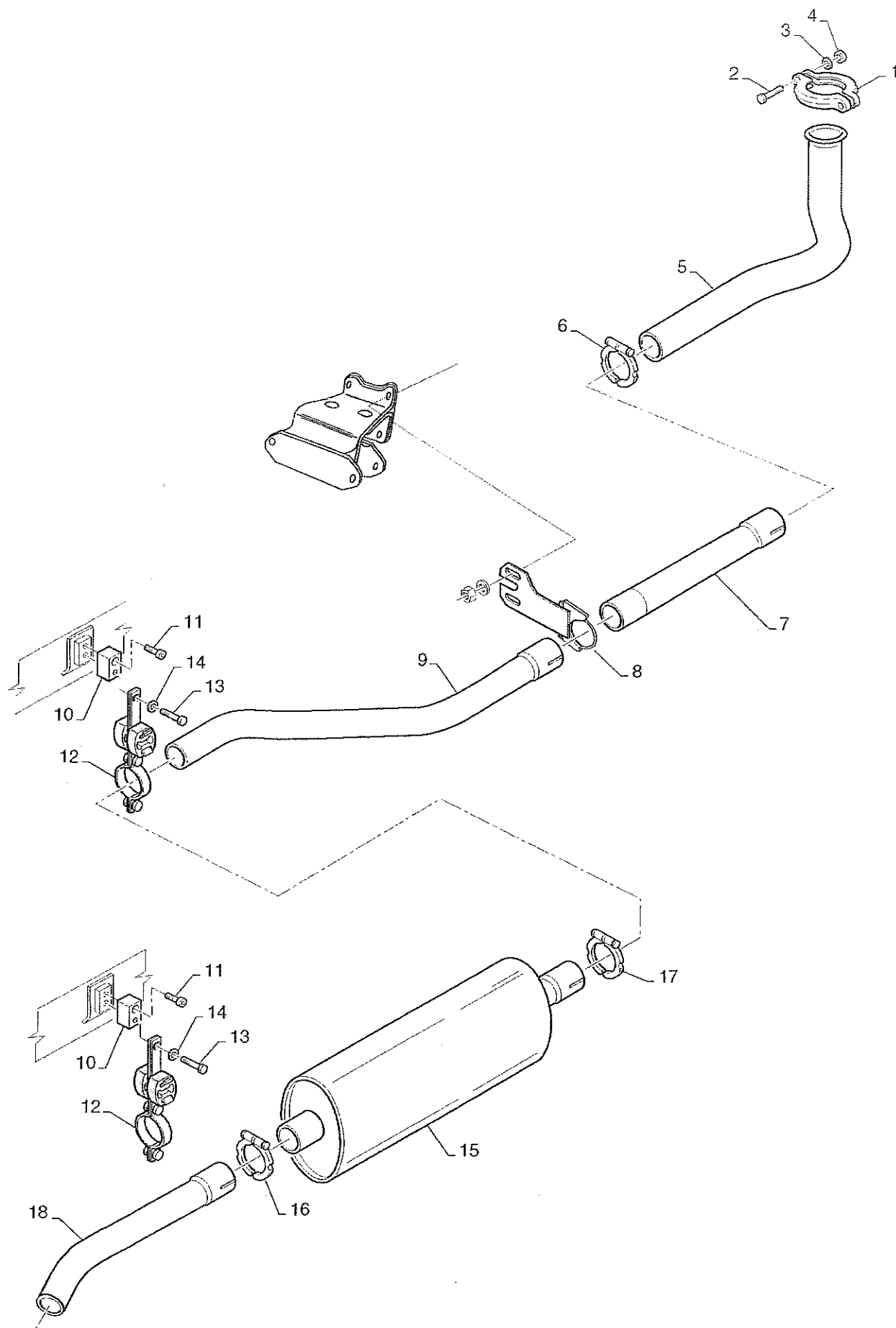

BREMACHTubazioni di scarico
Exhaust pipesTAV. **0.32**

EXTREME Ed. 04 / 2002

N. Pos.	COD.	DENOMINAZIONE	Q.ty	DESCRIPTION	Da matricola Serial number
1	90H3009	Collare collegamento tubo di scarico / collettore	2	Collar	200001
2	201031	Vite M8x70	2	Bolt	200001
3	203003	Rondella elastica 8x16x1,9	2	Washer	200001
4	202004	Dado M8 UNI 5587-68	2	Nut	200001
5	91H3018	Tubo di scarico primo tratto	1	Pipe	200001
6	90H3007	Fascetta	1	Clamp	200001
7	91H3019	Tubo collegamento tra 1 e 2 tratto	1	Pipe	200001
8	90H3037	Sostegno tubo di scarico	1	Support	200001
9	90H3035	Tubo di scarico secondo tratto	1	Pipe	200001
10	90H3027	Distanziale per sostegno elastico	2	Spacer	200001
11	201152	Vite M8x30 UNI 5931-67	2	Bolt	200001
12	90H9301	Sostegno elastico	2	Support	200001
13	201021	Vite M8x20 UNI 5739-65	2	Bolt	200001
14	203003	Rondella elastica 8x16x1,9	2	Washer	200001
15	91H3006	Marmitta	1	Silencer	200001
16	91H3002	Fascetta 56-61 marmitta	2	Clamp	200001
17	90H3008	Fascetta	1	Clamp	200001
18	90H3038	Tubo di scarico terzo tratto	1	Pipe	200001

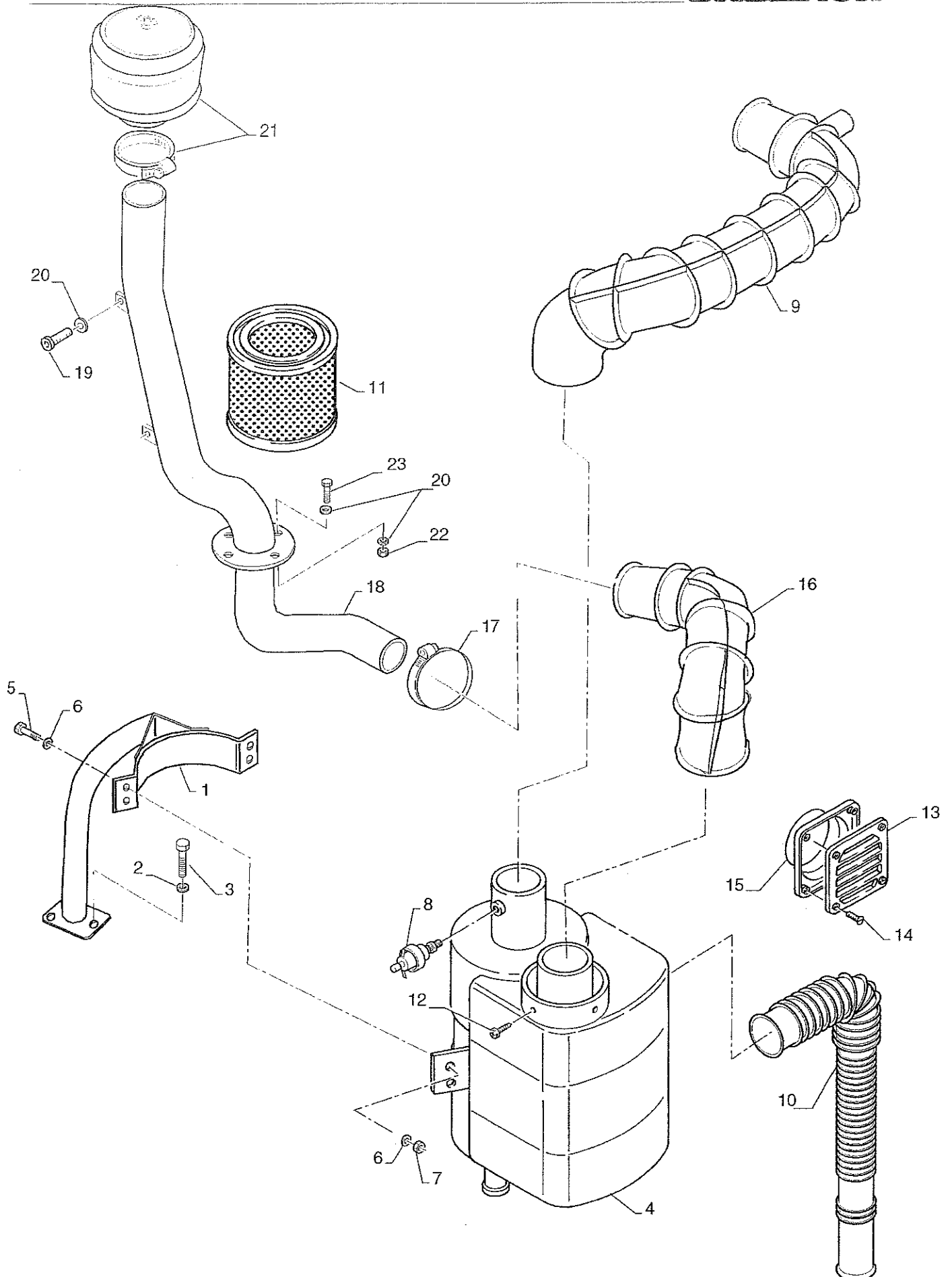

BREMACHFiltro aria
Air filterTAV. **0.42**

EXTREME Ed. 04 / 2002

N. Pos.	COD.	DENOMINAZIONE	Q.ty	DESCRIPTION	Da matricola Serial number
1	90H4023	Supporto filtro aria	1	Support	200001
2	201020	Vite M8x16 UNI 5738-65	3	Bolt	200001
3	203003	Rondella elastica 8x16x1,9	3	Washer	200001
4	91H4004	Filtro aria	1	Air filter	200001
5	201022	Vite M8x25 UNI 5739-65	4	Bolt	200001
6	203003	Rondella elastica 8x16x1,9	4	Washer	200001
7	202004	Dado M8 Uni 5587-68	4	Nut	200001
8	90H4012	Indicatore intasamento filtro aria	1	Clogging indicator	200001
9	91H4005	Tubo aria da filtro al motore	1	Pipe	200001
10	90H4014	Manicotto a soffiETTO	1	Sleeve	200001
11	90H0401	Cartuccia filtro aria	1	Filter cartridge	200001
12	204003	Vite autofil. testa a croce 4,8x16 UNI 6593-68	3	Bolt	200001
13	90H4002	Griglia aspirazione aria	1	Grid	200001
14	201401	Vite M5x10 UNI 7688 per montaggio griglia asp.	4	Bolt	200001
15	90H4003	Raccordo manicotto/griglia presa d'aria	1	Union	200001
16	90H4021	Manicotto presa d'aria filtro E3	1	Sleeve	200001
17	D8050	Fascetta	1	Clamp	200001
18	90H4022	Tubo prefiltra tropicale	1	Prefilter pipe	200001
19	201102	Vite	2	Bolt	200001
20	203002	Rondella	8	Washer	200001
21	91H4002	Prefiltro a ciclone	1	Cyclone prefilter	200001
22	202003	Dado	3	Nut	200001
23	201012	Vite	3	Bolt	200001

TAV. **0.51**

EXTREME Ed. 04 / 2002

Vaso di espansione e tubazioni

Water reservoir and tube

BREMACH

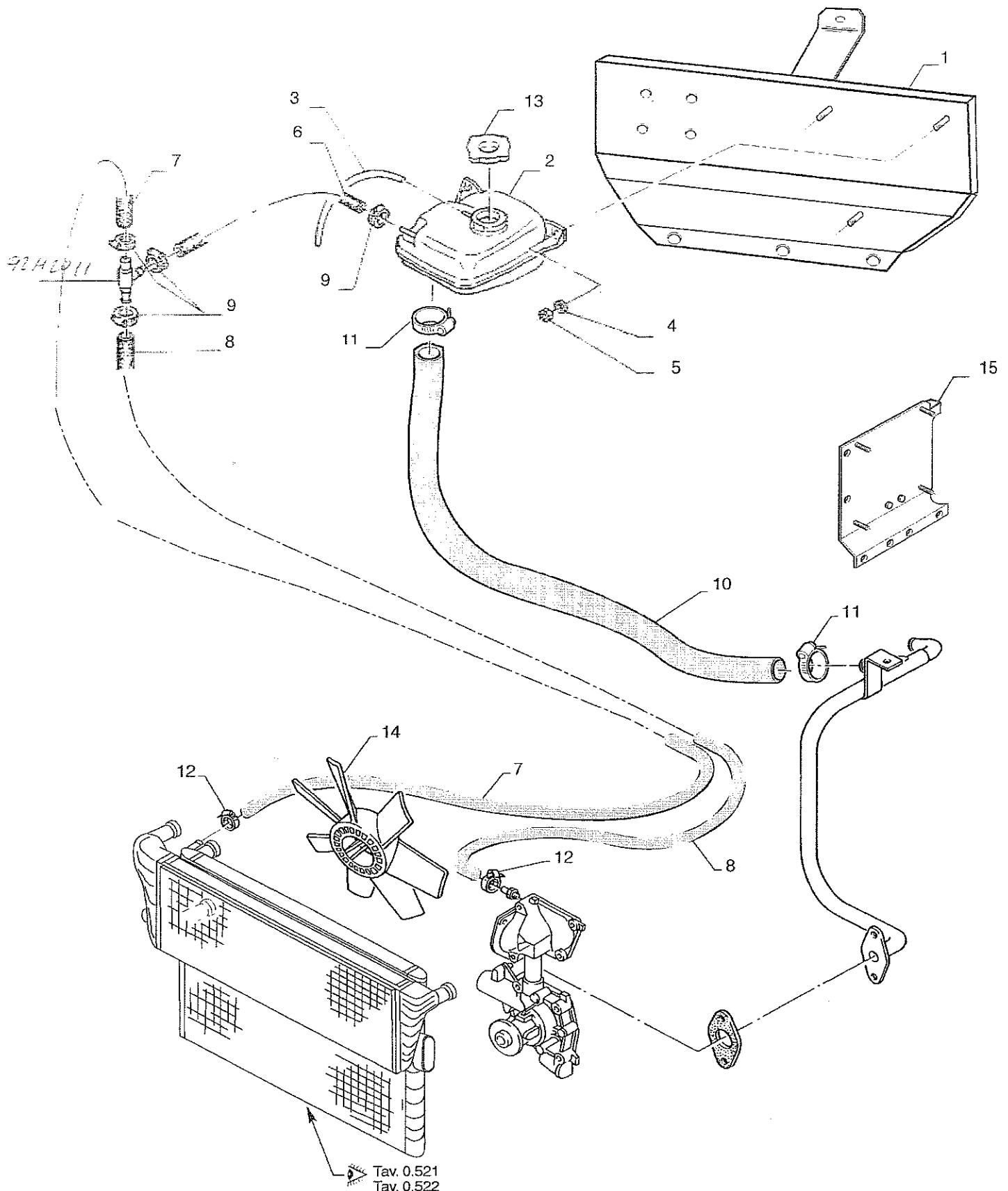

BREMACHVaso di espansione e tubazioni
Water reservoir and tubeTAV. **0.51**
EXTREME Ed. 04 / 2002

N. Pos.	COD.	DENOMINAZIONE	Q.ty	DESCRIPTION	Da matricola Serial number
1	91N9201	Mensola supporto vaschetta	1	Reservoir bracket	200001
2	92H2002	Vaschetta liquido di raffreddamento motore	1	Chamber	200001
3	92H2010	Tubo di sfiato	1	Pipe	200001
4	203002	Rondella elastica 6x18x1,6	8	Washer	200001
5	202003	Dado M6 UNI 5587-68	4	Nut	200001
6	92H2009	Tubo di sfiato vaso di espansione 6x11	1	Pipe	200001
7	92H2007	Tubo vaso di espansione radiatore	1	Pipe	200001
8	92H2008	Tubo vaso di espansione motore	1	Pipe	200001
9	83138	Fascetta	1	Clamp	200001
10	90H2003	Tubo telato da vaschetta a motore turbo	1	Pipe	200001
11	90H2013	Fascetta	2	Clamp	200001
12	D8044	Facetta S 12/93 Y	4	Clamp	200001
13	D8012	Tappo vaschetta	1	Pipe	200001
14	I-93811590	Ventola	1	Fan	200001
15	91N2008	Supporto centralina E3	1	Support	200001

TAV. **0.521**

EXTREME Ed. 04 / 2002

Radiatore
Radiator

BREMACH

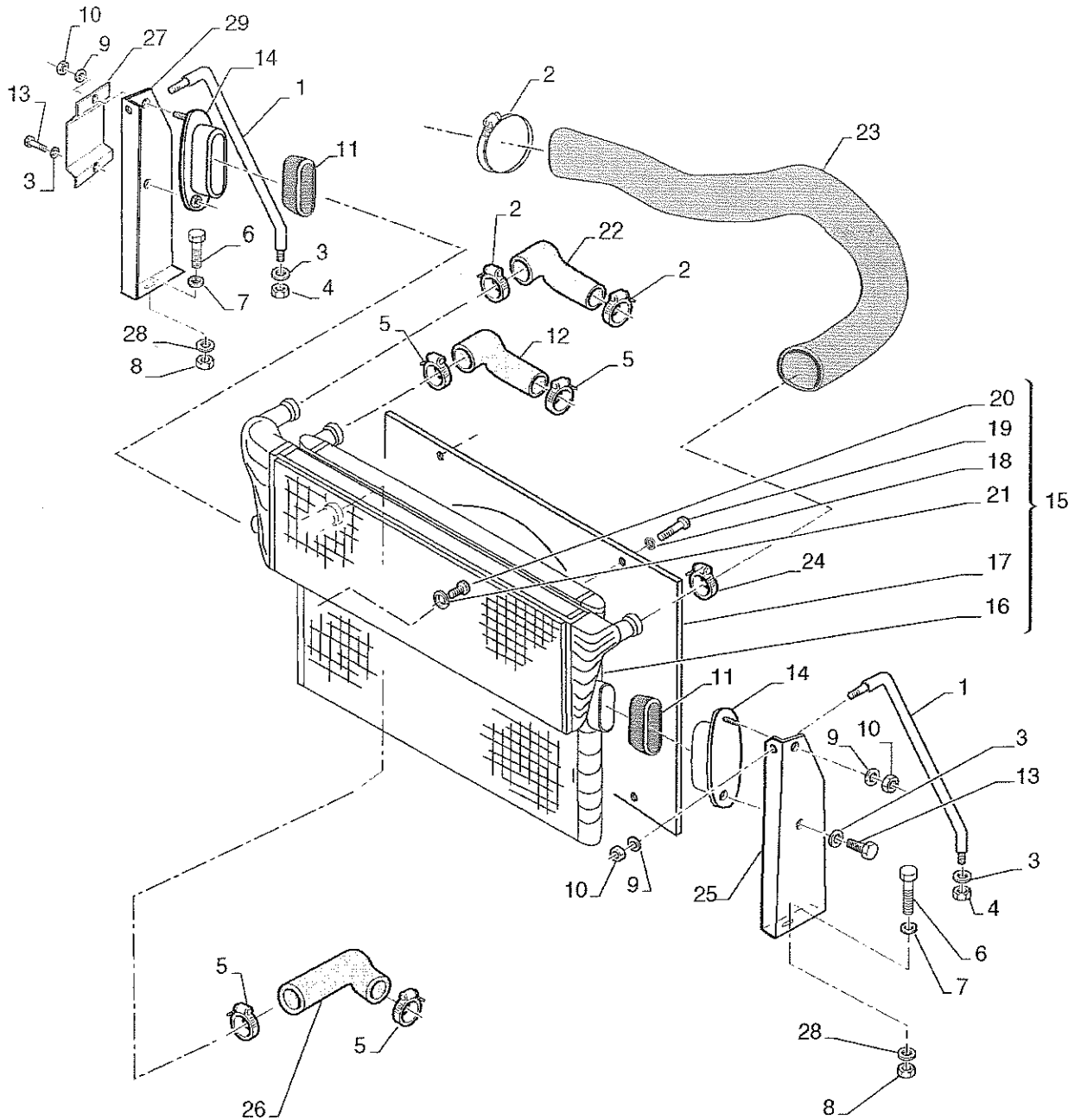

BREMACHRadiatore
RadiatorTAV. **0.521**
EXTREME Ed. 04 / 2002

N. Pos.	COD.	DENOMINAZIONE	Q.ty	DESCRIPTION	Da matricola Serial number
1	91H2012	Asta supporto radiatore	2	Rod	200001
2	91H4006	Fascetta serraggio	3	Clamp	200001
3	203003	Rondella elastica 8x16	4	Washer	200001
4	202004	Dado M8	2	Nut	200001
5	D8032	Fascetta serraggio 10/60	4	Clamp	200001
6	201041	Vite M10x25	2	Bolt	200001
7	203105	Rondella 10x30	2	Washer	200001
8	202005	Dado M10 UNI 5587-68	2	Nut	200001
9	203003	Rondella elastica 8x16	4	Washer	200001
10	202004	Dado M8	4	Nut	200001
11	94H2008	Gomma antivibrante	2	Rubber	200001
12	I-93809147	Manicotto	1	Sleeve	200001
13	201020	Vite M8x16	2	Bolt	200001
14	94H2007	Supporto radiatore	2	Support	200001
15	91H9202	Assieme radiatore	1	Complete radiartor	200001
16	91H2006	. Radiatore	1	. Radiator	200001
17	91H2007	. Convogliatore	1	. Conveyor	200001
18	202003	. Rondella	4	. Washer	200001
19	204012	. Vite autofilet.	4	. Bolt	200001
20	91H2014	. Tappo	1	. Pipe	200001
21	91H2015	. Anello di rame	1	. Ring	200001
22	I-93815303	Manicotto radiatore	1	Sleeve	200001
23	I-93822770	Manicotto turbina	1	Sleeve	200001
24	D8050	Fascetta serraggio	1	Clamp	200001
25	91H2013S	Staffa supporto radiatore	1	Bracket	200001
26	I-93811591	Manicotto	1	Sleeve	200001
27	91H2007	Staffa vaschetta liquido lavavetri	1	Bracket	200001
28	203004	Rondella 10x20	2	Washer	200001
29	91H2013D	Staffa supporto radiatore	1	Bracket	200001

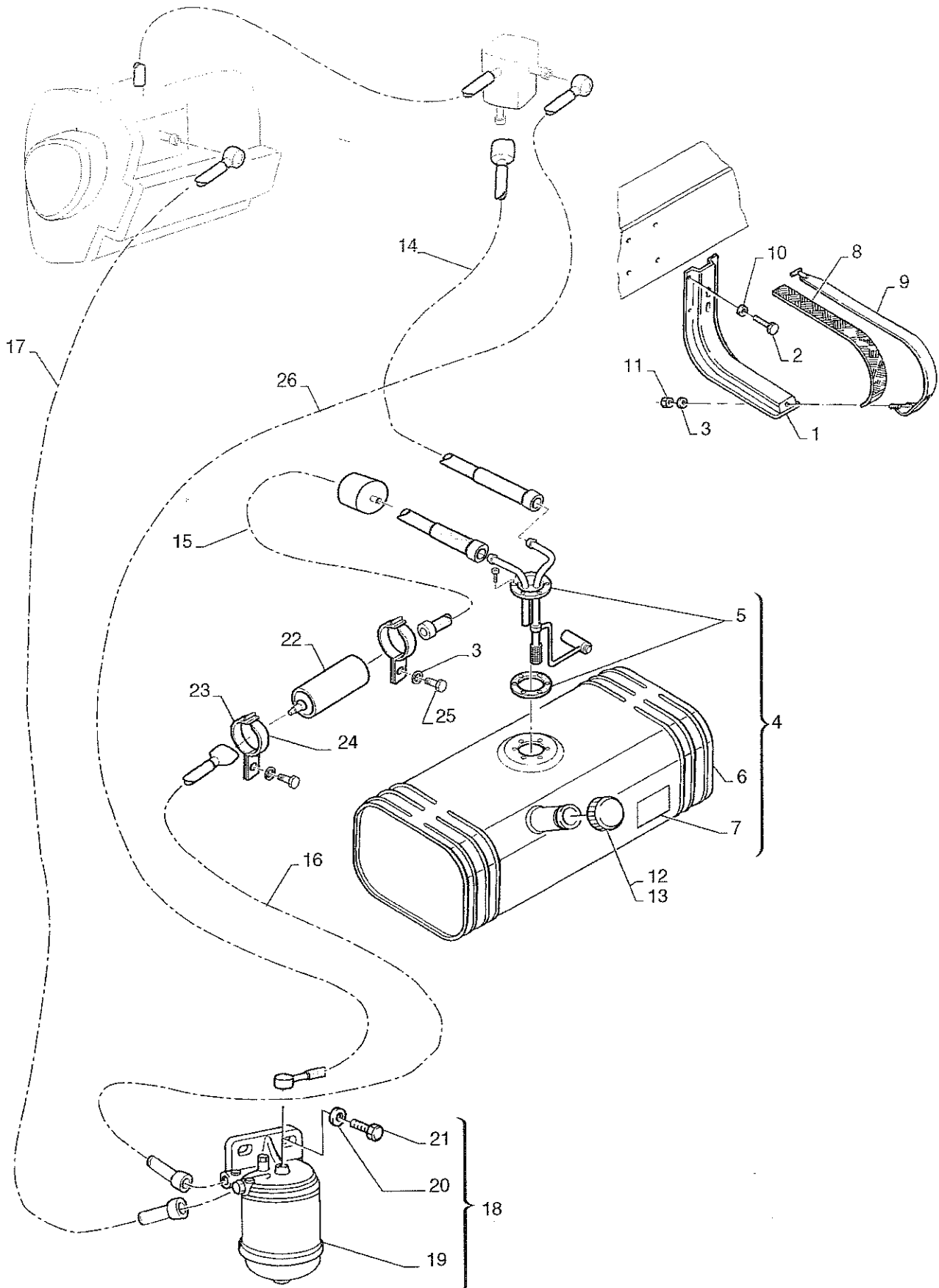

BREMACHImpianto combustibile
Fuel system

TAV.

0.61

EXTREME Ed. 04 / 2002

N. Pos.	COD.	DENOMINAZIONE	Q.ty	DESCRIPTION	Da matricola Serial number
1	90N2011	Staffa sostegno serbatoio	2	Bracket	200001
2	201020	Vite montaggio staffa M8x16 UNI 5738-63	8	Bolt	200001
3	203003	Rondella elastica 8x16x1,9	8	Washer	200001
4	91H9500	Kit serbatoio gasolio da 70 ml con targhetta	1	Tank kit	200001
5	90H5038	. Galleggiante completo	1	Complete float	200802
6	90H5028	. Serbatoio gasolio da 70 l.	1	. Gasoil tank	200001
7	90T1507	. Etichetta adesiva	1	. Adhesive label	200001
8	A1023	Guarnizione ammortiz.per fascia mont.serbatoio	2	Gasket	200001
9	90N2012	Fascetta fissaggio serbatoio	2	Clamp	200001
10	203003	Rondella elastica 8x16x1,9 per fissag. serbatoio	4	Washer	200001
11	202004	Dado M8 UNI 5587-68	2	Nut	200001
12	90H5035	Tappo serbatoio	1	Plug	200001
13	90H5015	Tappo serbatoio con chiave	1	Plug	200001
14	91H5001	Tubo recupero da ragno a serbatoio	1	Pipe	200001
15	91H5002	Tubo da serbatoio a pompa elet.	1	Pipe	200001
16	91H5005	Tubo da pompa elet. a filtro	1	Pipe	200001
17	91H5006	Tubo gasolio da filtro a pompa iniez.	1	Pipe	200001
18	91H5004	Filtro gasolio completo	1	Plate, fuel filter	200001
19	91H0501	. Cartuccia filtro gasolio	1	. Cartridge	200001
20	203110	. Rondella piana 8x24x1.7	2	. Wssher	200001
21	201023	. Vite M8x30 UNI 5739 per mont. filtro gasolio	2	. Bolt	200001
22	91H5000	Pompa elettrica per gasolio	1	Electric pump	200001
23	91H5011	Supporto femmina per pompa elet.	2	Support	200001
24	91H5010	Supporto maschio per pompa elet.	2	Support	200001
25	201021	Vite 8x20	2	Bolt	200001
26	91H5009	Tubo gasolio da ragno a filtro	1	Pipe	200001

EXTREME

**Gruppo
Group**

10

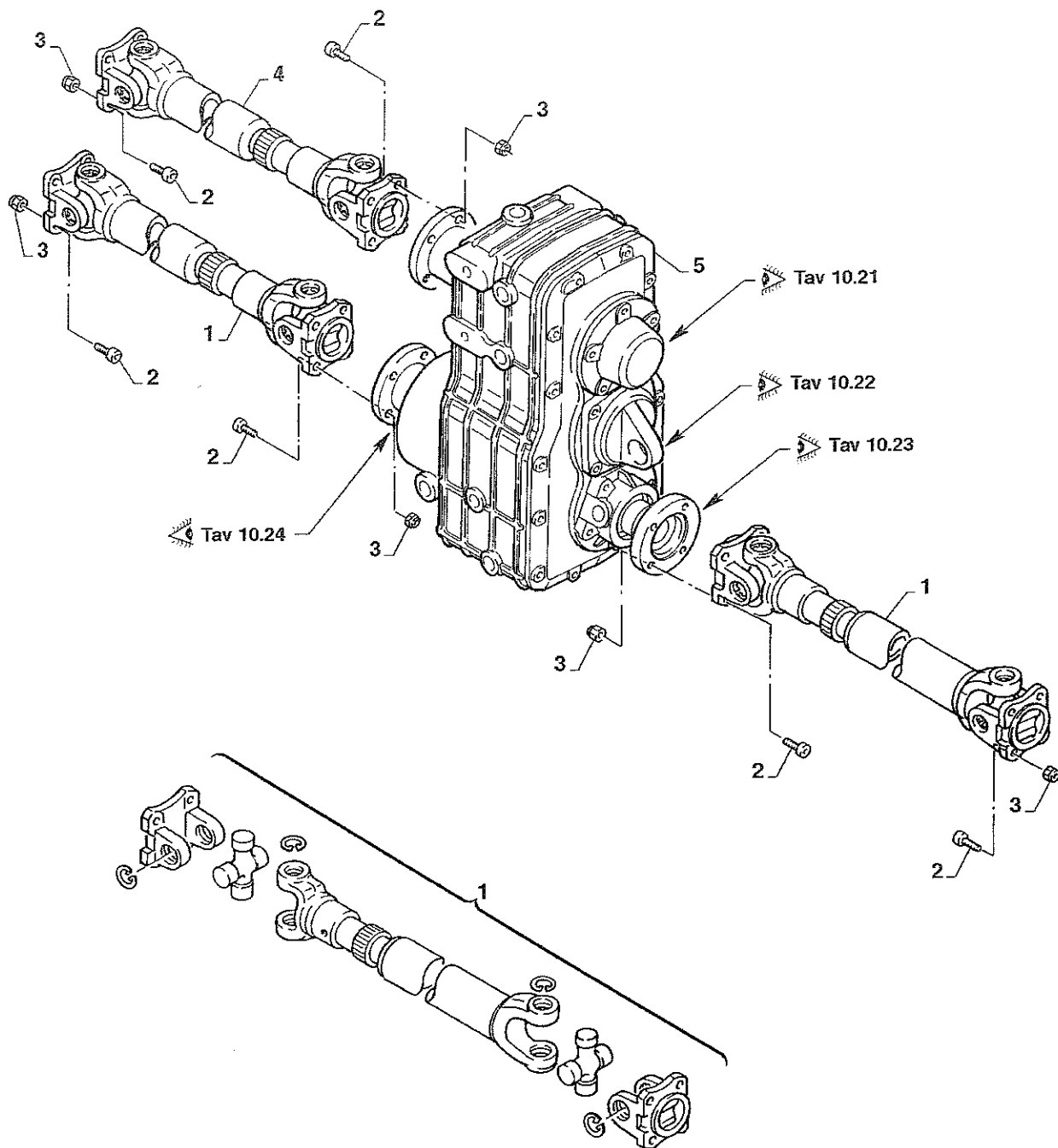

BREMACHAlberi di trasmissione passo 2600
Prop shafts weel base 2600TAV. **10.12**
EXTREME Ed. 04 / 2002

N. Pos.	COD.	DENOMINAZIONE	Q.ty	DESCRIPTION	Da matricola Serial number
1	90C1004	Assieme albero cardanico	2	Cardan shaft	200001
2	201075	Vite M12x35	32	Boft	200001
3	202104	Dado M12 autobloccante	32	Nut	200001
4	91C1005	Assieme albero cardanico	1	Cardan shaft	200001
5	RIDUT00050	Riduttore ripartitore BK20 4x4	1	20-ratio reduction gear 4x4	200001

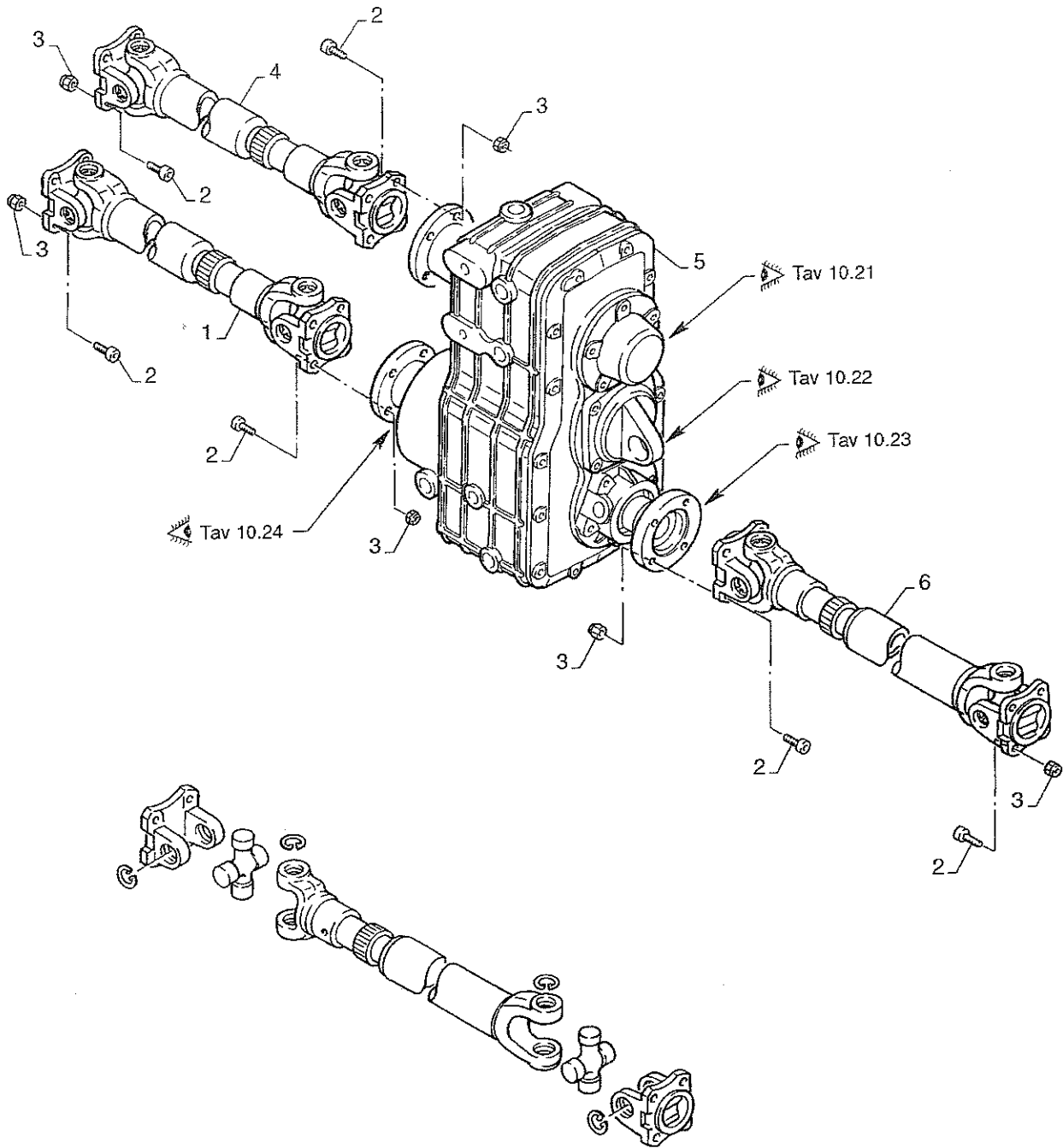

BREMACH

Alberi di trasmissione passo 3000

Prop shafts weel base 3000

TAV. **10.13**

EXTREME Ed. 04 / 2002

N. Pos.	COD.	DENOMINAZIONE	Q.ty	DESCRIPTION	Da matricola Serial number
1	90C1004	Assieme albero cardanico	1	Cardan shaft	200001
2	201075	Vite M12x35	32	Boit	200001
3	202104	Dado M12 autobloccante	32	Nut	200001
4	91C1005	Assieme albero cardanico	1	Cardan shaft	200001
5	RIDUT00050	Riduttore ripartitore BK20 4x4	1	20-ratio reduction gear 4x4	200001
6	90C1005	Assieme albero cardanico	1	Cardan shaft	200001

BREMACH

Riduttore ripartitore (albero superiore)

Reduction gearbox (up shaft)

TAV.

10.21

EXTREME Ed. 04 / 2002

N. Pos.	COD.	DENOMINAZIONE	Q.ty	DESCRIPTION	Da matricola Serial number
1	80677	Spina elastica 6x30	1	Split pin	200001
2	90R1055	Leva esterna	1	Lever	200001
3	90R1057	Albero innesto marce	1	Shaft	200001
4	A3010	O. ring	1	O. ring	200001
5	90R1013	Flangia superiore	1	Flange	200001
6	90R1024	Anello tenuta	1	Seal	200001
7	B1003	Seeger E35	1	Seeger	200001
8	201023	Vite M8x30	10	Bolt	200001
9	203003	Rondella elastica 8x16x1,9	10	Washer	200001
10	202102	Dado autobloccante M8	1	Self-locking nut	200001
11	90R1020	Rasamento ps 35x45x0,2	—	Adjusting shim	200001
12	90R1032	Rasamento ps 35x45x0,1	—	Adjusting shim	200001
13	90R1028	Cuscinetto a sfere 35x80x21 G307	1	Bearing	200001
14	90R1030	Anello elastico	2	Seal	200001
15	90R1033	Sincronizzatore	1	Synchronizing	200001
16	90R1035	Tappo in lamiera	1	Plug	200001
17	90R1045	Albero di ingresso	1	Shaft	200001
18	90R1046	Distanziale	1	Spacer	200001
19	90R1047	Nottolino	1	Pawl	200001
20	90R1048	Grano	1	Dowel	200001
21	90R1063	Forcella sincronizzatore	1	Fork	200001
22	90R1064	Ingranaggio conduttore Z=35	1	Gear	200001
23	90R1065	Ingranaggio conduttore Z=31	1	Gear	200001
24	90R1072	Distanziale	1	Spacer	200001
25	90R1079	Guarnizione	1	Gasket	200001
26	90R1002	Perno	1	Pin	200001
27	90R1010	Coperchio riduttore centrale	1	Cover	200001
28	90A2040	Flangia collegamento al cardano	1	Flange	200001
29	90R1016	Distanziale 35x65x9	2	Spacer	200001
30	90R1017	Molla	1	Spring	200001
31	90R1019	Molla di compensazione	1	Spring	200001
32	90R1023	Farfalla comando sincronizzatore	2	Butterfly nut	200001
33	90R1025	Ghiera autobloccante	1	Ring-nut	200001
34	90R1026	O. ring 4118	1	O. ring	200001
35	90R1027	Cuscinetto a sfere 35x80x21	1	Bearing	200001
36	QT1312	Anello di protezione	1	Seal	200001

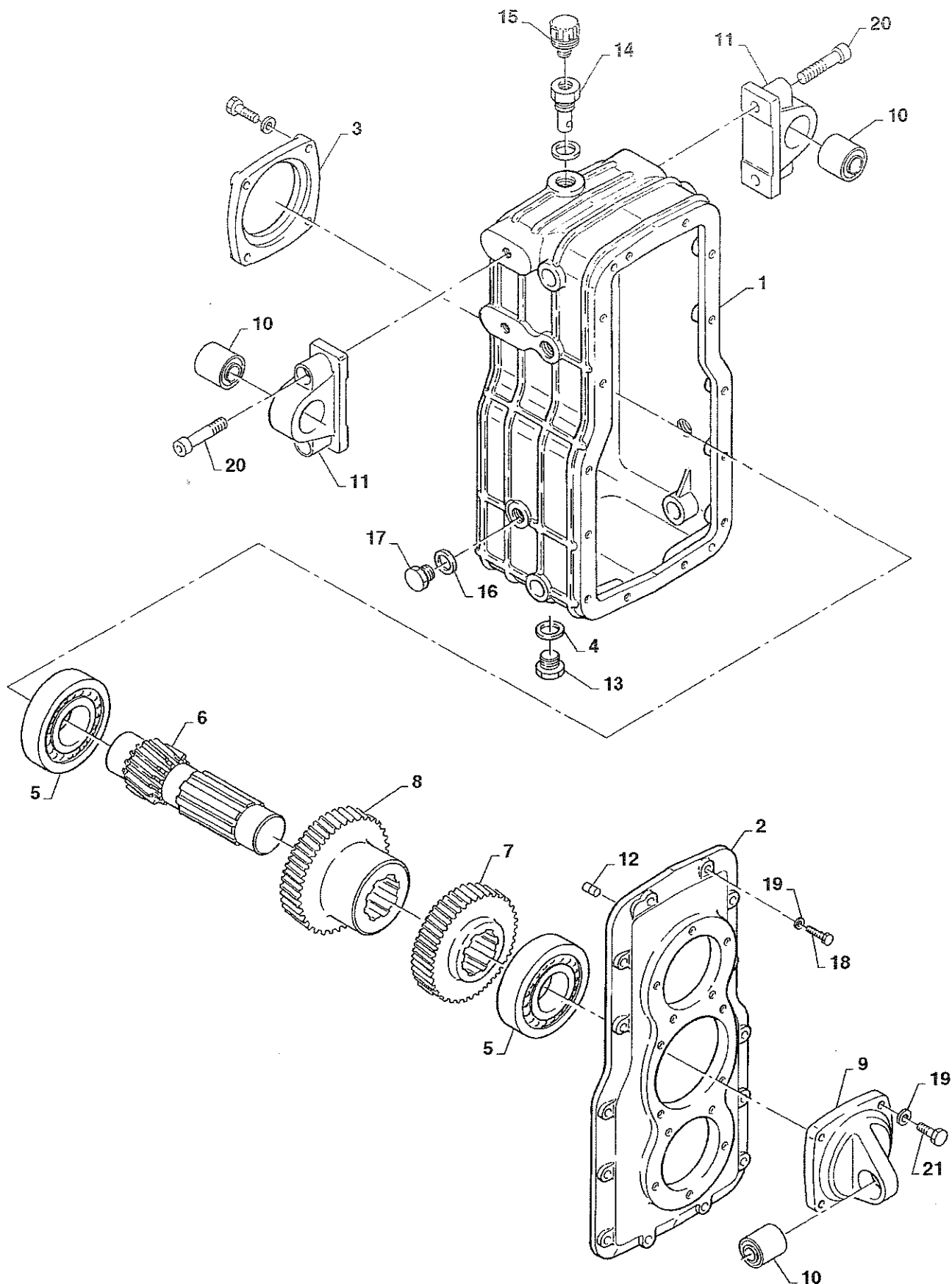

BREMACH

Riduttore ripartitore (albero intermedio)

Reduction gearbox (center shaft)

TAV. **10.22**

EXTREME Ed. 04 / 2002

N. Pos.	COD.	DENOMINAZIONE	Q.ty	DESCRIPTION	Da matricola Serial number
1	90R1004	Scatola riduttore	1	Box	200001
2	90R1005	Coperchio per scatola riduttore	1	Cover	200001
3	90R1009	Flangia	1	Flange	200001
4	90R1079	Guarnizione	2	Gasket	200001
5	90R1029	Cuscinetto a sfere 6309	2	Bearing	200001
6	90R1059	Albero intermedio	1	Shaft	200001
7	90R1060	Ingranaggio intermedio Z=34	1	Gear	200001
8	90R1061	Ingranaggio intermedio Z=38	1	Gear	200001
9	90R1006	Supporto posteriore riduttore	1	Support	200001
10	A2055	Antivibrante cilindrico	3	Damper	200001
11	90R1007	Supporto anteriore riduttore	2	Support	200001
12	A2033	Spina di riempimento	2	Pin	200001
13	A2053	Tappo scarico olio	1	Plug	200001
14	A2057	Tappo sfiato M80x2	1	Plug	200001
15	A2058	Tappo sfiato superiore	1	Plug	200001
16	A2061	Guarnizione	1	Gasket	200001
17	A2062	Tappo livello olio	1	Pipe	200001
18	201023	Vite M8x30	14	Bolt	200001
19	203003	Rondella elastica 8x16x1,9	22	Washer	200001
20	201124	Vite M12x45	4	Bolt	200001
21	201024	Vite M8x35	8	Bolt	200001

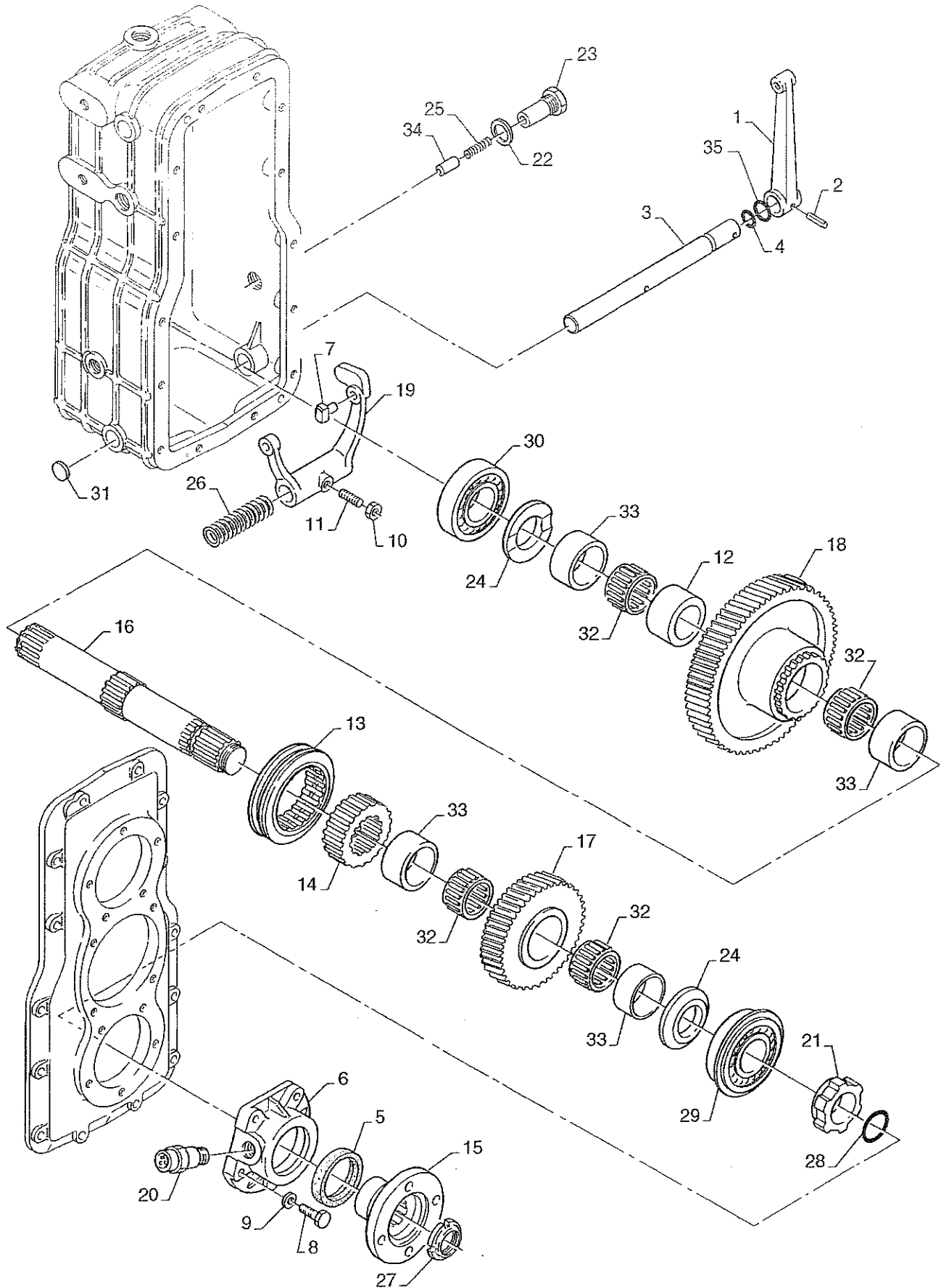

BREMACH

Riduttore ripartitore (albero inferiore)

Reduction gearbox (down shaft)

TAV.

10.23

EXTREME Ed. 04 / 2002

N. Pos.	COD.	DENOMINAZIONE	Q.ty	DESCRIPTION	Da matricola Serial number
1	90R1055	Leva esterna	1	Lever	200001
2	80677	Spina elastica	1	Elastic pin	200001
3	90R1056	Albero innesto riduttore	1	Shaft	200001
4	A3010	O. ring	1	O. ring	200001
5	90R1024	Anello di tenuta	1	Seal	200001
6	90R1077	Flangia per captatore di impulsi	1	Flange	200001
7	A2017	Farfalla per forcella d'innesto	2	Butterfly nut	200001
8	201023	Vite M8x30	5	Bolt	200001
9	203003	Rondella elastica 8x16x1,9	5	Washer	200001
10	202102	Dado autobloccante M8	1	Self-locking nut	200001
11	90R1048	Grano fermo forcella	1	Dowel	200001
12	90R1049	Distanziale per albero inferiore	1	Spacer	200001
13	90R1051	Manicotto	1	Hose	200001
14	90R1053	Mozzo	1	Hub	200001
15	90A2040	Flangia per cardano	1	Flange	200001
16	90R1066	Albero in uscita	1	Shaft	200001
17	90R1068	Ingranaggio condotto Z=36	1	Gear	200001
18	90R1069	Ingranaggio condotto Z=54	1	Gear	200001
19	90R1073	Forcella inferiore	1	Fork	200001
20	90R1075	Captatore contakilometri	1	Sensor	200001
21	90R1076	Ruota conica	1	Gear	200001
22	90R1079	Guarnizione	1	Gasket	200001
23	90R1003	Perno	1	Pin	200001
24	90R1016	Distanziale	2	Spacer	200001
25	90R1017	Molla	1	Spring	200001
26	90R1018	Molla leva innesto	1	Spring	200001
27	90R1025	Ghiera autobloccante	1	Ring-nut	200001
28	90R1026	O. ring	1	O. ring	200001
29	90R1027	Cuscinetto 35x80x21 6307	1	Bearing	200001
30	90R1028	Cuscinetto 35x80x21 6307	1	Bearing	200001
31	90R1035	Tappo in lamiera	1	Plug	200001
32	90R1039	Gabbia a rulli 42x50x20	4	Needle bearing bush	200001
33	90R1040	Anello interno	4	Seal	200001
34	90R1047	Nottolino	1	Pawl	200001
35	QT1312	Anello di protezione	1	Seal	200001

BREMACHRiduttore ripartitore centrale (innesto avantreno)
Reduction gearbox (forecarriage coupling)TAV. **10.24**

EXTREME Ed. 04 / 2002

N. Pos.	COD.	DENOMINAZIONE	Q.ty	DESCRIPTION	Da matricola Serial number
1	90R1002	Perno	1	Pin	200001
2	90R1011	Scatola trazione anteriore	1	Box	200001
3	90R1017	Molla	1	Spring	200001
4	90R1019	Molla di compensazione	1	Spring	200001
5	90R1020	Rasamento tipo ps 35x45x0,2	1	Adjusting shim	200001
6	90R1025	Ghiera autobloccante	1	Ring-nut	200001
7	90R1026	O. Ring	2	O. Ring	200001
8	90R1031	Anello seeger UNI 7435	1	Seal	200001
9	90R1035	Tappo in lamiera	1	Plug	200001
10	90R1037	Gabbia a rullini 15x20x13	1	Needle bearing bush	200001
11	90R1047	Nottolino	1	Pawl	200001
12	90R1048	Grano fermo forcella	1	Dowel	200001
13	90R1050	Mozzo d'innesto	1	Hub	200001
14	90R1052	Manicotto scorrevole	1	Hose	200001
15	90R1054	Forcella per innesto	1	Fork	200001
16	90A2040	Flangia per cardano	1	Flange	200001
17	90R1079	Guarnizione	1	Gasket	200001
18	90R1058	Albero innesto trazione	1	Shaft	200001
19	80677	Spina elastica	1	Elastic pin	200001
20	90R1055	Leva esterna	1	Lever	200001
21	A3010	O. ring	1	O. ring	200001
22	90R1012	Flangia	1	Flange	200001
23	83075	Seeger Din 472 62I	1	Seeger	200001
24	90R1024	Anello di tenuta	1	Seal	200001
25	90R1034	Seeger E50	1	Seeger	200001
26	90R1044	Cuscinetto a sfera 6007	1	Bearing	200001
27	90R1067	Albero in uscita	1	Shaft	200001
28	A2017	Farfalla per forcella d'innesto	1	Butterfly nut	200001
29	B1003	Seeger	2	Seeger	200001
30	201022	Vite M8x30	5	Bolt	200001
31	203003	Rondella elastica 8x16x1,9	10	Washer	200001
32	201023	Vite M8x30	3	Bolt	200001
33	202102	Dado autobloccante	1	Self-locking nut	200001
34	201027	Vite M8x45	2	Bolt	200001
35	QT1312	Anello di protezione	1	Seal	200001

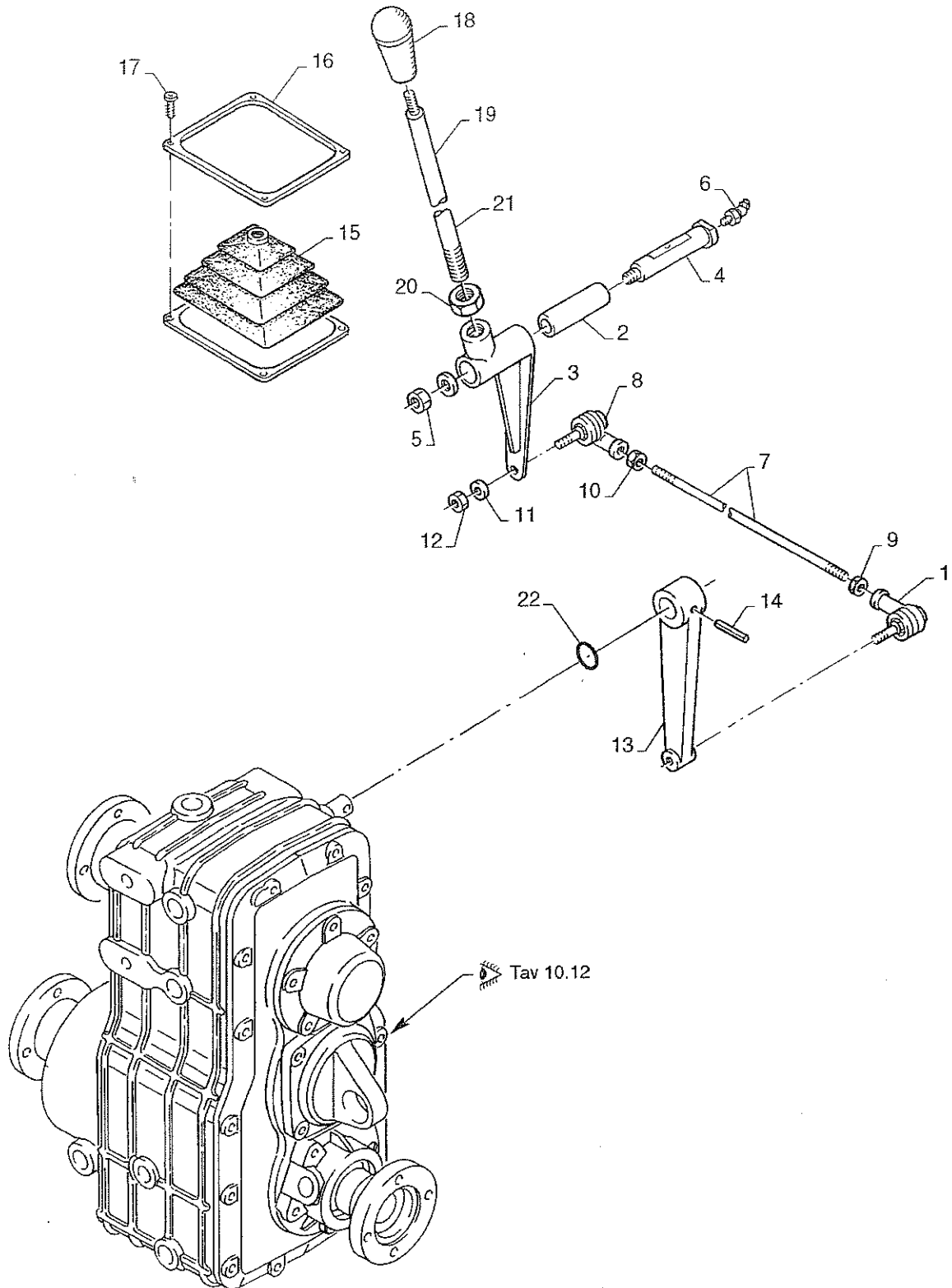

BREMACHComando innesto ripartitore/riduttore (R=1:1,3)
Control of reduction gear box coupling (R=1:1,3)TAV. **10.25**

EXTREME Ed. 04 / 2002

N. Pos.	COD.	DENOMINAZIONE	Q.ty	DESCRIPTION	Da matricola Serial number
1	83573	Snodo destro per colleg. asta rinvio	1	Joint RH	200001
2	80935	Boccola 16x21x60	1	Bushing	200001
3	90L3002	Leva innesto ridotta	1	Lever	200001
4	80943	Spinotto leva d'innesto	1	Connector	200001
5	202103	Dado M10 autobloccante	1	Nut	200001
6	D4032	Ingrassatore a L	1	Fitting	200001
7	D1003	Asta rinvio comando riduttore	1	Rod	200001
8	83574	Snodo sinistro per colleg. asta rinvio	1	Joint LH	200001
9	83372	Dado M8 sx per colleg. asta rinvio	1	Nut	200001
10	202012	Dado M8 UNI 5588-65	1	Nut	200001
11	203003	Rondella elastica 8x16x1,9	1	Washer	200001
12	202004	Dado M8 UNI 5587-68	1	Nut	200001
13	90R1055	Leva innesto al riduttore	1	Lever	200001
14	80677	Spina elastica 6x30 UNI 6873	1	Elastic pin	200001
15	83556	Cuffia leva innesto riduttore 1:1,3	1	Boot	200001
16	83557	Cornice coprifilo montaggio cuffia	1	Cornice	200001
17	204001	Vite autofil. testa a croce 3,5x13	4	Bolt	200001
18	83858	Pomello leva innesto ripartitore	1	Knob	200001
19	D1001	Leva innesto ripartitore riduttore	1	Lever	200001
20	202007	Dado bloccaggio leva	1	Nut	200001
21	90L3013	Leva comando innesto riduttore 1:1,3 (3 posto cab.)	1	Lever	200001
22	QT1312	Anello di protezione	1	Seal	200001

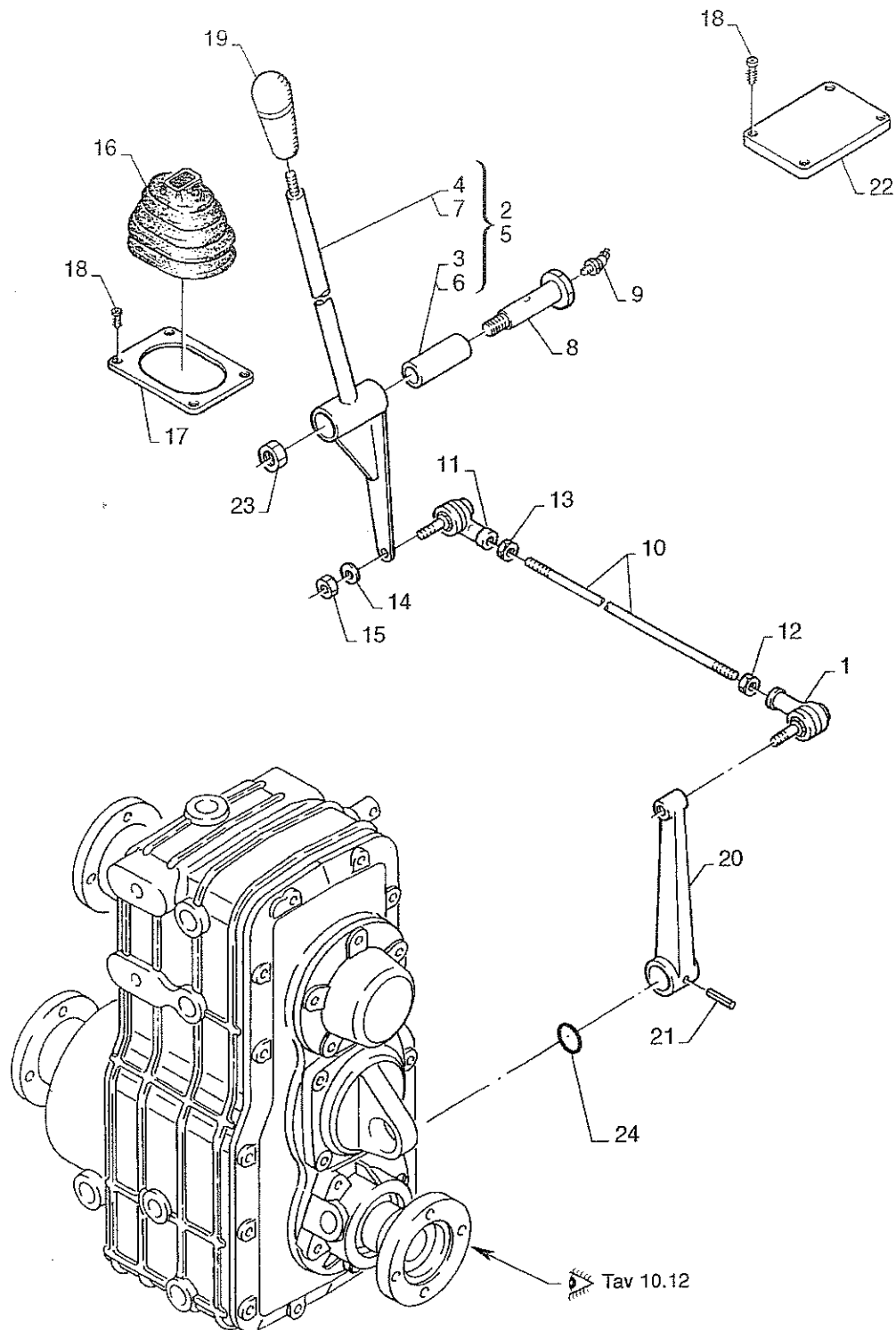

BREMACHComando innesto ridotta (R=1:3)
Controls of reducer speed coupling (R=1:3)TAV. **10.26**

EXTREME Ed. 04 / 2002

N. Pos.	COD.	DENOMINAZIONE	Q.ty	DESCRIPTION	Da matricola Serial number
1	83573	Snodo destro per colleg. asta rinvio	1	Joint RH	200001
2	90L3015	Assieme leva innesto 2 posti	1	Arm Assy	200001
3	80934	. Boccola 16x21x60	1	. Bushing	200001
4	90L3003	. Leva innesto	1	. Lever	200001
5	90L3018	Assieme leva innesto 3 posti	1	Arm Assy	200001
6	80934	. Boccola 16x21x60	1	. Bushing	200001
7	90L3017	. Leva innesto	1	. Lever	200001
8	90L3007	Perno leva innesto	1	Pin	200001
9	D4032	Ingrassatore AL	1	Fitting	200001
10	90L3009	Asta di rinvio comando di innesto ridotta	1	Rod	200001
11	83574	Snodo sx IKO per colleg. asta di rinvio comando	1	Joint LH	200001
12	83372	Dado M8 sx per colleg. asta di rinvio comando	1	Nut	200001
13	202012	Dado M8 UNI 5598-65	1	Nut	200001
14	203003	Rondella elastica 8x16x1,9 per colleg. asta rinvio	1	Washer	200001
15	202004	Dado M8 UNI 5587-68 per colleg. asta rinvio	1	Nut	200001
16	90L3004	Cuffia leva innesto	1	Boot	200001
17	90L3005	Cornice montaggio cuffia	1	Cornice	200001
18	204001	Vite autofilettante	1	Bolt	200001
19	90L3011	Pomello leva innesto ridotta (1:3)	1	Knob	200001
20	90R1055	Leva innesto al riduttore	1	Lever	200001
21	80677	Spina elastica 6x3 UNI 6873	1	Elastic pin	200001
22	90P1012	Coperchio	1	Cover	200001
23	202006	Dado M12	1	Nut	200001
24	QT1312	Anello di protezione	1	Seal	200001

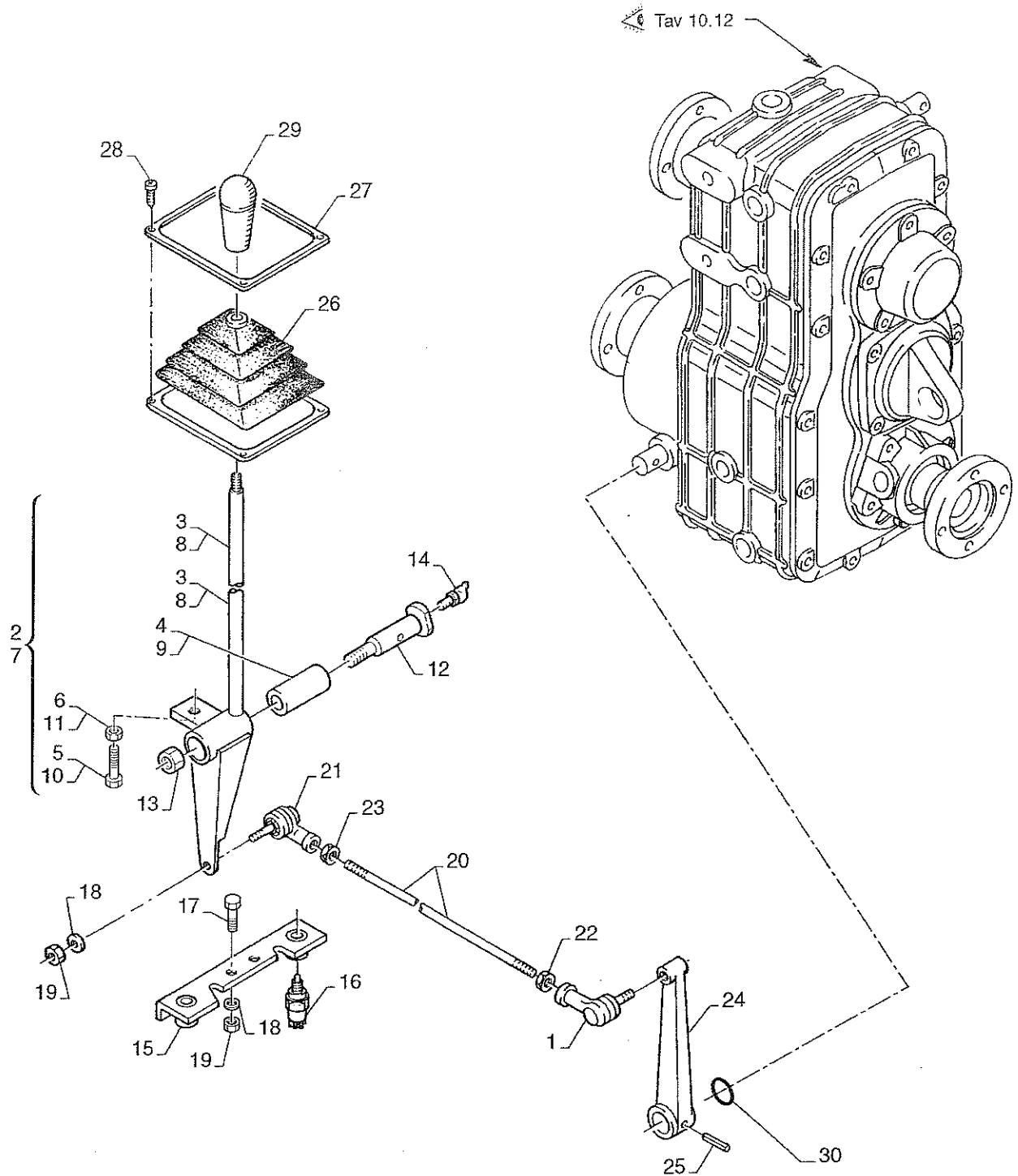

BREMACHComando innesto avantreno
Forecarriage coupling controlTAV. **10.27**

EXTREME Ed. 04 / 2002

N. Pos.	COD.	DENOMINAZIONE	Q.ty	DESCRIPTION	Da matricola Serial number
1	83573	Snodo destro	1	Joint RH	200001
2	90L9100	Assieme completo leva innesto 2 posti	1	Arm Assy	200001
3	90L1002	. Leva innesto	1	. Lever	200001
4	80934	. Boccola 16x22x50	1	. Bushing	200001
5	201601	. Vite TQ M 6x25	1	. Bolt	200001
6	202003	. Dado M6	1	. Nut	200001
7	90L9103	Assieme completo leva innesto 3 posti	1	Arm Assy	200001
8	90L1003	. Leva innesto (3 posto in cabina)	1	. Lever	200001
9	80934	. Boccola 16x22x50	1	. Bushing	200001
10	201601	. Vite TQ M 6x25	1	. Bolt	200001
11	202003	. Dado M6	1	. Nut	200001
12	90L3007	Perno leva di innesto	1	Pin	200001
13	202104	Dado M12 autobloccante	1	Self-locking nut	200001
14	D4032	Ingrassatore	1	Fitting	200001
15	D2004	Supporto microinterruttore	1	Support	200001
16	F3011	Microinterruttore	1	Microswitch	200001
17	201021	Vite M 8x20	2	Bolt	200001
18	202003	Rondella elastica 8x16x1,9	3	Washer	200001
19	202004	Dado M8	3	Nut	200001
20	D2003	Asta rinvio comando innesto	1	Rod	200001
21	83574	Snodo sinistro per colleg. asta rinvio	1	Joint LH	200001
22	83372	Dado M8 sinistro per colleg. asta rinvio	1	Nut	200001
23	202012	Dado M8 UNI 5588-65 per colleg. asta rinvio	1	Nut	200001
24	90R1055	Leva innesto al riduttore	1	Lever	200001
25	80677	Spina elastica 6x30 UNI 6873	1	Elastic pin	200001
26	83556	Cuffia leva innesto avantreno	1	Boot	200001
27	83557	Cornice coprifilo montaggio cuffia	1	Cornice	200001
28	204001	Vite autofil. testa a croce 3,5x13 UNI 6954	1	Bolt	200001
29	83858	Pomello leva innesto avantreno	1	Knob	200001
30	QT1312	Anello di protezione	1	Seal	200001

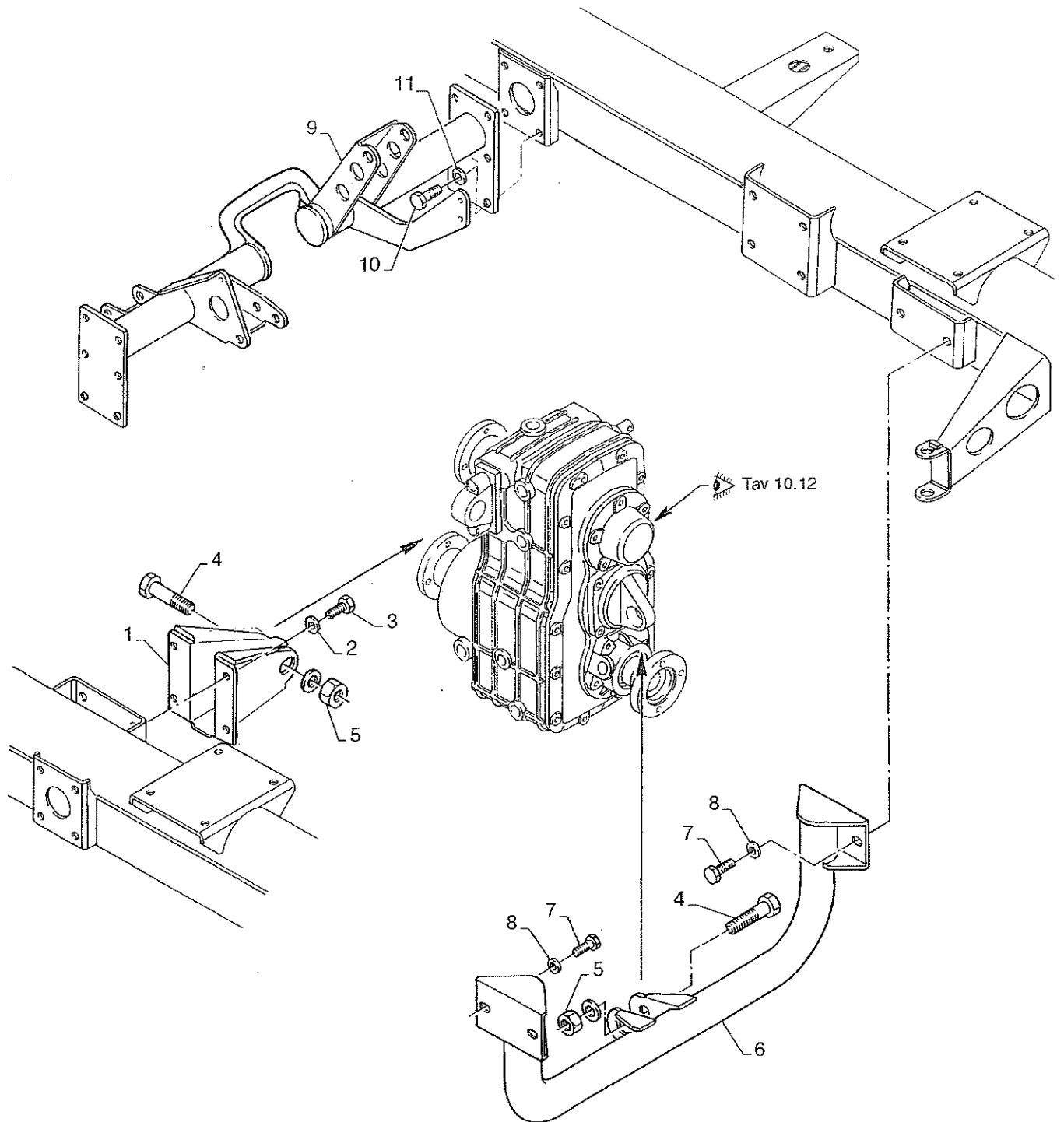

BREMACHSupporti riduttore
Reduction gear box supportsTAV. **10.283**
EXTREME Ed. 04 / 2002

N. Pos.	COD.	DENOMINAZIONE	Q.ty	DESCRIPTION	Da matricola Serial number
1	90N2001	Sostegno anteriore riduttore	2	Bearing support	200001
2	203004	Rondella elastica 10x20x2,3	8	Washer	200001
3	201041	Vite M10x25	8	Bolt	200001
4	201060	Vite M16x65	3	Bolt	200001
5	202008	Dado M16	3	Nut	200001
6	90N2005	Supporto posteriore	1	Support	200001
7	201047	Vite M10x65	4	Bolt	200001
8	203004	Rondella elastica 10x20x2,3	4	Washer	200001
9	90S3001	Traversa completa con attacchi leve comando	1	Cross member	200001
10	201020	Vite M8x16	8	Bolt	200001
11	203003	Rondella elastica 8x16x1,9	8	Washer	200001

TAV. 10.311

EXTREME Ed. 04 / 2002

Assale posteriore
Rear axle

BREMACH

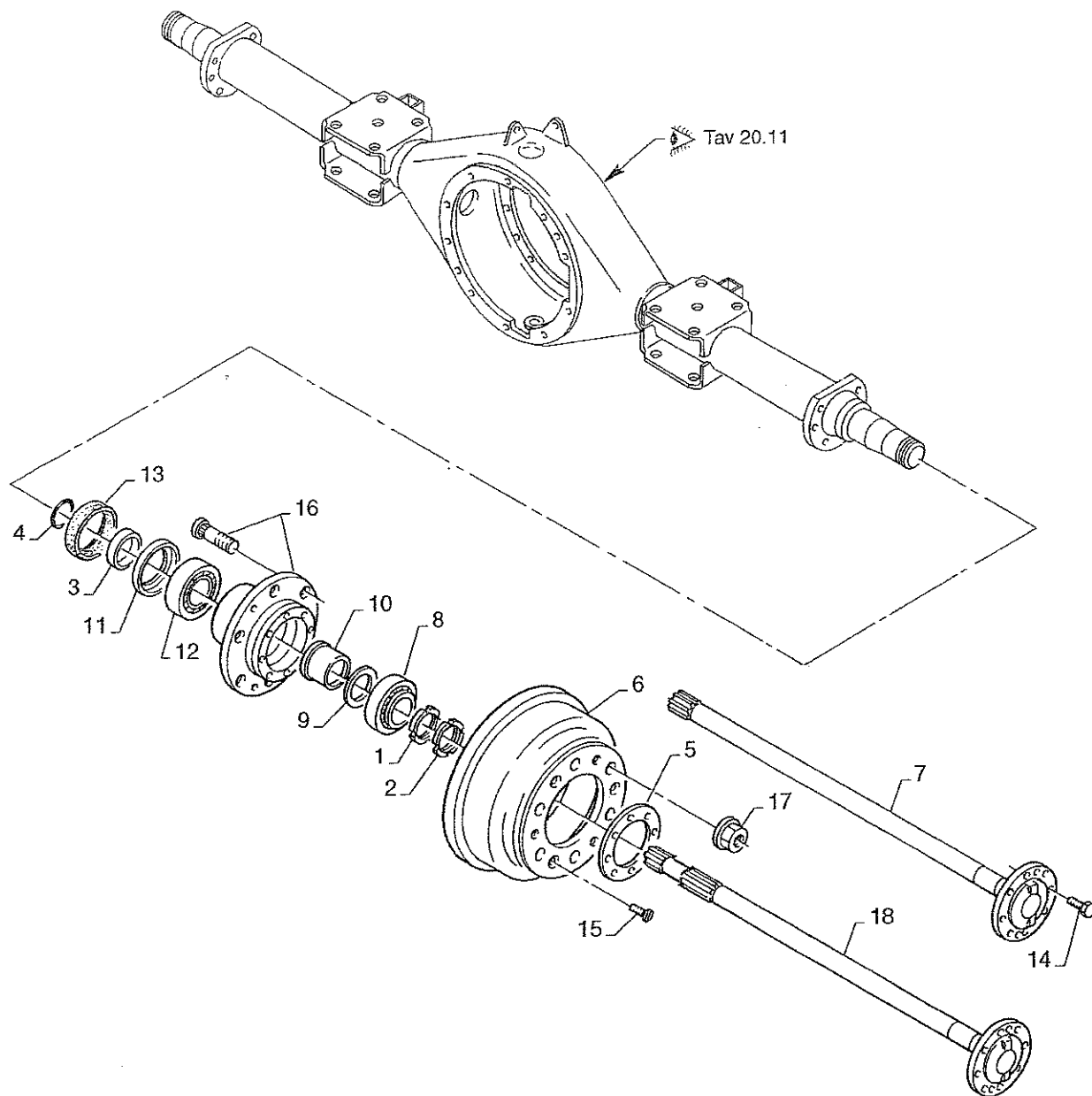

BREMACHAssale posteriore
Rear axleTAV. **10.311**
EXTREME Ed. 04 / 2002

N. Pos.	COD.	DENOMINAZIONE	Q.ty	DESCRIPTION	Da matricola Serial number
1	81041DX	Ghiera scanalata destra	2	Ring nut RH	200001
2	81041SX	Ghiera scanalata sinistra	2	Ring nut LH	200001
3	83691	Anello distanziale	2	Seal	200001
4	83692	Anello di tenuta (O.RING 3200)	2	Seal	200001
5	90A4003	Guarnizione mozzo	2	Gasket	200001
6	90A4004	Tamburo freni	2	Drum brake	200001
7	90A4012	Semiassse post dentatura corta	1	Half shaft	200001
8	81036	Cuscinetto 30209	2	Bearing	200001
9	81052	Rasamento	2	Adjusting shim	200001
10	81043	Distanziale	2	Spacer	200001
11	81044	Disco protezione mozzo	2	Disc	200001
12	81053	Cuscinetto 30210	2	Bearing	200001
13	81042	MIM 65x90x10 tipo BSL 1366	2	MIM 65x90x10 type BSL 1366	200001
14	A9014	Vite M 10x25x1	16	Bolt	200001
15	201210	Vite SPE M8x20	6	Bolt	200001
16	90A9409	Mozzo posteriore completo	2	Hub	200001
17	90C5004	Dado	12	Nut	200001
18	90A4013	Semiassse post dentatura lunga	1	Half shaft	200001

BREMACHAssale posteriore
Rear axleTAV. **10.312**

EXTREME Ed. 04 / 2002

N. Pos.	COD.	DENOMINAZIONE	Q.ty	DESCRIPTION	Da matricola Serial number
1	81041DX	Ghiera scanalata destra	2	Ring nut RH	200001
2	81041SX	Ghiera scanalata sinistra	2	Ring nut LH	200001
3	83691	Anello distanziale	2	Seal	200001
4	83692	Anello di tenuta (O.RING 3200)	2	Seal	200001
5	90A4003	Guarnizione mozzo	2	Gasket	200001
6	90A4004	Tamburo freni	2	Drum brake	200001
7	90A4012	Semiassse post dentatura corta ø 30	2	Half shaft	200001
8	81036	Cuscinetto 30209	2	Bearing	200001
9	81052	Rasamento	2	Adjusting shim	200001
10	81043	Distanziale	2	Spacer	200001
11	81044	Disco protezione mozzo	2	Disc	200001
12	81053	Cuscinetto 30210	2	Bearing	200001
13	81042	MIM 65x90x10 tipo BSL 1366	2	MIM 65x90x10 type BSL 1366	200001
14	A9014	Vite M 10x25x1	16	Bolt	200001
15	201210	Vite SPE M8x20	6	Bolt	200001
16	90A9409	Mozzo posteriore completo	2	Hub	200001
17	90C5004	Dado	12	Nut	200001
18	90A4013	Semiassse posteriore dentatura lunga	1	Half shaft	200001

TAV. 10.322

EXTREME Ed. 04 / 2002

Assale anteriore

Front axle

BREMACH

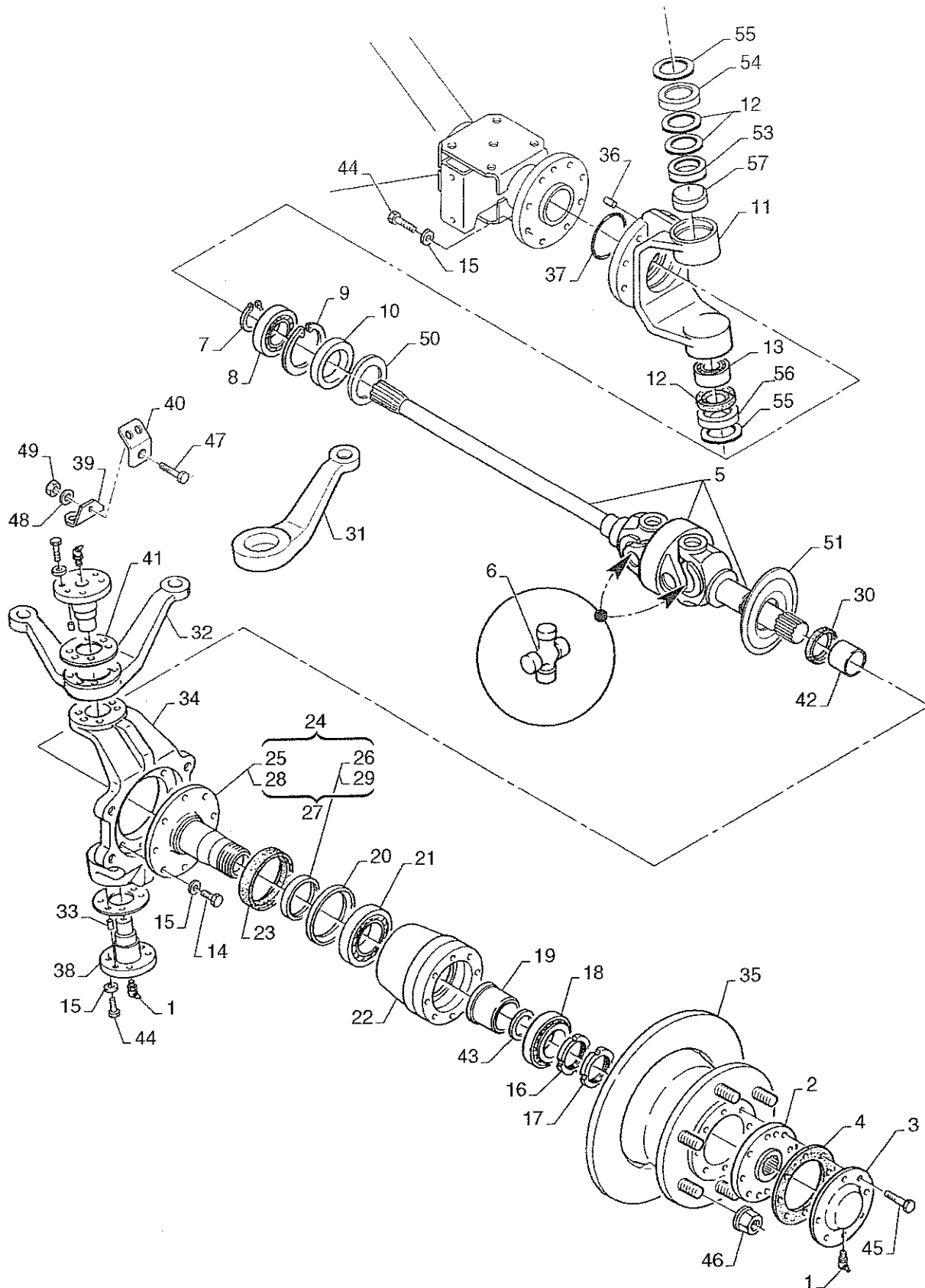

<input type="checkbox"/> 35	<input type="checkbox"/> TUR	<input type="checkbox"/> 20	<input type="checkbox"/> 4x4	<input type="checkbox"/> CEE	<input type="checkbox"/> YES	<input type="checkbox"/> NO
<input type="checkbox"/> 45	<input type="checkbox"/> E3					

BREMACH

Assale anteriore

TAV. **10.322**

Front axle

EXTREME Ed. 04 / 2002

N. Pos.	COD.	DENOMINAZIONE	Q.ty	DESCRIPTION	Da matricola Serial number
1	83375	Ingrassatore M6x1	4	Fitting	200001
2	90B4004	Flangia di trascinamento	2	Flange	200001
3	90B4007	Flangia per mozzo anteriore	2	Flange	200001
4	90B4003	Guarnizione mozzo anteriore	2	Gasket	200001
5	90B4020	Giunto omocinetico anteriore e semiassi	2	Joint	200001
6	90B0402	Crocera giunto ant.	4	Spider	200001
7	B1003	Seeger E 35	2	Seeger	200001
8	B1004	Cuscinetto 6207	2	Bearing	200001
9	B1005	Seeger I 72	2	Seeger	200001
10	B1006	MIM 45x72x8	2	MIM 45x72x8	200001
11	90B4019	Snodo interno	2	Joint	200001
12	90B4017	Anello di tenuta	6	Seal	200001
13	B1017	Cuscinetto (articolazione di steering) 25x52x22	2	Bearing	200001
14	201042	Vite M10x30	16	Bolt	200001
15	203004	Rosetta 10x20x2,3	40	Washer	200001
16	81041D	Ghiera destra	2	Ring nut RH	200001
17	81041S	Ghiera sinistra	2	Ring nut LH	200001
18	81036	Cuscinetto E0209	2	Bearing	200001
19	81043	Distanziale	2	Spacer	200001
20	81044	Disco protezione mozzo	2	Disc	200001
21	81053	Cuscinetto E0210	2	Bearing	200001
22	90B4005	Mozzo anteriore	2	Hub	200001
23	B1022	MIM 70x90x10	2	MIM 70x90x10	200001
24	B1026	Flangia completa mozzo destro	1	Complete flange RH	200001
25	B4002	. Flangia mozzo destro	1	. Flange RH	200001
26	B1020	. Anello per MIM	1	. Seal	200001
27	B1027	Flangia completa mozzo sinistro	1	Complete flange LH	200001
28	B4003	. Flangia mozzo sinistro	1	. Flange LH	200001
29	B1020	. Anello per MIM	1	. Seal	200001
30	B1023	MIM 35x47x7	2	MIM 35x47x7	200001
31	B1012	Leva semplice sterzo	1	Lever	200001
32	B1011	Leva sterzo ruota sinistra	1	Lever	200001
33	B1014	Spina riferimento leve sterzo	4	Pin	200001
34	90B4018	Snodo esterno	2	Joint	200001
35	92B9402	Disco freno completo	2	Complete disc	200001
36	A2033	Spina riferimento	2	Pin	200001
37	B1002	O.Ring 3256	2	O.Ring	200001
38	90B1028	Perno snodo ruote	4	Pin	200001
39	D4034	Contro piastrina per fissaggio tubi freno	2	Plate	200001
40	92F1020	Piastra fissaggio tubi flessibili freno	2	Plate	200001
41	B1013	Rasamento da 1 m	2	Adjusting shim	200001
42	B1024	Bronzina	2	Bush	200001
43	81052	Rasamento	2	Adjusting shim	200001
44	201039	Vite M 10x35	24	Bolt	200001
45	201083	Vite M 10x50x1,25	16	Bolt	200001
46	90C5004	Dado	12	Nut	200001
47	201020	Vite	1	Bolt	200001
48	203003	Rondella	1	Washer	200001
49	202004	Dado	1	Nut	200001
50	QT1296	Anello di protezione del semiassse	2	Seal	200001
51	QT1295	Anello di protezione del semiassse	2	Seal	200001
53	90B4015	Cuscinetto a rullini	2	Bearing	200001
54	90B4014	Anello di acciaio per alloggiamento tenuta	2	Seal	200001
55	90B4016	Anello di protezione	4	Seal	200001
56	90B4013	Anello di acciaio per alloggiamento tenuta	2	Seal	200001
57	90B4012	Anello per alloggiamento cuscinetto a rullini	2	Seal	200001

TAV. **10.323**

EXTREME Ed. 04 / 2002

Assale anteriore

Front axle

BREMACH

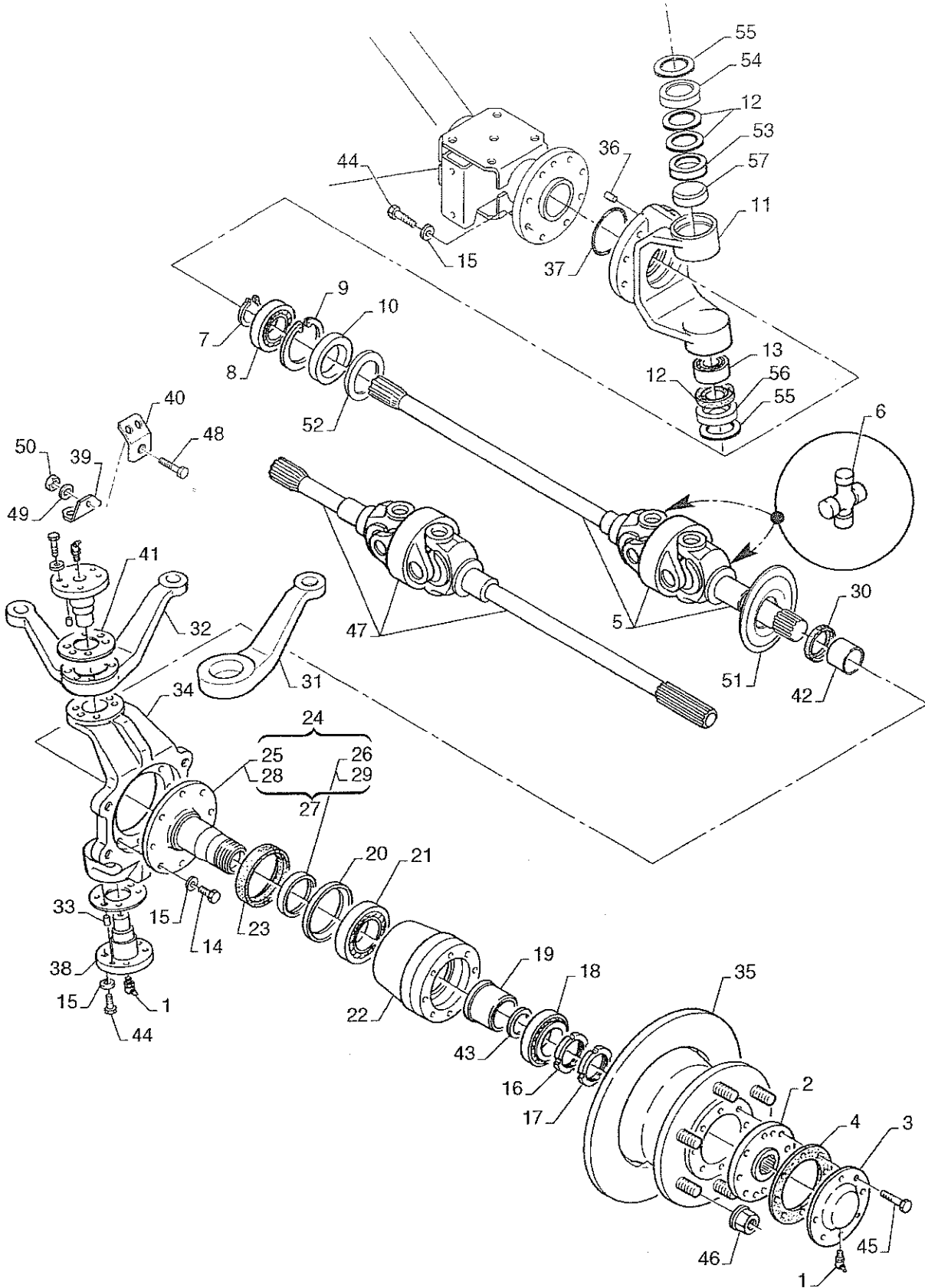

BREMACH

Assale anteriore

Front axle

TAV. **10.323**

EXTREME Ed. 04 / 2002

N. Pos.	COD.	DENOMINAZIONE	Q.ty	DESCRIPTION	Da matricola Serial number
1	83375	Ingrassatore M6x1	4	Fitting	200001
2	90B4004	Flangia di trascinamento	2	Flange	200001
3	90B4007	Flangia per mozzo anteriore	2	Flange	200001
4	90B4003	Guarnizione mozzo anteriore	2	Gasket	200001
5	90B4020	Giunto omocinetico anteriore e semiassi	1	Joint	200001
6	90B0402	Crocera giunto ant.	4	Spider	200001
7	B1003	Seeger E 35	2	Seeger	200001
8	B1004	Cuscinetto 6207	2	Bearing	200001
9	B1005	Seeger I 72	2	Seeger	200001
10	B1006	MIM 45x72x8	2	MIM 45x72x8	200001
11	90B4019	Snodo interno	2	Joint	200001
12	90B4017	Anello di tenuta	6	MIM 35x55x10	200001
13	B1017	Cuscinetto (articolazione di steering) 25x52x22	2	Bearing	200001
14	201042	Vite M10x30	16	Bolt	200001
15	203004	Rosetta 10x20x2,3	40	Washer	200001
16	81041D	Ghiera destra	2	Ring nut RH	200001
17	81041S	Ghiera sinistra	2	Ring nut LH	200001
18	81036	Cuscinetto E0209	2	Bearing	200001
19	81043	Distanziale	2	Spacer	200001
20	81044	Disco protezione mozzo	2	Disc	200001
21	81053	Cuscinetto E0210	2	Bearing	200001
22	90B4005	Mozzo anteriore	2	Hub	200001
23	B1022	MIM 70x90x10	2	MIM 70x90x10	200001
24	B1026	Flangia completa mozzo destro	1	Complete flange RH	200001
25	B4002	. Flangia mozzo destro	1	. Flange RH	200001
26	B1020	. Anello per MIM	1	. Seal	200001
27	B1027	Flangia completa mozzo sinistro	1	Complete flange LH	200001
28	B4003	. Flangia mozzo sinistro	1	. Flange LH	200001
29	B1020	. Anello per MIM	1	. Seal	200001
30	B1023	MIM 35x47x7	2	MIM 35x47x7	200001
31	B1012	Leva semplice sterzo	1	Lever	200001
32	B1011	Leva sterzo ruota sinistra	1	Lever	200001
33	B1014	Spina riferimento leve sterzo	4	Pin	200001
34	90B4018	Snodo esterno	2	Joint	200001
35	92B9402	Disco freno completo	2	Complete disc	200001
36	A2033	Spina riferimento	2	Pin	200001
37	B1002	O.Ring 3256	2	O.Ring	200001
38	90B1028	Perno snodo ruote	4	Pin	200001
39	D4034	Contro piastrina per fissaggio tubi freno	2	Plate	200001
40	92F1020	Piastra fissaggio tubi flessibili freno	2	Plate	200001
41	B1013	Rasamento da 1 m	2	Adjusting shim	200001
42	B1024	Bronzina	2	Bush	200001
43	81052	Rasamento	2	Adjusting shim	200001
44	201039	Vite M 10x35	24	Bolt	200001
45	201083	Vite M 10x50x1,25	16	Bolt	200001
46	90C5004	Dado	12	Nut	200001
47	90B4021	Giunto omocinetico ant.e semiassie lato bloccag.	1	Joint	200001
48	201020	Vite	1	Bolt	200001
49	203003	Rondella	1	Washer	200001
50	202004	Dado	1	Nut	200001
51	QT1295	Anello di protezione del semiassie	2	Seal	200001
52	QT1296	Anello di protezione del semiassie	2	Seal	200001
53	90B4015	Cuscinetto a rullini	2	Bearing	200001
54	90B4014	Anello di acciaio per alloggiamento tenuta	2	Seal	200001
55	90B4016	Anello di protezione	4	Seal	200001
56	90B4013	Anello di acciaio per alloggiamento tenuta	2	Seal	200001
57	90B4012	Anello per alloggiamento cuscinetto a rullini	2	Seal	200001

BREMACHDifferenziale posteriore
Rear differentialTAV. **10.412**

EXTREME Ed. 04 / 2002

N. Pos.	COD.	DENOMINAZIONE	Q.ty	DESCRIPTION	Da matricola Serial number
1	DIFFP00052	Differenziale posteriore completo	1	Complete differential	200001
2	80719	. Prigioniero	4	. Stud	200001
3	90A2004	. Bussola pignone	1	. Bush	200001
4	90A2013	. Ghiera regolazione differenziale	2	. Ring nut	200001
5	90A2014	. Piastrina ritegno ghiera differenziale	2	. Plate	200001
6	90A2015	. Cuscinetto	2	. Bearing	200001
7	90A2016	. Distanziale	1	. Spacer	200001
8	90A9208	. Campana	1	. Differential body	200001
9	90A2011	. Sede premistoppa differenziale	1	. Gasket housing	200001
10	90R1024	. Anello tenuta	1	. Seal	200001
11	90R1025	. Ghiera autobloccante	1	. Ring nut	200001
12	90R1026	. O.Ring	1	. O.Ring	200001
13	201080	. Vite M10x30x1,25	10	. Bolt	200001
14	202004	. Dado M8	4	. Nut	200001
15	203004	. Rosetta conica elastica 10x2x2,3	10	. Washer	200001
16	205003	. Copiglia ø 3,5x45	2	. Cotter	200001
17	90A2040	. Flangia per gardano ø 116	1	. Flange	200001
18	A9503	. Cuscinetto 32012	2	. Bearing	200001
19	90R1020	. Rasamento tipo PS 35x45x0,2	1	. Adjusting shim	200001
20	90R1032	. Rasamento tipo PS 35x45x0,1	1	. Adjusting shim	200001
21	90R1035	. Tappo lamiera	1	. Plug	200001
22	90A2021	. Innesto scorrevole blocco differenziale	1	. Differential lock lever	200001
23	203003	. Ranella	4	. Washer	200001
24	90A0920	. Coppia conica post. 9/46	1	. Bevel gear/pinion set	200001
25	90A2026	. Pignone Z9 spirale sx	1	. Pinion	200001
26	90A2027	. Corona Z46 spirale dx	1	. Crown	200001

TAV. 10.421

EXTREME Ed. 04 / 2002

Differenziale anteriore
Front differential

BREMACH

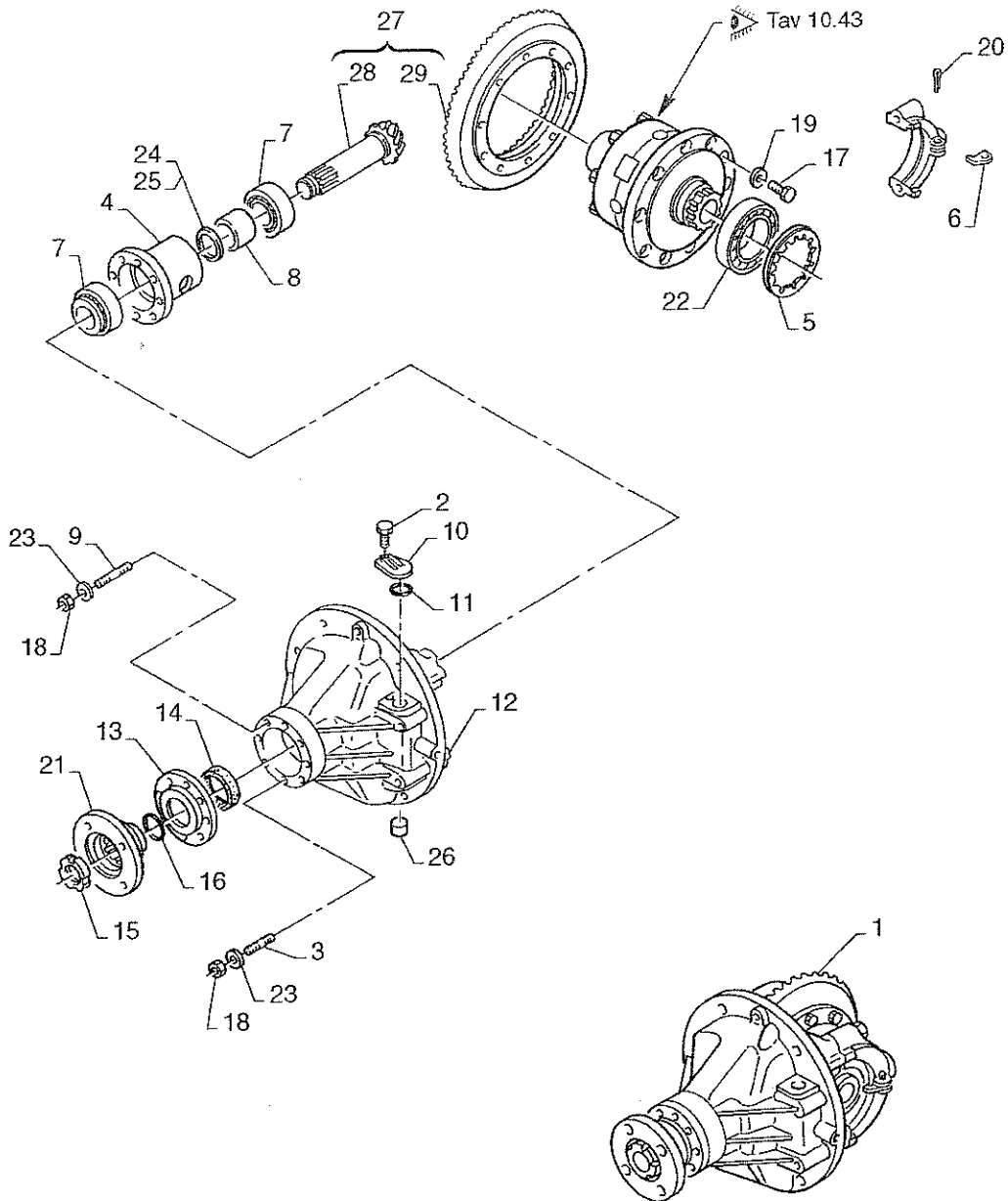

BREMACH

Differenziale anteriore

Front differential

TAV. **10.421**

EXTREME Ed. 04 / 2002

N. Pos.	COD.	DENOMINAZIONE	Q.ty	DESCRIPTION	Da matricola Serial number
1	DIFFA00053	Differenziale anteriore completo	1	Complete differential	200001
2	201021	. Vite	1	. Bolt	200001
3	80719	. Prigioniero	4	. Stud	200001
4	90A2004	. Bussola pignone	1	. Bush	200001
5	90A2013	. Ghiera regolazione differenziale	2	. Ring nut	200001
6	90A2014	. Piastrina ritegno ghiera differenziale	2	. Plate	200001
7	90A2015	. Cuscinetto	2	. Bearing	200001
8	90A2016	. Distanziale	1	. Spacer	200001
9	90A2029	. Prigioniero staffa blocco differenziale	4	. Stud	200001
10	90A2030	. Tappo	1	. Plug	200001
11	90A2031	. Anello di tenuta O.R.	1	. Seal	200001
12	90A9208	. Campana	1	. Differential body	200001
13	90A2011	. Sede premistoppa differenziale	1	. Gasket housing	200001
14	90R1024	. Anello tenuta	1	. Seal	200001
15	90R1025	. Ghiera autobloccante	1	. Ring nut	200001
16	90R1026	. O.Ring	1	. O.Ring	200001
17	201080	. Vite M10x30x1,25	10	. Bolt	200001
18	202004	. Dado M8 UNI 5587-68	8	. Nut	200001
19	203004	. Rosetta conica elastica 10x2x2,3	10	. Washer	200001
20	205003	. Copiglia ø 3,5x45	2	. Cotter	200001
21	90A2040	. Flangia per cardano ø 116	1	. Flange	200001
22	A9503	. Cuscinetto 32012	2	. Bearing	200001
23	203003	. Ranella conica elastica 8x16x1	8	. Washer	200001
24	90R1020	. Rasamento tipo PS 35x45x0,2	1	. Adjusting shim	200001
25	90R1032	. Rasamento tipo PS 35x45x0,1	1	. Adjusting shim	200001
26	90R1035	. Tappo lamiera	1	. Plug	200001
27	90B0920	. Coppia conica anteriore 9/46	1	. Bevel gear/pinion set	200001
28	90B2004	.. Pignone z=9 spirale destra	1	.. Pinion	200001
29	90B2005	.. Corona z=46 spirale sinistra	1	.. Crown	200001

TAV. 10.422

EXTREME Ed. 04 / 2002

Differenziale anteriore
Front differential

BREMACH

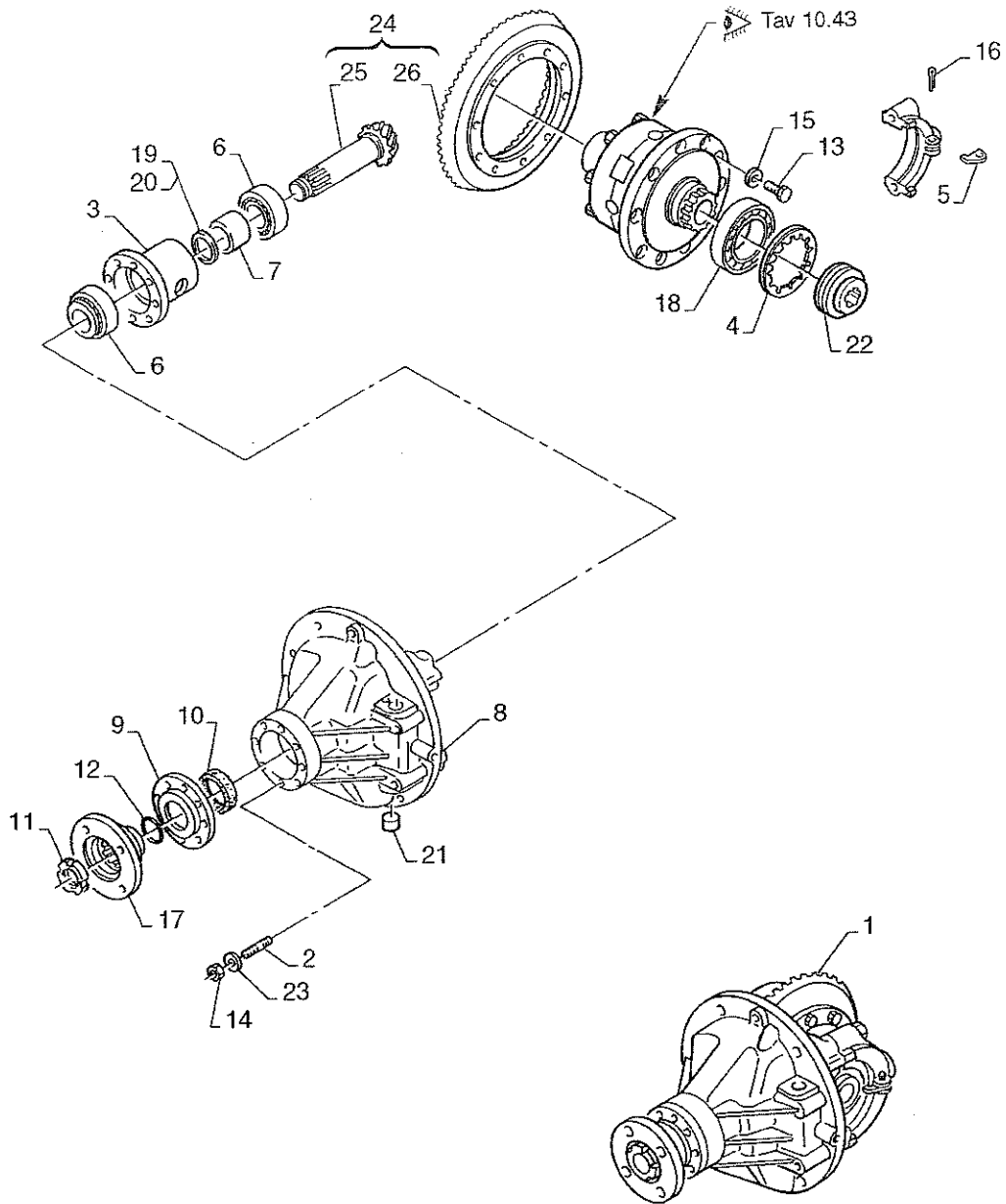

<input type="checkbox"/> 35 <input type="checkbox"/> 45	TUR <input type="checkbox"/> E3	20	4x4	<input type="checkbox"/> <input type="checkbox"/>	<input type="checkbox"/> <input type="checkbox"/>	CEE <input type="checkbox"/>	<input type="checkbox"/> <input type="checkbox"/>	<input type="checkbox"/> <input type="checkbox"/>	<input type="checkbox"/> YES <input type="checkbox"/> NO
------------------------------------------------------------	------------------------------------	----	-----	---------------------------------------------------	---------------------------------------------------	---------------------------------	---------------------------------------------------	---------------------------------------------------	-------------------------------------------------------------

BREMACHDifferenziale anteriore
Front differentialTAV. **10.422**

EXTREME Ed. 04 / 2002

N. Pos.	COD.	DENOMINAZIONE	Q.ty	DESCRIPTION	Da matricola Serial number
1	DIFFA00056	Differenziale anteriore completo SL	1	Complete differential	200001
2	80719	. Prigioniero	4	. Stud	200001
3	90A2004	. Bussola pignone	1	. Bush	200001
4	90A2013	. Ghiera regolazione differenziale	2	. Ring nut	200001
5	90A2014	. Piastrina ritegno ghiera differenziale	2	. Plate	200001
6	90A2015	. Cuscinetto	2	. Bearing	200001
7	90A2016	. Distanziale	1	. Spacer	200001
8	90A9208	. Campana	1	. Differential body	200001
9	90A2011	. Sede premistoppa differenziale	1	. Gasket housing	200001
10	90R1024	. Anello tenuta	1	. Seal	200001
11	90R1025	. Ghiera autobloccante	1	. Ring nut	200001
12	90R1026	. O.Ring	1	. O.Ring	200001
13	201080	. Vite M10x30x1,25	10	. Bolt	200001
14	202004	. Dado M8	4	. Nut	200001
15	203004	. Rosetta conica elastica 10x2x2,3	10	. Washer	200001
16	205003	. Copiglia ø 3,5x45	2	. Cotter	200001
17	90A2040	. Flangia per cardano ø 116	1	. Flange	200001
18	A9503	. Cuscinetto 32012	2	. Bearing	200001
19	90R1020	. Rasamento tipo PS 35x45x0,2	1	. Adjusting shim	200001
20	90R1032	. Rasamento tipo PS 35x45x0,1	1	. Adjusting shim	200001
21	90R1035	. Tappo lamiera	1	. Plug	200001
22	90A2021	. Innesto scorrevole blocco differenziale	1	. Differential lock lever	200001
23	203003	. Ranella	4	. Washer	200001
24	90B0920	. Coppia conica anteriore 9/46	1	. Bevel gear/pinion set	200001
25	90B2004	. . Pignone Z9 spirale dx	1	. . Pinion	200001
26	90B2005	. . Corona Z46 spirale sx	1	. . Crown	200001

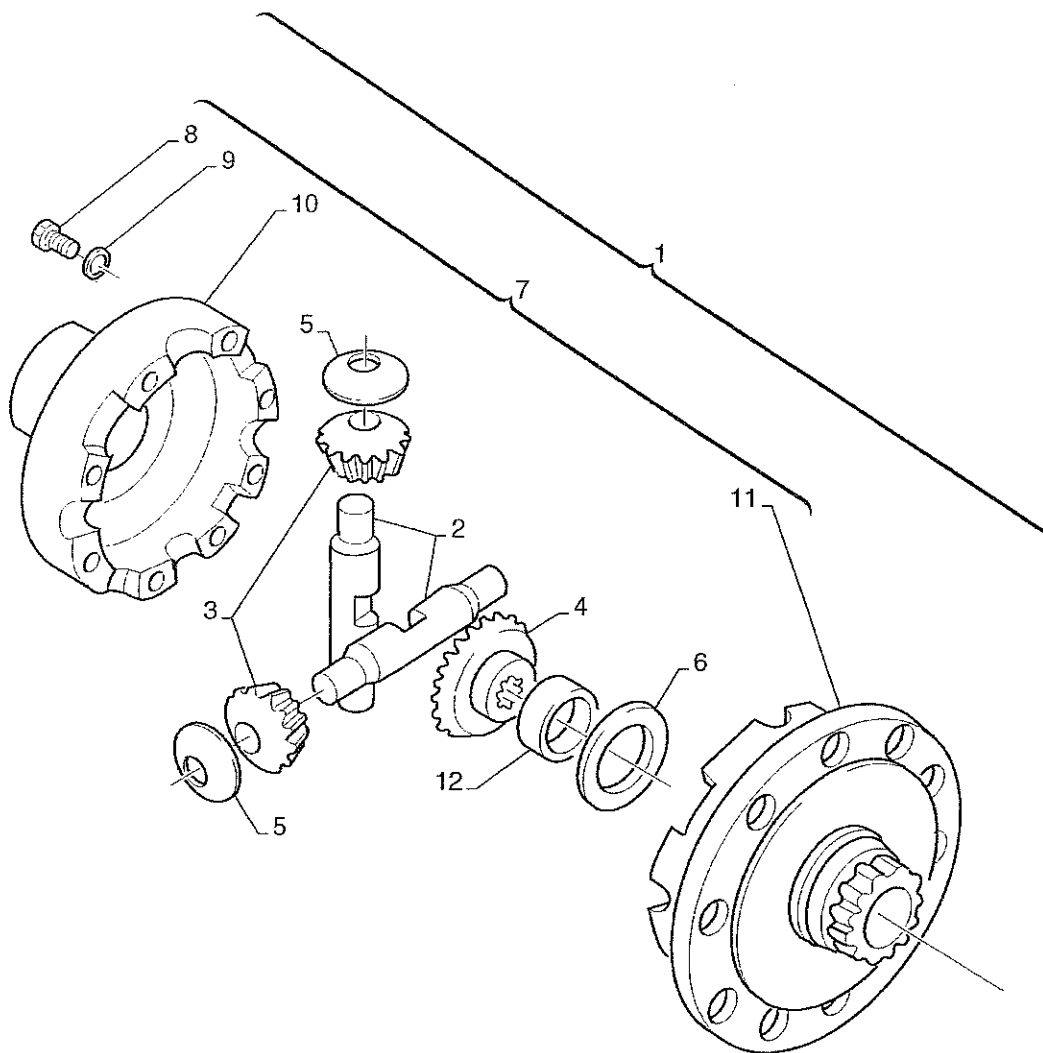

BREMACHScatola porta satelliti
Planetary boxTAV. **10.43**
EXTREME Ed. 04 / 2002

N. Pos.	COD.	DENOMINAZIONE	Q.ty	DESCRIPTION	Da matricola Serial number
1	90A9205.00	Scatola porta satelliti completa	1	Box	
2	90A2035	. Perno porta satellite	2	. Pin	200001
3	A9016	. Satellite	4	. Planetary	200001
4	A9017	. Planetario	2	. Side gear	200001
5	80731	. Rasamento satellite	4	. Adjusting shim	200001
6	80733	. Rasamento planetario	2	. Adjusting shim	200001
7	90A9205	. Scatola porta satelliti	1	. Box	200001
8	201030	.. Vite M8x60	8	.. Bolt	200001
9	203103	.. Rondella piana	8	.. Washer	200001
10	90A2037	.. Semiscatola lato corona	1	.. Housing	200001
11	90A2038	.. Semiscatola	1	.. Housing	200001
12	90A9205	.. Bronzina	1	.. Bush	200001

TAV. 10.441

EXTREME Ed. 04 / 2002

Tiranteria bloccaggio elettrico differenziale posteriore

Rear electric differential interlock linkage

BREMACH

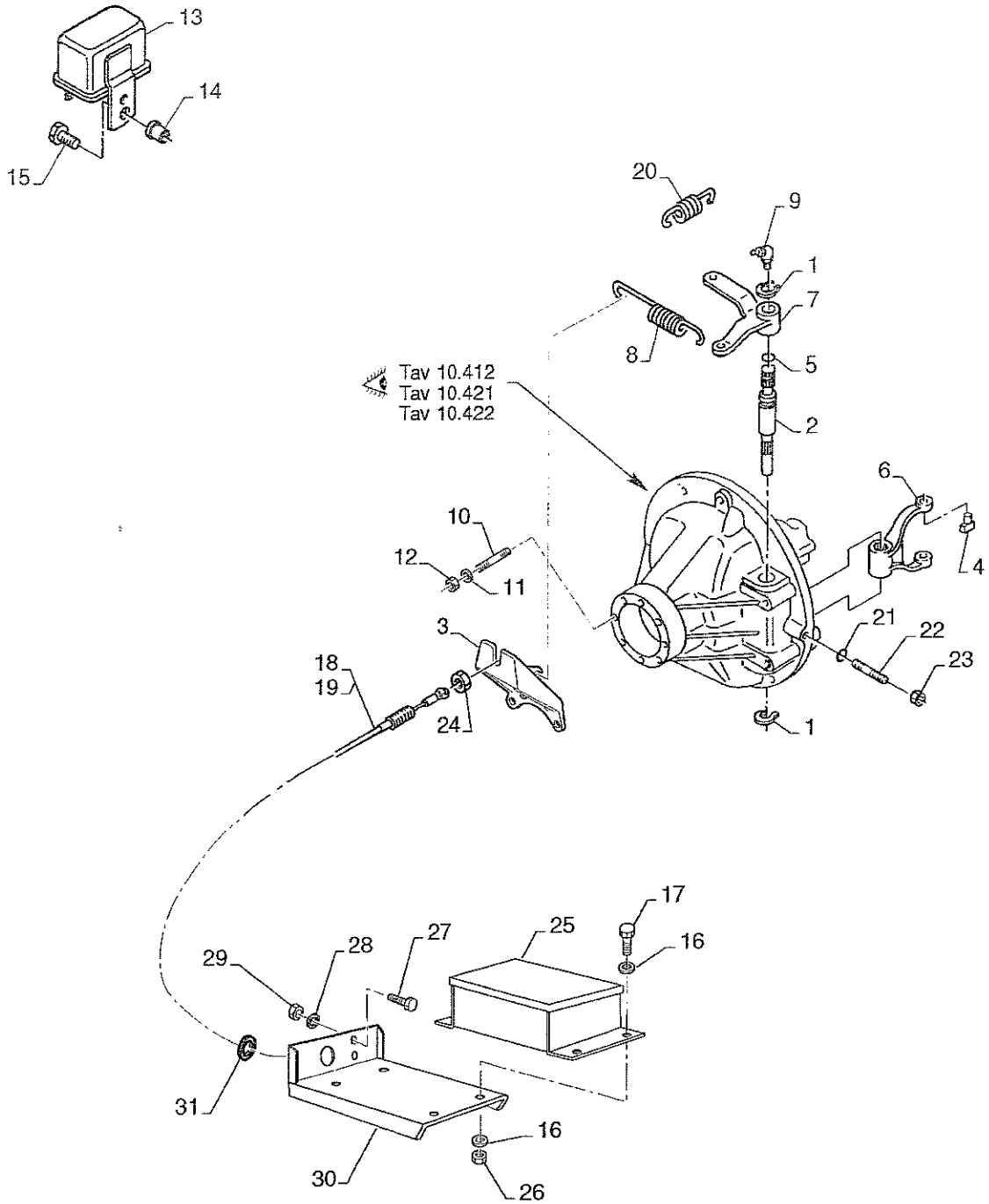

BREMACHTiranteria bloccaggio elettrico differenziale posteriore
Rear electric differential interlock linkageTAV. **10.441**

EXTREME Ed. 04 / 2002

N. Pos.	COD.	DENOMINAZIONE	Q.ty	DESCRIPTION	Da matricola Serial number
1	A9545	Seeger E18	3	Seeger	200001
2	90A2018	Albero forcella blocco differenziale	1	Shaft	200001
3	90A2024	Supporto per dado bloccaggio differenziale	1	Support	200001
4	A2017	Farfalla per forcella innesto	2	Butterfly nut	200001
5	A3010	O.Ring (5,68x2,62)	1	O.Ring	200001
6	90A2003	Forcella per blocco differenziale	1	Fork	200001
7	90A2007	Leva doppia comando blocco differenziale	1	Lever	200001
8	90A2022	Molla di richiamo	1	Spring	200001
9	83375	Ingrassatore dritto	1	Fitting	200001
10	90A2029	Prigioniero staffa blocco differenziale	4	Stud	200001
11	203003	Ranella	4	Washer	200001
12	202102	Dado M8 autobloc. UNI 7473	4	Nut	200001
13	A9540	Cicalina 12 V di segnalazione blocco diff.	1	Buzzer	200001
14	E4111	Bussola M5 0917-25 per install. cicalina	1	Bush	200001
15	201001	Vite M5x16 UNI 5739-65	1	Bolt	200001
16	203110	Rondella elastica	8	Washer	200001
17	201021	Vite	8	Bolt	200001
18	90L2001	Cavo comando innesto diff. post. passo 2600	1	Cable	200001
19	90L2002	Cavo comando innesto diff. post. passo 3000	1	Cable	200001
20	90A2023	Molla di innesto	1	Spring	200001
21	90A2019	Rondella	1	Washer	200001
22	90A2020	Prigioniero	1	Stud	200001
23	202202	Dado	1	Nut	200001
24	A9542	Dado	1	Nut	200001
25	90L2007	Bloccaggio differenziale elettrico	1	Electric differential interlock	200001
26	202004	Dado	4	Nut	200001
27	201041	Vite TE	2	Bolt	200001
28	203004	Rondella	2	Washer	200001
29	202103	Dado	2	Nut	200001
30	QT1299	Mensola di supporto	1	Support	200001
31	92P6017	Gommino	1	Rubber	200001

TAV. 10.442

EXTREME Ed. 04 / 2002

Tiranteria bloccaggio elettrico differenziale anteriore

Front electric differential interlock linkage

BREMACH

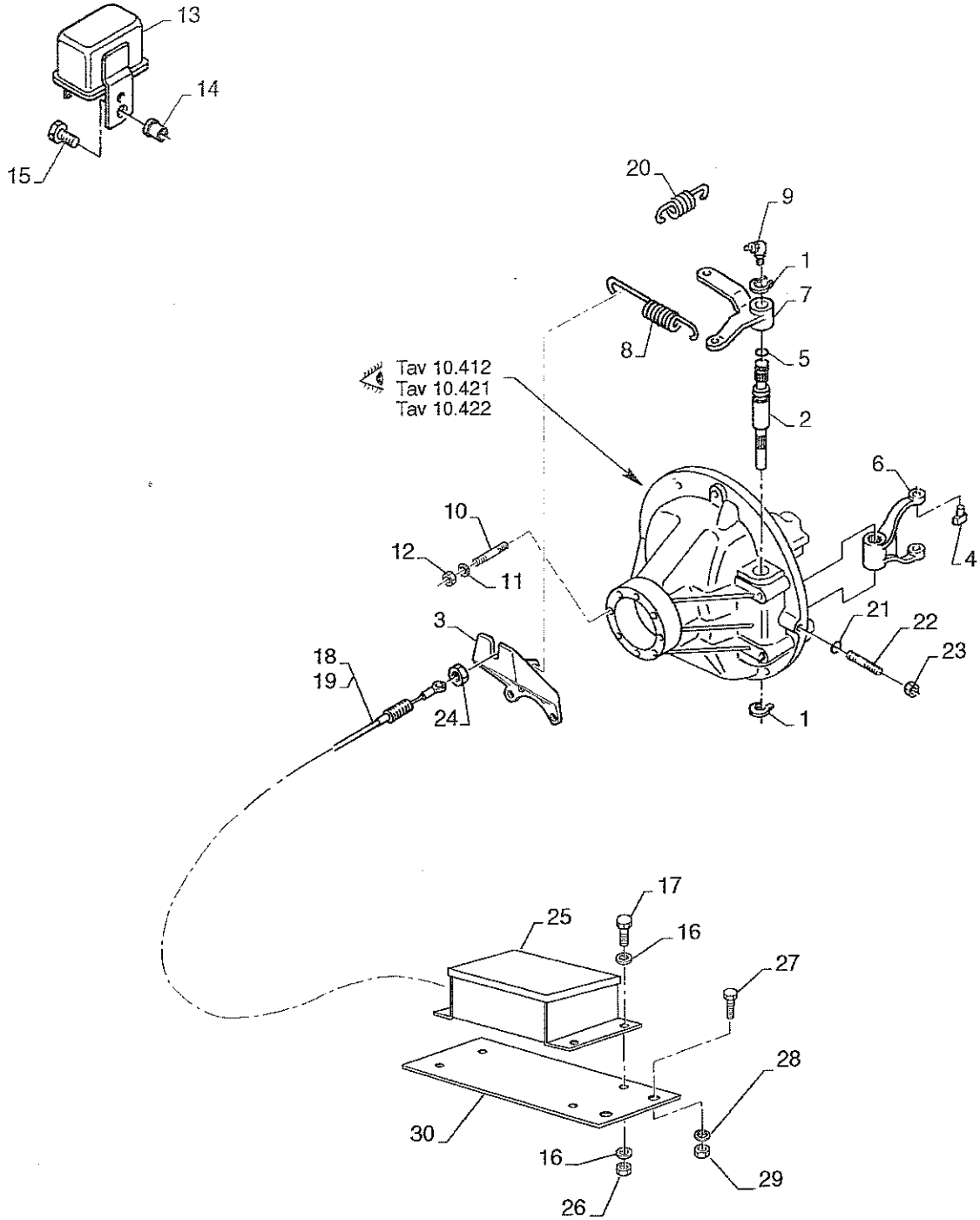

<input type="checkbox"/> 35 <input type="checkbox"/> 45	TUR <input type="checkbox"/> ES	<input type="checkbox"/> 20	<input type="checkbox"/> 4x4	<input type="checkbox"/>	<input type="checkbox"/>	<input type="checkbox"/>	CEE <input type="checkbox"/>	<input type="checkbox"/>	<input type="checkbox"/>	<input type="checkbox"/> YES <input type="checkbox"/> NO
------------------------------------------------------------	------------------------------------	-----------------------------	------------------------------	--------------------------	--------------------------	--------------------------	---------------------------------	--------------------------	--------------------------	-------------------------------------------------------------

BREMACHTiranteria bloccaggio elettrico differenziale anteriore
Front electric differential interlock linkageTAV. **10.442**

EXTREME Ed. 04 / 2002

N. Pos.	COD.	DENOMINAZIONE	Q.ty	DESCRIPTION	Da matricola Serial number
1	A9545	Seeger E18	3	Seeger	200001
2	90A2018	Albero forcella blocco differenziale	1	Shaft	200001
3	90A2024	Supporto per dado bloccaggio differenziale	1	Support	200001
4	A2017	Farfalla per forcella innesto	2	Butterfly nut	200001
5	A3010	O.Ring (5,68x2,62)	1	O.Ring	200001
6	90A2003	Forcella per blocco differenziale	1	Fork	200001
7	90A2007	Leva doppia comando blocco differenziale	1	Lever	200001
8	90A2022	Molla di richiamo	1	Spring	200001
9	83375	Ingrassatore dritto	1	Fitting	200001
10	90A2029	Prigioniero staffa blocco differenziale	4	Stud	200001
11	203003	Ranella	4	Washer	200001
12	202102	Dado M8 autobloc. UNI.7473	4	Nut	200001
13	A9540	Cicalina 12 V di segnalazione blocco diff.	1	Buzzer	200001
14	E4111	Bussoia M5 0917-25 per install. cicalina	1	Bush	200001
15	201001	Vite M5x16 UNI 5739-65	1	Bolt	200001
16	203110	Rondella	1	Washer	200001
17	201021	Vite	1	Bolt	200001
18	90L1004	Cavo comando innesto	1	Cable	200001
20	90A2023	Molla di innesto	1	Spring	200001
21	90A2019	Rondella	1	Washer	200001
22	90A2020	Prigioniero	1	Stud	200001
23	202202	Dado	1	Nut	200001
24	A9542	Dado	1	Nut	200001
25	90L2007	Bloccaggio differenziale elettrico	1	Electric differential interlock	200001
26	202004	Dado	4	Nut	200001
27	201041	Vite TE	2	Bolt	200001
28	203004	Rondella	2	Washer	200001
29	202103	Dado	2	Nut	200001
30	90N2010	Piastra di alluminio per supporto	1	Support	200001

EXTREME

**Gruppo
Group**

20

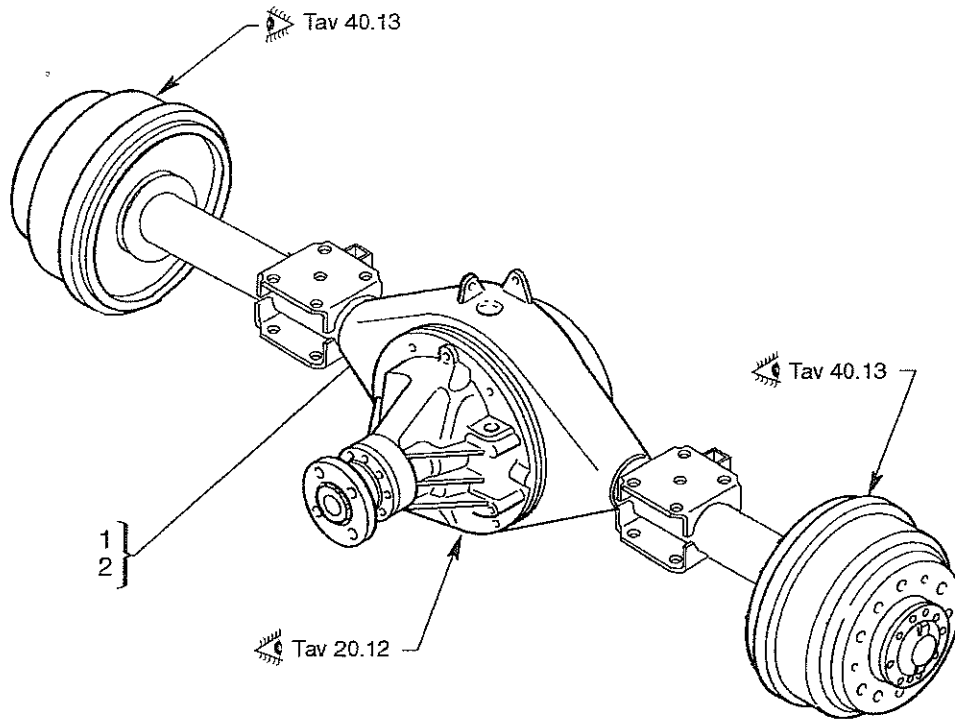

BREMACHPonte posteriore completo
Complete rear axleTAV. **20.11**
EXTREME Ed. 04 / 2002

N. Pos.	COD.	DENOMINAZIONE	Q.ty	DESCRIPTION	Da matricola Serial number
1	PONTP00069	Ponte BRICK PO 3,5 20M 9/46 BL	1	Axle	200001
2	PONTP00083	Ponte BRICK PO 5,0 20M 9/46 BL	1	Axle	200001

BREMACHPonte posteriore (struttura portante)
Rear axle (cerryng structure)TAV. **20.12**

EXTREME Ed. 04 / 2002

N. Pos.	COD.	DENOMINAZIONE	Q.ty	DESCRIPTION	Da matricola Serial number
1	80751	Tappo sfiato	1	Plug	200001
2	80753	Tappo carico olio	1	Plug	200001
3	80754	Guarnizione tappo carico olio	1	Gasket	200001
4	90A2008	Calotta chiusura differenziale	1	Calotte	200001
5	90A2010	Spina di centraggio	2	Pin	200001
6	OSSAP00050	Armatura ponte posteriore (35)	1	Rear axle case	200001
7	90A4008	Spina di centraggio	2	Pin	200001
8	A7005	Tappo M 20x1 dim. 9065.8	1	Plug	200001
9	201023	Vite M 8x30	6	Bolt	200001
10	201032	Vite M 8x80	2	Bolt	200001
11	201026	Vite M 8x40	10	Bolt	200001
12	203003	Rondella 8x16x1	20	Washer	200001
13	83550	Sigillante (Sui due lati)	1	Siling	200001
14	201024	Vite M 8x35	2	Bolt	200001
15	90A9208	Assieme campana differenziale	1	Differential assy	200001
16	90A2032	. Prigioniero	4	. Stud	200001
17	202114	. Dado autobloccante	4	. Self-locking nut	200001
18	80473	. Spina	4	. Pin	200001
19	OSSAP00059	Armatura ponte posteriore (45)	1	Rear axle case	200001

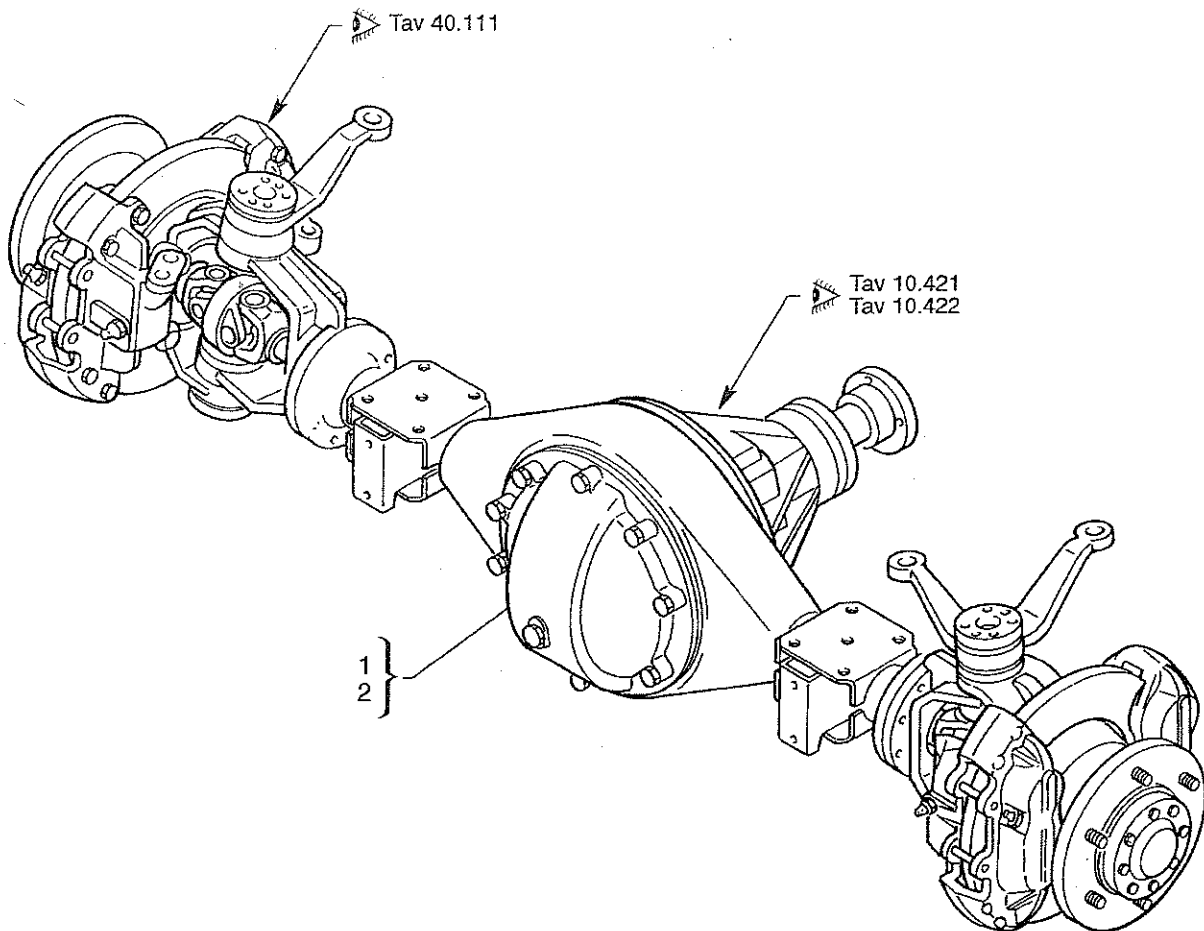

BREMACH

Ponte anteriore completo

Complete front axle

TAV. **20.21**

EXTREME Ed. 04 / 2002

N. Pos.	COD.	DENOMINAZIONE	Q.ty	DESCRIPTION	Da matricola Serial number
1	PONTA00052	Ponte anteriore 4x4 9/46 autoventilato	1	Axle	200001
2	PONTA00054	Ponte anteriore 4x4 9/46 BL. autoventilato	1	Axle	200001

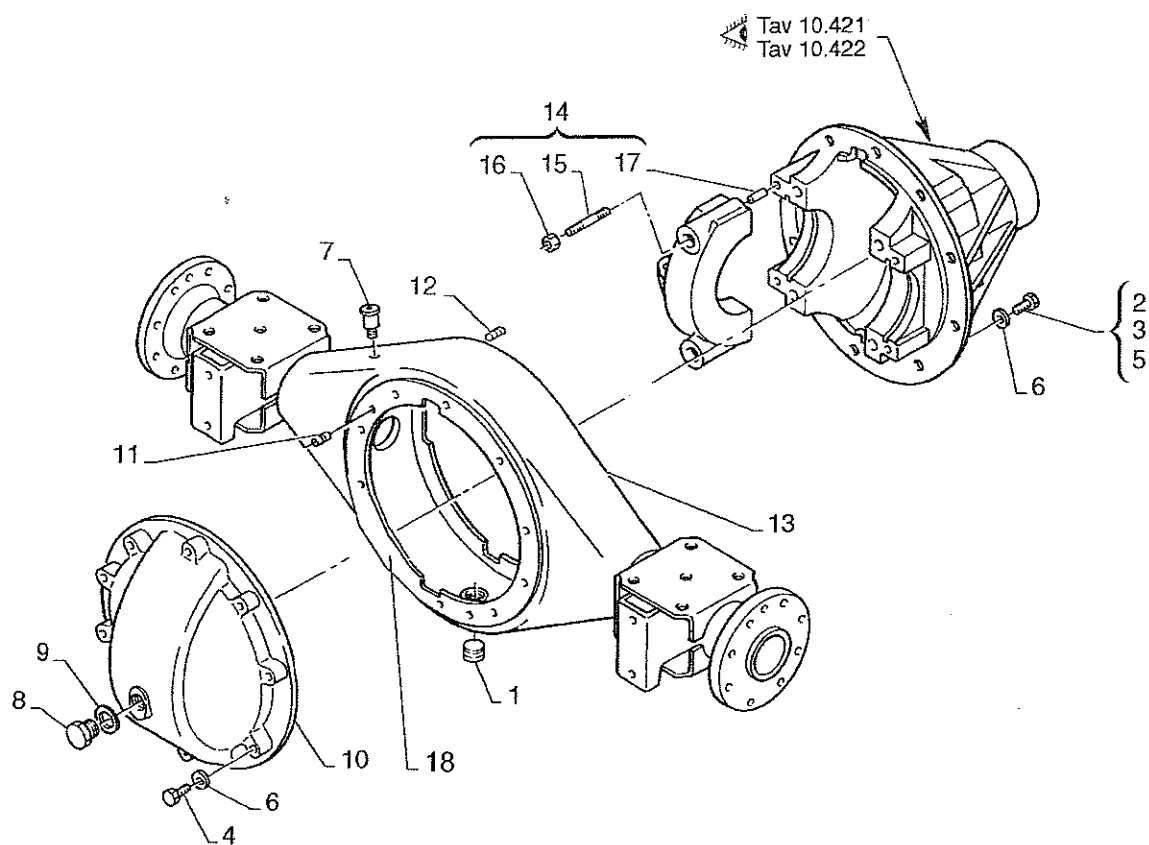

BREMACH

Ponte anteriore (struttura portante)

TAV. **20.221**

Front axle (cerryng structure)

EXTREME Ed. 04 / 2002

N. Pos.	COD.	DENOMINAZIONE	Q.ty	DESCRIPTION	Da matricola Serial number
1	A7005	Tappo M 20x1,5	1	Plug	200001
2	201023	Vite M 8x30	6	Bolt	200001
3	201024	Vite M 8x35	2	Bolt	200001
4	201026	Vite M 8x40	10	Bolt	200001
5	201032	Vite M 8x80	2	Bolt	200001
6	203003	Rondella 8x16x1,9	20	Washer	200001
7	80751	Tappo sfiato	1	Plug	200001
8	80753	Tappo carico olio	1	Plug	200001
9	80754	Guarnizione tappo 20x30x2	1	Gasket	200001
10	90A2008	Calotta bloccaggio differenziale	1	Calotte	200001
11	90A4008	Spina di centraggio	2	Pin	200001
12	90A2010	Spina di centraggio	2	Pin	200001
13	OSSAN00050	Armatura ponte anteriore 4x4	1	Front axle case	200001
14	90A9208	Assieme campana differenziale	1	Differential assy	200001
15	90A2032	. Prigioniero	4	. Stud	200001
16	202110	. Dado autobloccante	4	. Self-locking nut	200001
17	80473	. Spina	4	. Pin	200001
18	83550	Sigillante (sui due lati)		Silling	200001

EXTREME

**Gruppo
Group**

30

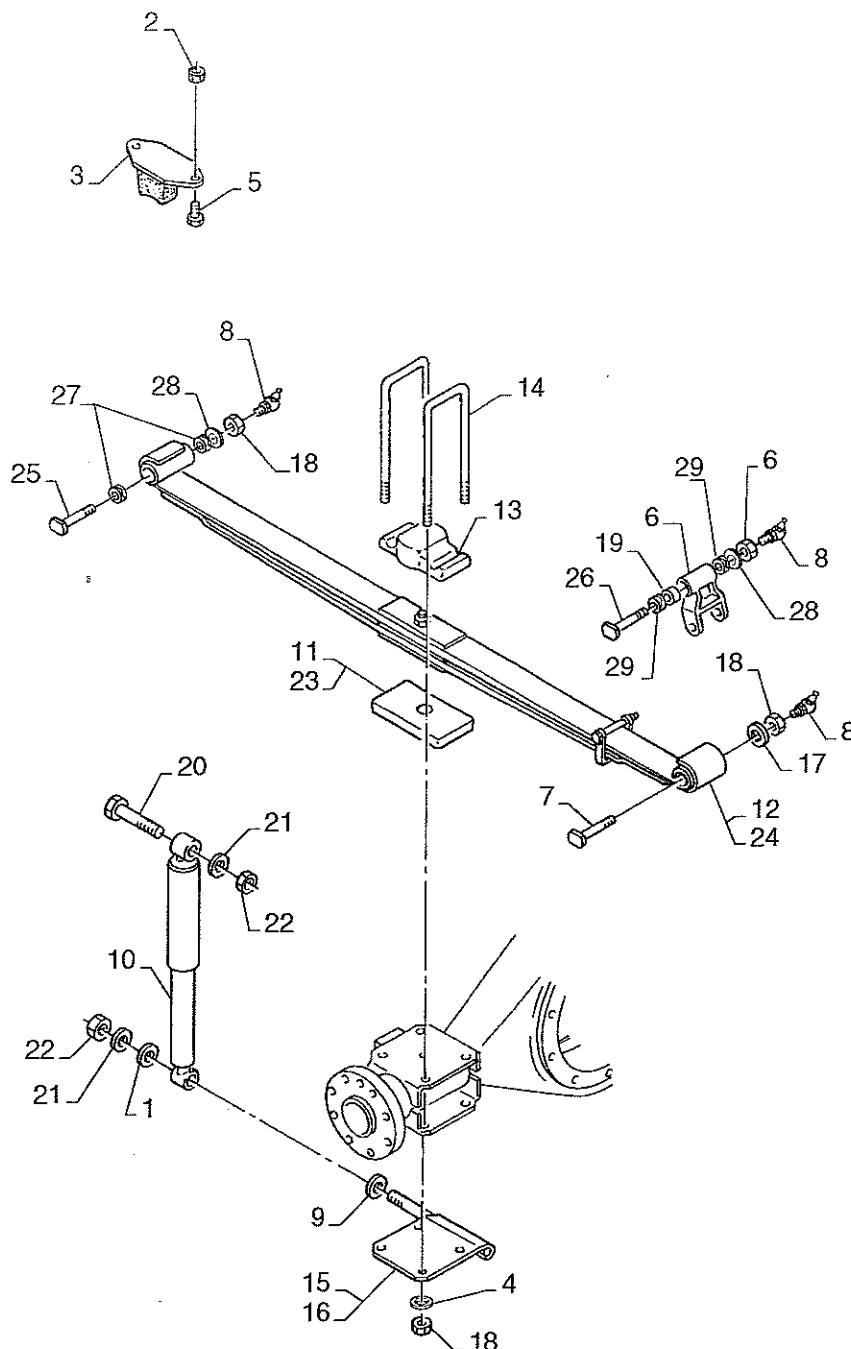

BREMACHSospensione anteriore
Front-wheel suspensionTAV. **30.11**

EXTREME Ed. 04 / 2002

N. Pos.	COD.	DENOMINAZIONE	Q.ty	DESCRIPTION	Da matricola Serial number
1	203109	Rondella piana	2	Washer	200001
2	202102	Dado M8 autobloccante	4	Self-locking nut	200001
3	90A1001	Tampone	2	Plug	200001
4	203005	Rondella	1	Washer	200001
5	201022	Vite M 8x25	4	Bolt	200001
6	B6036	Biella balestre telaio	2	Rod	200001
7	B6035	Spinotto attacco balestra	2	Connector	200001
8	D4032	Ingrassatore	6	Fitting	200001
9	90A1007	Rondella per ammortizzatore	2	Washer	200001
10	92B1006	Ammortizzatore anteriore	2	Shock absorber	200001
11	90B9103	Distanziale balestra H=25 (35 q.li)	2	Spacer	200001
12	90A9411	Assieme balestra anteriore e bussola (35 q.li)	2	Front spring assy and bush	200001
13	90A1009	Piastra battuta tampone	2	Plate	200001
14	90B1002	Cavalotto di collegamento	4	U-Bolt	200001
15	90A1025D	Piastra per ammortizzatore destro	1	Plate	200001
16	90A1025S	Piastra per ammortizzatore sinistro	1	Plate	200001
17	203005	Rondella 12x24x2,8	4	Washer	200001
18	202104	Dado M12	14	Nut	200001
19	B6037	Boccola nylon	2	Bushing	200001
20	201060	Vite M 16x65	2	Bolt	200001
21	203201	Ranella 17x27x3,5	4	Washer	200001
22	202008	Dado M16	4	Nut	200001
23	90B9102	Distanziale balestra H=15 (45 q.li)	2	Spacer	200001
24	90A9413	Assieme balestra anteriore e bussola (45 q.li)	2	Front spring assy and bush	200001
25	90B1027	Perni anteriori balestra	2	Pin	200001
26	90A1028	Perni posteriori balestra	2	Pin	200001
27	90A1030	Bussole anteriori balestra ant.	4	Front-wheel bush	200001
28	90A1032	Rondella	4	washer	200001
29	90A1029	Bussole posteriori balestra ant.	4	Rear-wheel bush	200001

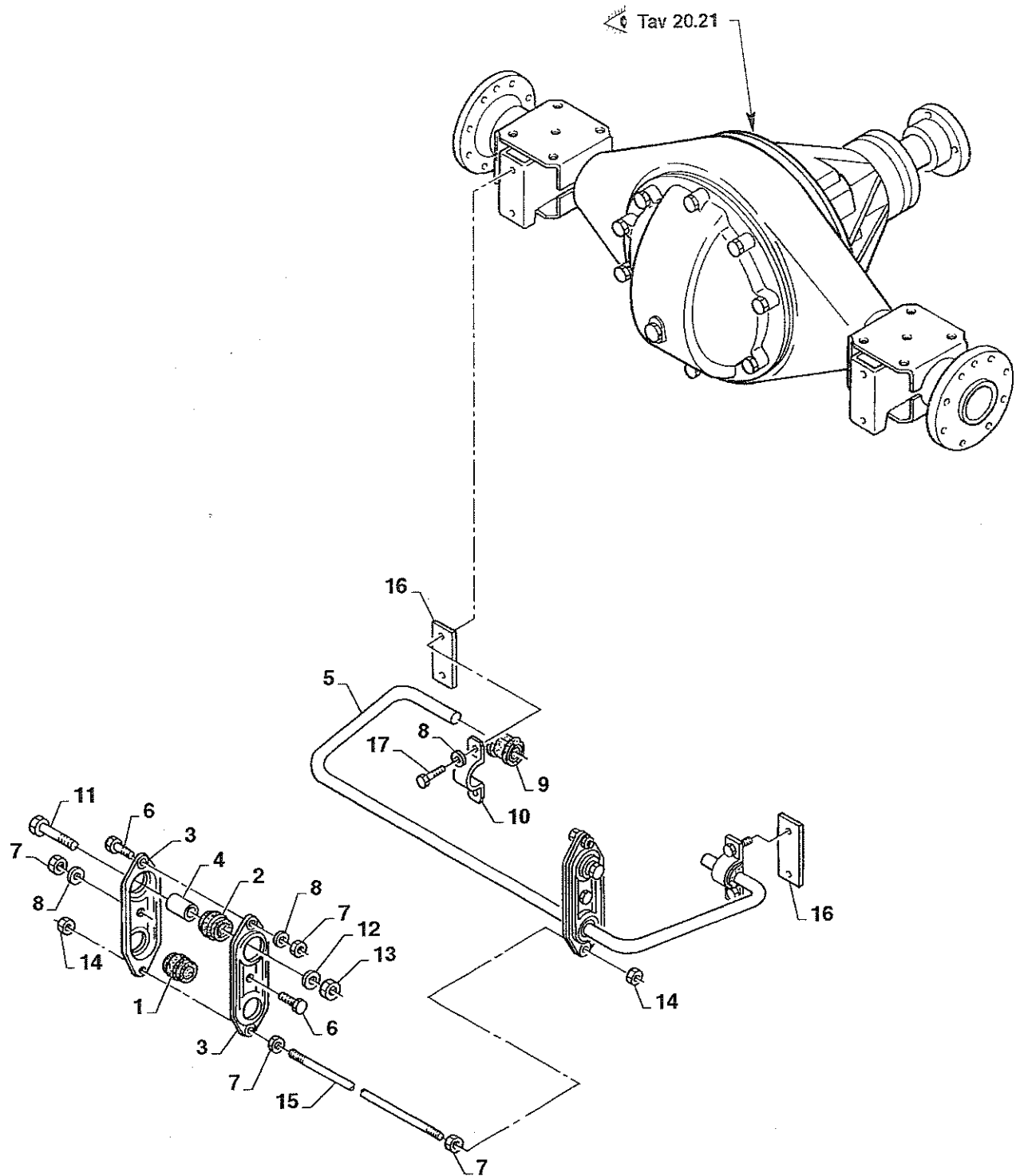

BREMACHBarra stabilizzatrice anteriore
Front main anti-roll barTAV. **30.122**

EXTREME Ed. 04 / 2002

N. Pos.	COD.	DENOMINAZIONE	Q.ty	DESCRIPTION	Da matricola Serial number
1	B6014	Gommino barra biella	2	Rubber	200001
2	B6015	Gommino biella telaio	2	Rubber	200001
3	B6016	Semi biella	4	Main rod	200001
4	B6017	Bussola biella	2	Bush	200001
5	90B1001	Barra di torsione	1	Torsion bear	200001
6	201040	Vite M 10x20	8	Bolt	200001
7	202005	Dado M 10	6	Nut	200001
8	203004	Rondella conica elastica	8	Washer	200001
9	B6013	Gommino barra ponte	2	Rubber	200001
10	B6012	Cavallotto barra torsione ponte	2	Rubber	200001
11	201061	Vite M 16x80	2	Bolt	200001
12	203201	Rondella 17x27x3,5	2	Washer	200001
13	202008	Dado M16	2	Nut	200001
14	202103	Dado	2	Nut	200001
15	90B1005	Perno collegamento bielle barra torsione	1	Pin	200001
16	B6028	Distanziale barra stabilizzatrice	2	Spacer	200001
17	201042	Vite M 10x30	4	Bolt	200001

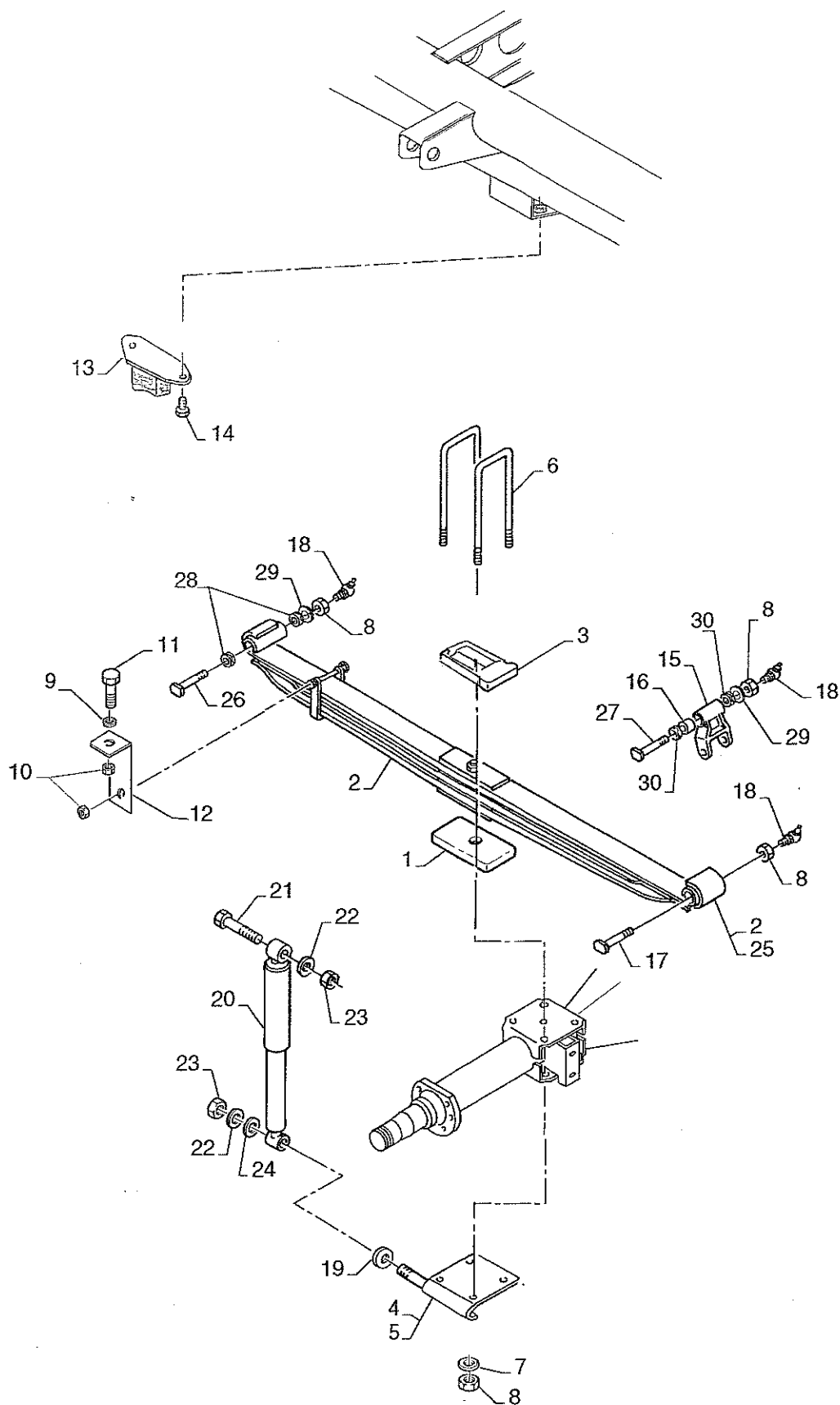

BREMACHSospensione posteriore
Rear-wheel suspensionTAV. **30.21**

EXTREME Ed. 04 / 2002

N. Pos.	COD.	DENOMINAZIONE	Q.ty	DESCRIPTION	Da matricola Serial number
1	90B9103	Assieme distanziale balestra H=25 (35 q.li)	2	Spacer	200001
2	90A9412	Balestra posteriore con bussole(35 q.li)	2	Suspension leaf spring	200001
3	90A1011	Piastra balestra	2	Plate	200001
4	90A1025D	Piastra ammortizzatore destra	1	Plate	200001
5	90A1025S	Piastra ammortizzatore sinistra	1	Plate	200001
6	90A1005	Cavalotto balestra	4	Rubber	200001
7	203005	Rondella elastica 12x24x2,8	4	Washer	200001
8	202104	Dado M12 autobloccante	8	Nut	200001
9	203003	Rondella elastica 8x16x1,9	2	Washer	200001
10	202004	Dado M8	4	Nut	200001
11	201020	Vite M 8x16	2	Bolt	200001
12	90L4007	Supporto cavo freno a mano	2	Support	200001
13	90A1001	Tampone	2	Plug	200001
14	201022	Vite M 8x25	4	Bolt	200001
15	B6036	Biella balestra telaio	2	Rod	200001
16	B6037	Boccola	2	Bushing	200001
17	B6035	Spinotto attacco balestra	2	Connector	200001
18	D4032	Ingrassatore	12	Fitting	200001
19	90A1007	Rondella per ammortizzatore	2	Washer	200001
20	90A1034	Ammortizzatore posteriore	2	Shock absorber	200001
21	201060	Vite M 16x25	2	Bolt	200001
22	203201	Rosetta 17x27x3,5	4	Washer	200001
23	202008	Dado M16	4	Nut	200001
24	203109	Rondella piana	2	Washer	200001
25	90A9414	Balestra posteriore e bussole (45 q.li)	2	Suspension leaf spring	200001
26	90B1027	Perni anteriori balestra	2	Pin	200001
27	90A1028	Perni posteriori balestra	2	Pin	200001
28	90A1030	Bussole anteriori balestra ant.	4	Front-wheel bush	200001
29	90A1032	Rondella	4	washer	200001
30	90A1029	Bussole posteriori balestra ant.	4	Rear-wheel bush	200001

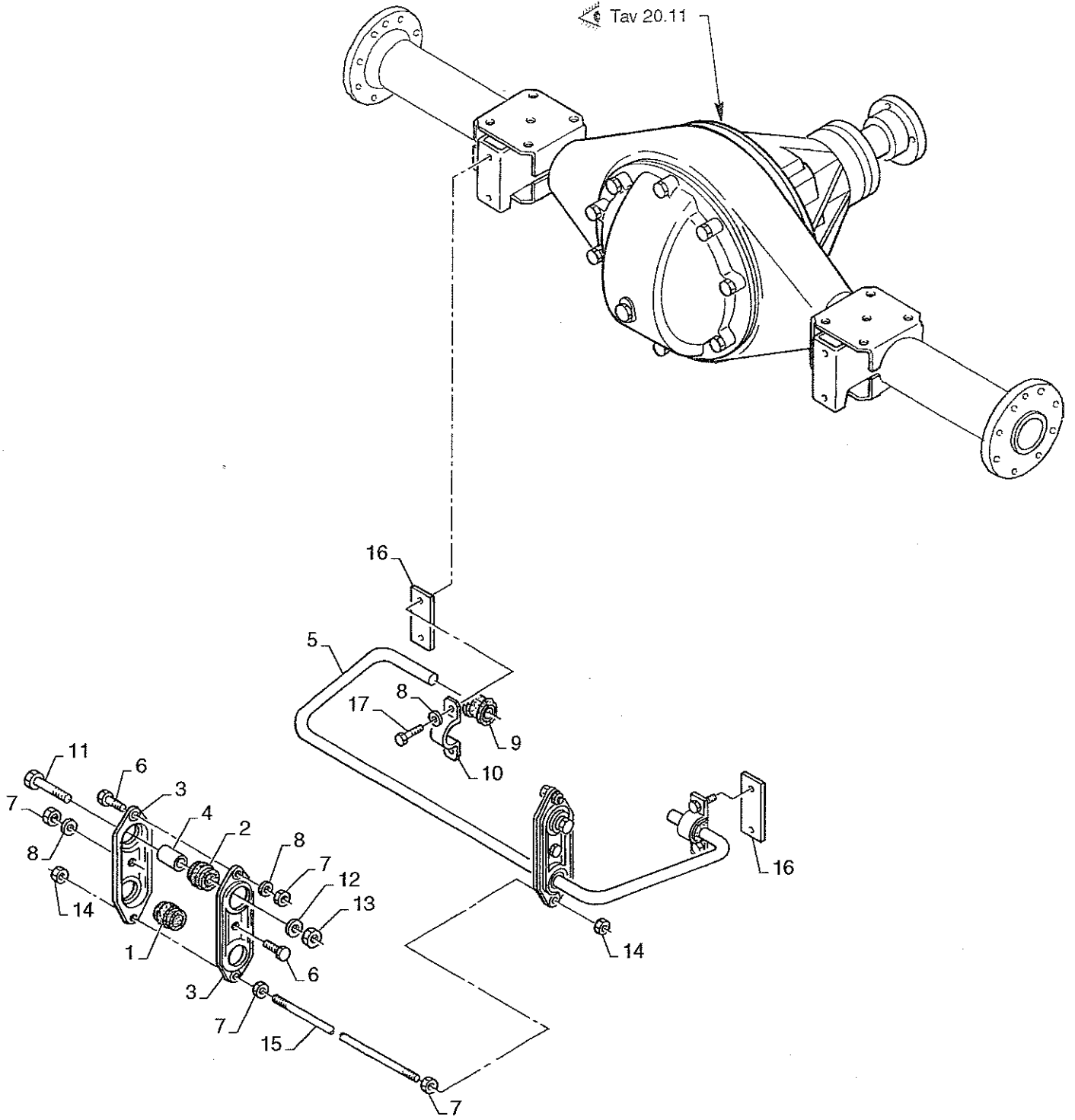

BREMACHBarra stabilizzatrice posteriore
Rear main anti-roll barTAV. **30.22**

EXTREME Ed. 04 / 2002

N. Pos.	COD.	DENOMINAZIONE	Q.ty	DESCRIPTION	Da matricola Serial number
1	B6014	Gommino barra biella	2	Rubber	200001
2	B6015	Gommino biella telaio	2	Rubber	200001
3	B6016	Semi biella	4	Malf rod	200001
4	B6017	Bussola biella	2	Bush	200001
5	92A1001	Barra di torsione	1	Torsion bear	200001
6	201040	Vite M 10x20	8	Bolt	200001
7	202005	Dado M 10	6	Nut	200001
8	203004	Rondella conica elastica	8	Washer	200001
9	B6013	Gommino barra ponte	2	Rubber	200001
10	B6012	Cavallotto barra torsione ponte	2	Rubber	200001
11	201061	Vite M 16x80	2	Bolt	200001
12	203201	Rondella 17x27x3,5	2	Washer	200001
13	202008	Dado M16	2	Nut	200001
14	202103	Dado	2	Nut	200001
15	90B1029	Perno collegamento bielle barra torsione	1	Pin	200001
16	B6028	Distanziale barra stabilizzatrice	2	Spacer	200001
17	201042	Vite M 10x30	4	Bolt	200001

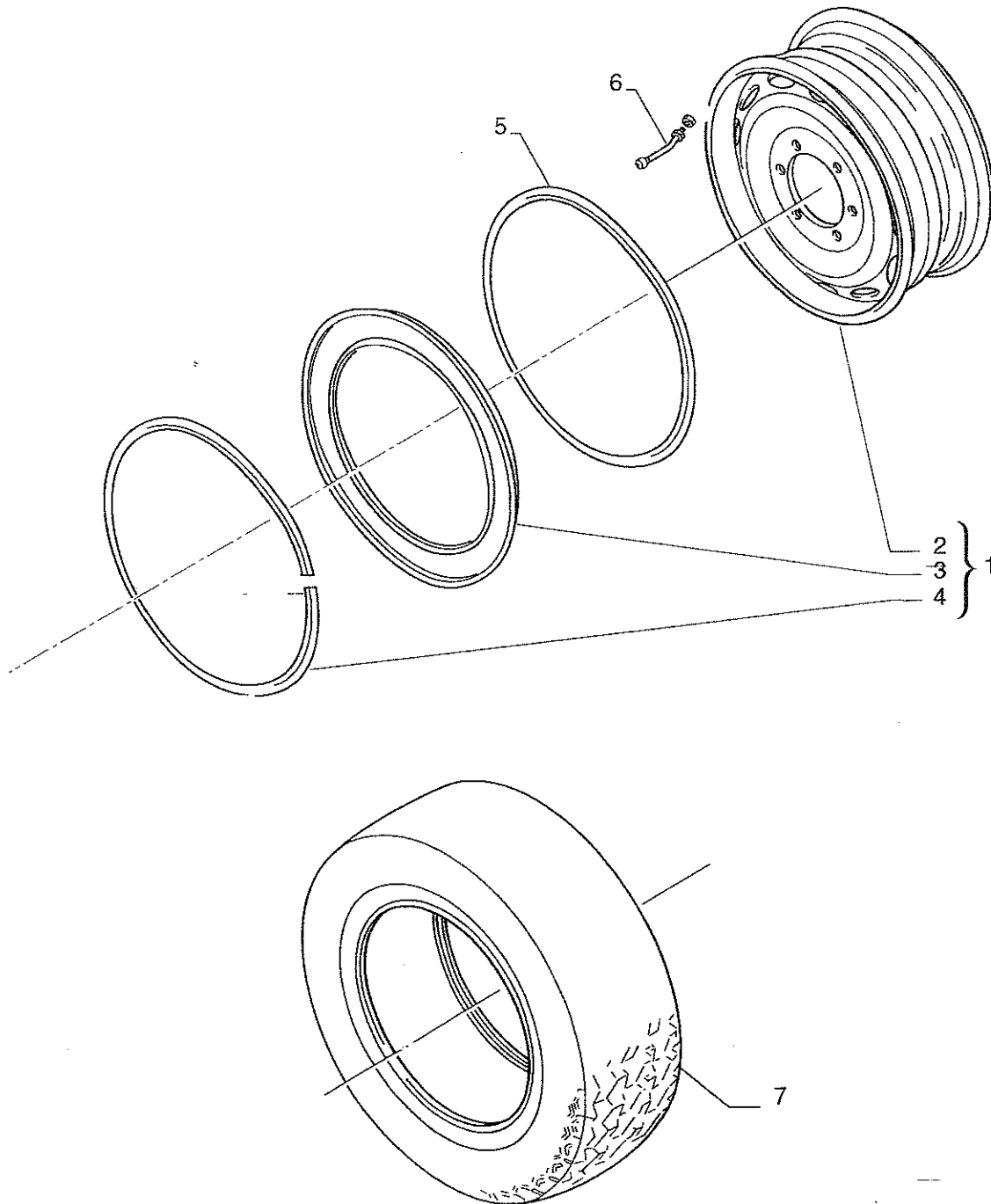

BREMACHCerchi e ruote
Rims and wheels**TAV. 30.3**

EXTREME Ed. 04 / 2002

N. Pos.	COD.	DENOMINAZIONE	Q.ty	DESCRIPTION	Da matricola Serial number
1	90C5014	Cerchione tubeless completo 16" 6,50	4	Rim	200001
2	90C5018	. Cerchio 16" 6.50	4	. Rim	200001
3	90C5016	. Anello	4	. Seal	200001
4	90C5017	. Anello tagliato	4	. Seal	200001
5	91C5002	Guarnizione cerchio 16"	4	Gasket	200001
6	91C5001	Valvola cerchio 16" 6,50	4	Valve	200001
7	90C5012	Pneumatico da 255/100 R16 XZL	4	Tyre	200001

EXTREME

**Gruppo
Group**

4 0

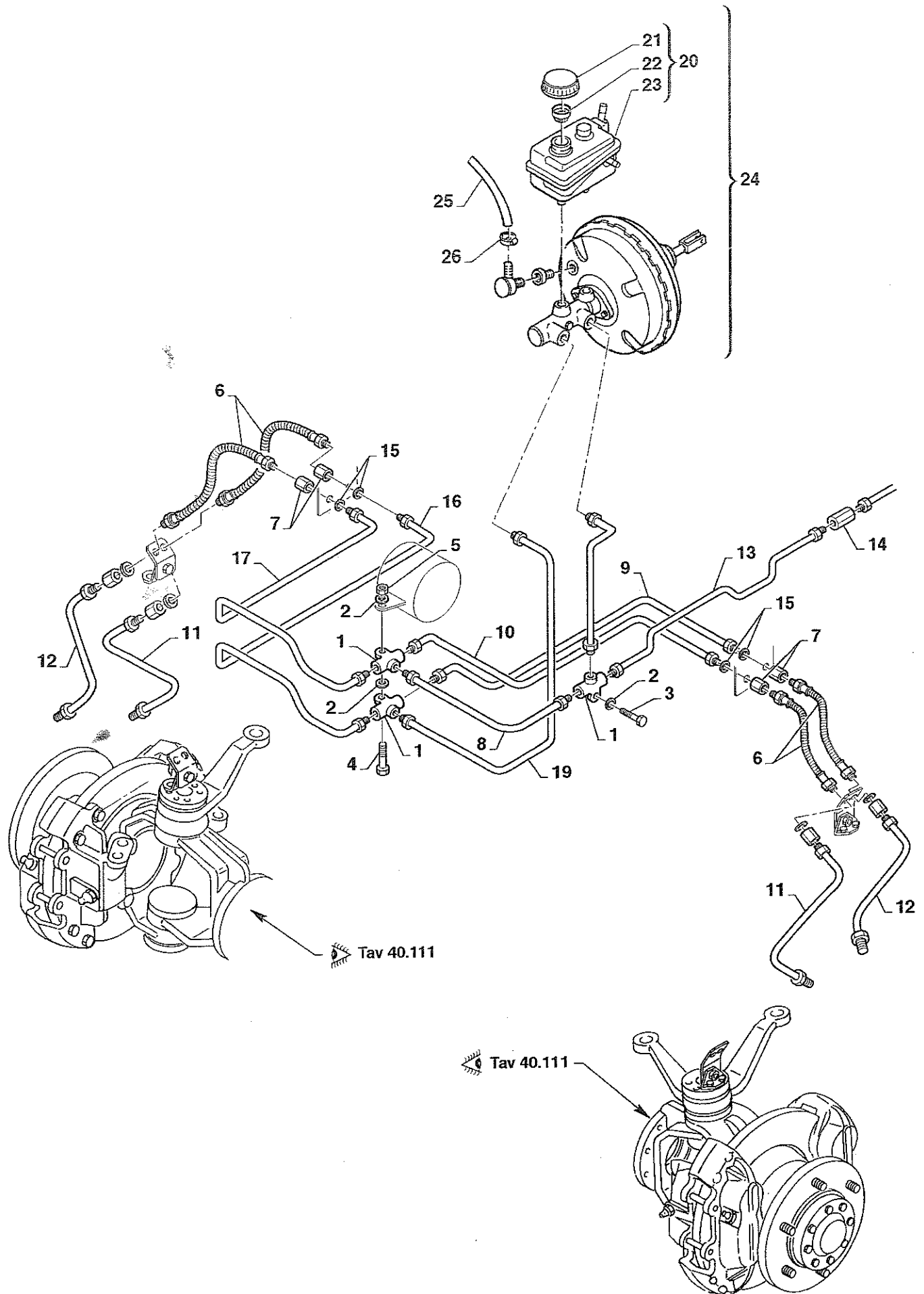

35	TUR E3					CEE					<input type="checkbox"/> YES <input type="checkbox"/> NO
----	-----------	--	--	--	--	-----	--	--	--	--	-------------------------------------------------------------

BREMACHImpianto frenante anteriore
Front braking system

TAV. 40.11

EXTREME Ed. 04/2002

N. Pos.	COD.	DENOMINAZIONE	Q.ty	DESCRIPTION	Da matricola Serial number
1	82278	Raccordo a tre vie	3	Union	200001
2	203003	Ranella elastica 8x16x1,9	2	Washer	200001
3	201022	Vite M 8x25	1	Bolt	200001
4	201027	Vite M 8x45	1	Bolt	200001
5	202004	Dado M8	1	Nut	200001
6	90F1031	Tubo flessibile freni anteriori	4	Pipe	200001
7	82269	Dado fissaggio tubo flessibile freni	4	Nut	200001
8	90F1012	Tubo freni da 3 vie laterale a 3 vie centrale sup.	1	Pipe	200001
9	90F1013	Tubo freni da pinza post. sx a 3 vie centrale inf.	1	Pipe	200001
10	90F1014	Tubo freni da pinza sx ant. a 3 vie centrale sup.	1	Pipe	200001
11	90F1032	Tubo freni da pinza destra a flessibile	2	Pipe	200001
12	90F1033	Tubo freni da pinza sinistra a flessibile	2	Pipe	200001
13	90F1009	Tubo freni manicotto 3 vie laterale	1	Pipe	200001
14	82274	Manicotto giunzione tubi freni	1	Hose	200001
15	203201	Ranella 17x27x3,5	4	Washer	200001
16	90F1015	Tubo freni da pinza post. dx a tre vie centr. inf.	1	Pipe	200001
17	90F1016	Tubo freni da pinza ant. dx a 3 vie centr. sup.	1	Pipe	200001
18	90F1010	Tubo freni da 3 vie lat. a servofreno 1° tratto	1	Pipe	200001
19	90F1011	Tubo freni da 3 vie centr. inf. a servofreno 1° tratto	1	Pipe	200001
20	G8001	Vaschetta olio completa	1	Complete oil tank	200001
21	G8002	. Tappo olio	1	. Plug	200001
22	G8003	. Filtro tappo olio	1	. Filter	200001
23	90D1015	. Vaschetta olio	1	. Oil tank	200001
24	G8000	Servofreno completo	1	Servo brake	200001
25	D8020	Tubo da depressore a servofreno	1	Pipe	200001
26	83138	Fascetta 10/18 H 8.2 per tubo servofreno	1	Clamp	200001

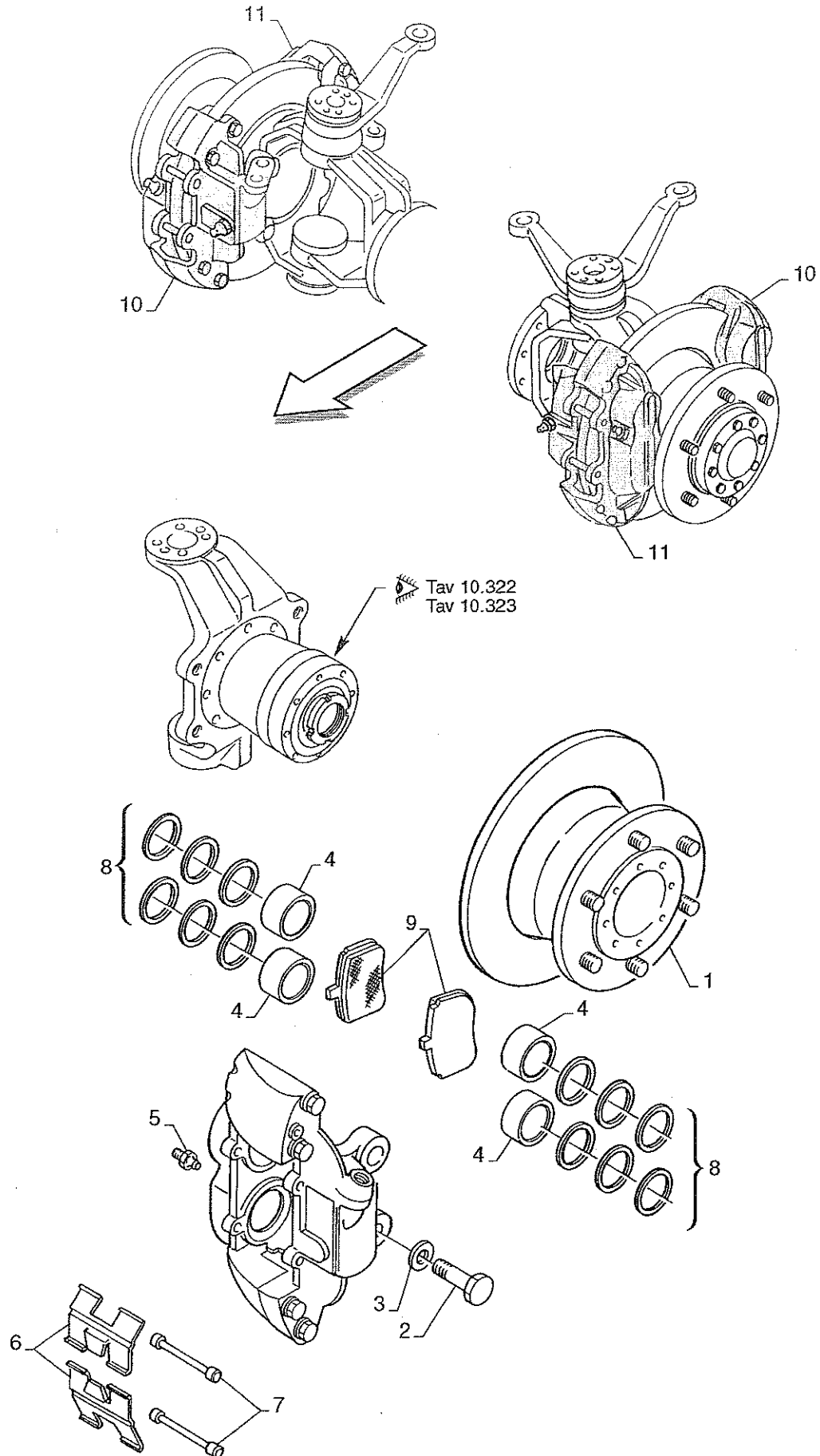

BREMACH

Freno a disco

Disk brake

TAV.40.111

EXTREME Ed. 04/2002

N. Pos.	COD.	DENOMINAZIONE	Q.ty	DESCRIPTION	Da matricola Serial number
1	92B9402	Disco freno completo	2	Complete brake disc	200001
2	B1028	Vite M 12x40x1,25	8	Bolt	200001
3	203005	Rosetta 12x24x2,8	8	Washer	200001
4	C3006	Pistoncino pinze	8	Piston	200001
5	C3005	Vite di spurgo	2	Bolt	200001
6	92F0102	Molle	4	Spring	200001
7	92F0101	Copiglia per molle	4	Cotter	200001
8	C3100	Kit guarnizioni	4	Gasket kit	200001
9	90F0912	Kit ferodi	1	Pads kit	200001
10	92F1001	Pinza freni anteriore ventilata destra	2	Caliper	200001
11	92F1002	Pinza freni anteriore ventilata sinistra	2	Caliper	200001

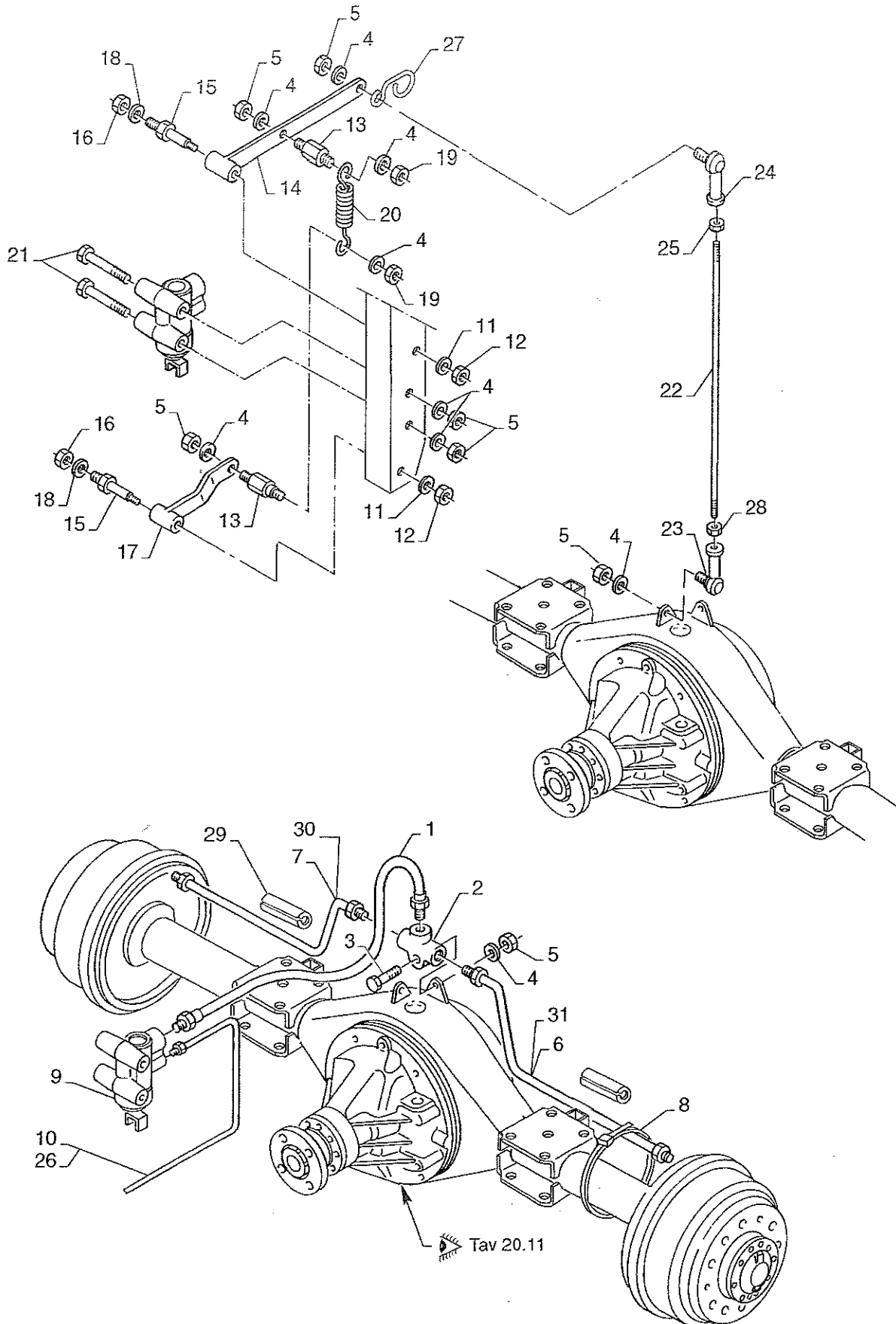

BREMACHImpianto frenante posteriore
Rear braking system**TAV. 40.12**

EXTREME Ed. 04 / 2002

N. Pos.	COD.	DENOMINAZIONE	Q.ty	DESCRIPTION	Da matricola Serial number
1	D4016	Tube flessibile freni	1	Pipe	200001
2	82278	Raccordo tre vie	1	Union	200001
3	201023	Vite M 8x30	1	Bolt	200001
4	203003	Rondella	4	Washer	200001
5	202004	Dado M8	4	Nut	200001
6	90F1043	Tube freni da 3 vie a massa frenante sinistra 35q.li	1	Pipe	200001
7	90F1044	Tube freni da 3 vie a massa frenante destra 35q.li	1	Pipe	200001
8	83629	Fascetta 338x7,6	2	Clamp	200001
9	D4013	Correttore di frenata	1	Braking force regulator	200001
10	90F1008	Tube freni da correttore frenata passo 2600	1	Pipe	200001
11	203004	Rondella elastica 10x20x2,3	2	Washer	200001
12	202005	Dado M10	2	Nut	200001
13	90F1003	Perno molla correttore di frenata	2	Pin	200001
14	90F1004	Leva superiore correttore di frenata	1	Lever	200001
15	D4012	Perno correttore	2	Pin	200001
16	202101	Dado M6 autobloccante	2	Self-locking nut	200001
17	90F1005	Leva inferiore correttore	1	Lever	200001
18	203002	Rondella elastica 6x18	2	Washer	200001
19	202102	Dado M8 autobloccante	2	Self-locking nut	200001
20	90F1001	Molla correttore di frenata	1	Spring	200001
21	201031	Vite M 8x70	2	Bolt	200001
22	90F1002	Asta leverismo correttore di frenata	1	Rod	200001
23	83573	Snodo IKO destro	1	Joint RH	200001
24	83574	Snodo IKO sinistro	1	Joint LH	200001
25	83372	Dado M8 sinistro	1	Nut	200001
26	90F1017	Tube freni da correttore frenata passo 3000	1	Pipe	200001
27	83387	Molletta per sostegno cavi	1	Spring	200001
28	202012	Dado M8 UNI 5588-65	1	Nut	200001
29	60201	Gommino di protezione per tubo freni	2	Rubber	200001
30	90F1041	Tube freni da 3 vie a massa frenante sinistra 50q.li	1	Pipe	200001
31	90F1042	Tube freni da 3 vie a massa frenante destra 50q.li	1	Pipe	200001

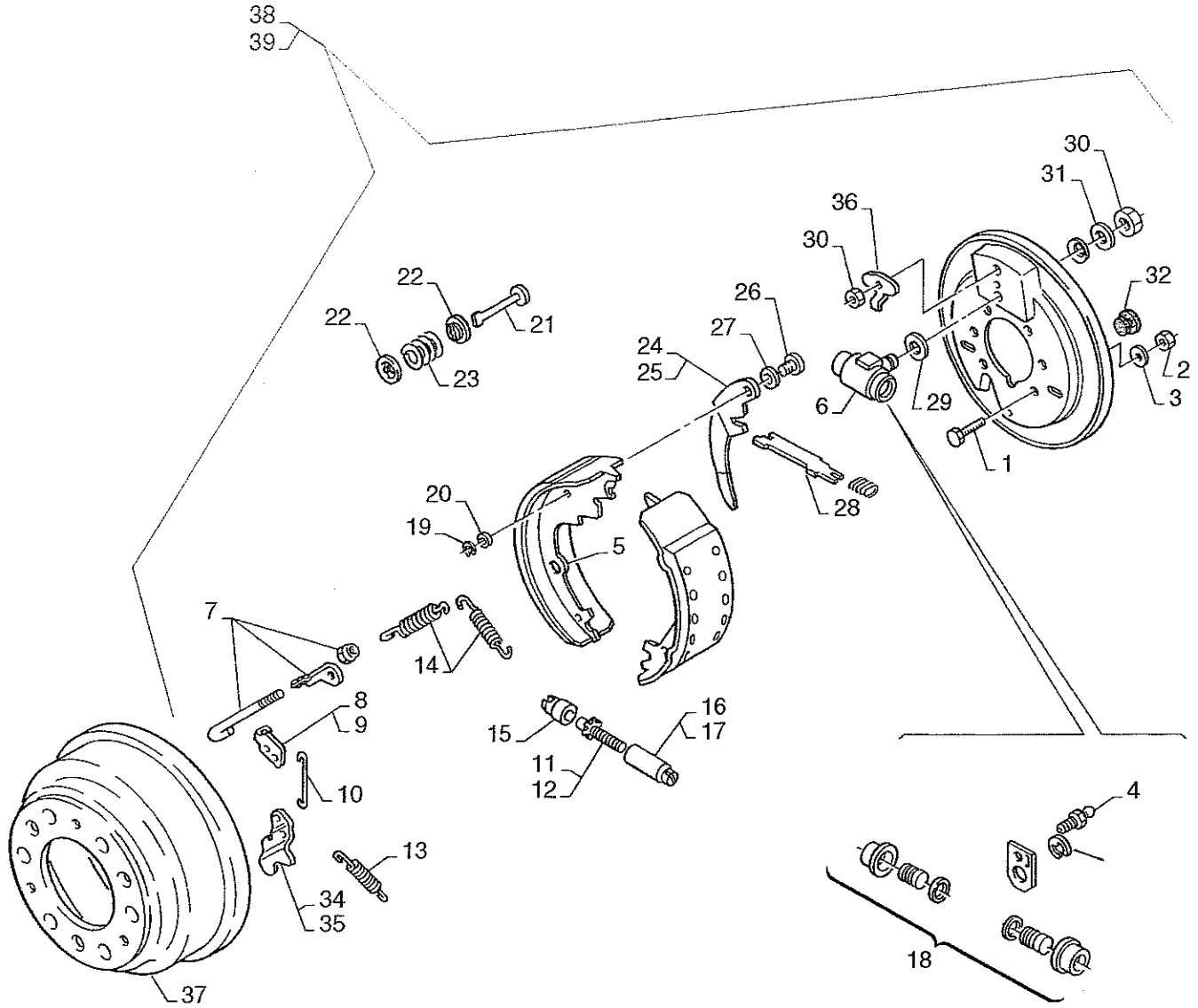

N. Pos.	COD.	DENOMINAZIONE	Q.ty	DESCRIPTION	Da matricola Serial number
1	201039	Vite M 10x35	6	Bolt	200001
2	202103	Dado M10 autobloccante	6	Self-locking nut	200001
3	203004	Rondella 10x20x2,3	6	Washer	200001
4	C1037	Vite spurgo M 7x1	1	Bolt	200001
5	C1054	Kit ferodi	1	Pads kit	200001
6	92F0107	Cilindro e vite spurgo freni	1	Cylinder	200001
7	C1055	Tirante per molla ferodi	2	Tie rod	200001
8	92F0108D	Tirante destro tamburo freni	1	Tie rod	200001
9	92F0108S	Tirante sinistro tamburo freni	1	Tie rod	200001
10	C1029	Astina	2	Rod	200001
11	C1010	Vite regolazione destra	1	Bolt	200001
12	C1011	Vite regolazione sinistra	1	Bolt	200001
13	C1017	Molla 3124-253	1	Spring	200001
14	C1016	Molla	2	Spring	200001
15	C1014	Vite regolazione ganasce	1	Bolt	200001
16	C1012	Dado regolazione ganasce destro	1	Nut	200001
17	C1013	Dado regolazione ganasce sinistro	1	Nut	200001
18	C1039	Valvole spurgo freni	1	Valve	200001
19	C1009	Anello di fermo	1	Seal	200001
20	C1007	Rondella	1	Washer	200001
21	C1020	Perno ceppo freni	1	Pin	200001
22	C1021	Disco per molla	2	Disc	200001
23	C1019	Molla	1	Spring	200001
24	C1003	Leva destra	1	Lever RH	200001
25	C1004	Leva sinistra	1	Lever LH	200001
26	C1005	Perno	1	Pin	200001
27	C1006	Molla a tazza	1	Spring	200001
28	C1008	Leva trasversale	1	Lever	200001
29	C1023	Guarnizione	1	Gasket	200001
30	C1022	Dado autobloccante 3541-220	1	Self-locking nut	200001
31	C1015	Rondella 3512-283	1	Washer	200001
32	C1025	Tappo in gomma	1	Plug	200001
33	C1026	Molla	1	Spring	200001
34	C1027	Piatto di regolazione destro	1	Plate RH	200001
35	C1028	Piatto di regolazione sinistro	1	Plate LH	200001
36	C1018	Squadretta	1	Braket	200001
37	90A4004	Tamburo	1	Drum	200001
38	92F1003	Massa frenante dx (escluso tamburo)	1	Brake mass without drum	200001
39	92F1004	Massa frenante sx (escluso tamburo)	1	Brake mass Without drum	200001

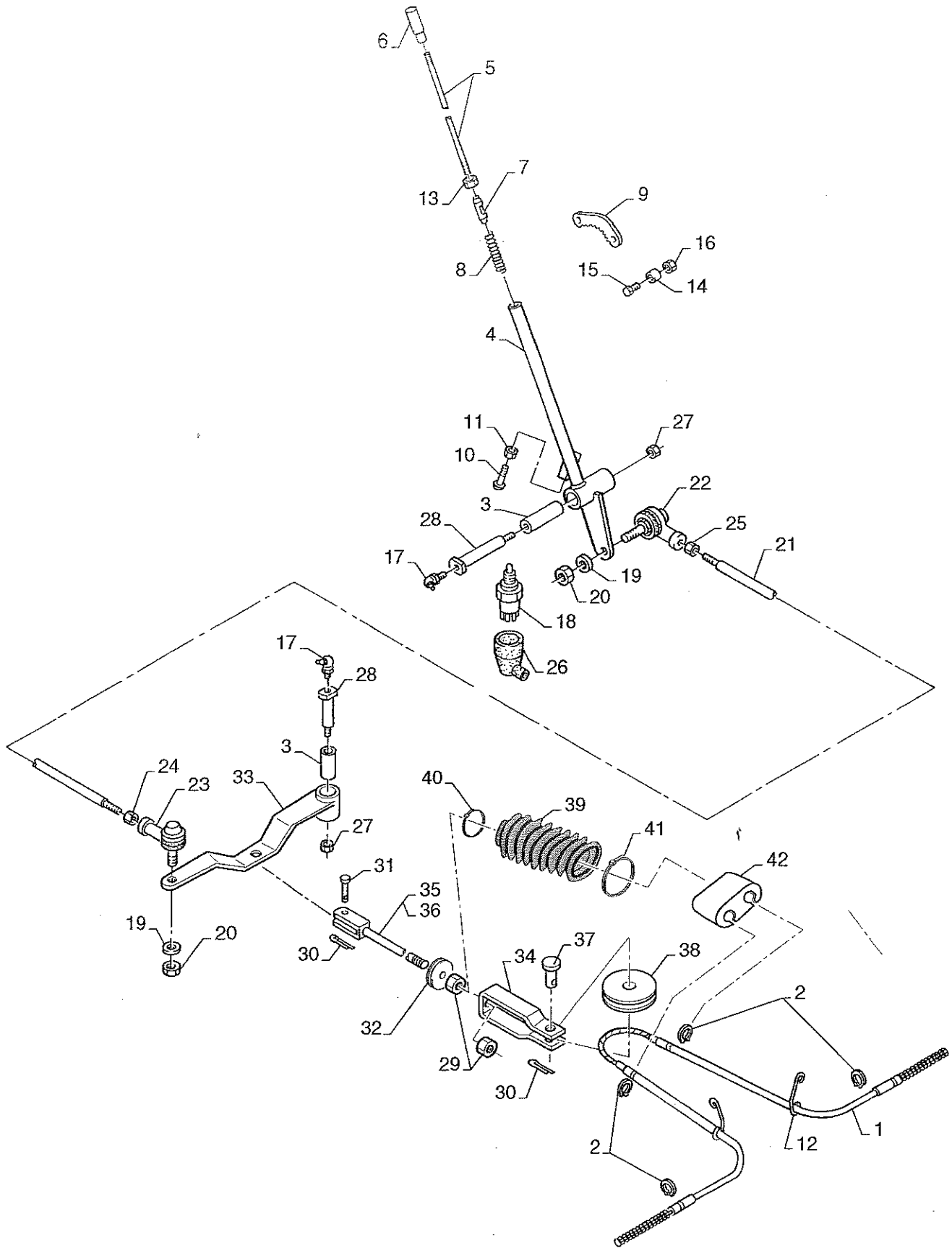

BREMACHTiranteria freno a mano
Parking brake linkage**TAV. 40.21**

EXTREME Ed. 04/2002

N. Pos.	COD.	DENOMINAZIONE	Q.ty	DESCRIPTION	Da matricola Serial number
1	90L4006	Cavo comando freno a mano ø 3,5	1	Cable	200001
2	D4008	Seeger E 8 UNI 7434	4	Seeger	200001
3	80935	Boccola 16x21x60	2	Bushing	200001
4	D4001	Leva freno a mano	1	Lever	200001
5	D4002	Asta comando di sgancio freno a mano	1	Rod	200001
6	83558	Bottono di sgancio	1	Button	200001
7	83560	Salterello	1	Pawl	200001
8	83559	Molla di richiamo	1	Spring	200001
9	83561	Settore dentato	2	Cogged sector	200001
10	201601	Vite M 6x26	1	Bolt	200001
11	202003	Dado M6	1	Nut	200001
12	83387	Passa cavo	2	Cable support	200001
13	202002	Dado M5	1	Nut	200001
14	D4003	Tassello fissaggio settore dentato	2	Bush	200001
15	201015	Vite montaggio settore dentato M 6x30	2	Bolt	200001
16	202101	Dado M6 autobloccante	2	Nut	200001
17	D4032	Ingrassatore	2	Fitting	200001
18	F3011	Microinterruttore	1	Microswitch	200001
19	203003	Rondella elastica 8x16x1,9	2	Washer	200001
20	202004	Dado M8 UNI 5587-68	2	Nut	200001
21	90L4004	Asta di rinvio comando freno a mano	1	Rod	200001
22	83573	Snodo destro IKO per collegamento asta rinvio	1	Joint RH	200001
23	83574	Snodo sinistro IKO per collegamento asta rinvio	1	Joint LH	200001
24	83372	Dado M8 sinistro per collegamento asta rinvio	1	Nut	200001
25	202012	Dado M8 UNI 5588-65	1	Nut	200001
26	F3012	Pipetta protezione microinterruttore	1	Pipette	200001
27	202103	Dado M10 autobloccante UNI 7473	1	Self-locking nut	200001
28	80943	Spinotto ND3 L88	2	Pin	200001
29	202005	Dado M10 UNI 5587-68	2	Nut	200001
30	205001	Copiglia 2x20 UNI 1336A	2	Cotter	200001
31	81535	Perno forcella asta comando	1	Pin	200001
32	90L4009	Anello di nylon	1	Seal	200001
33	90L4003	Leva rinvio	1	Lever	200001
34	92L4014	Staffa per carrucola tirante	1	Bracket	200001
35	92L4015	Tirante per versione passo 2600	1	Tie rod	200001
36	92L4016	Tirante per versione passo 3000	1	Tie rod	200001
37	92L4012	Perno carrucola tirante	1	Pin	200001
38	92L4011	Carrucola	1	Pulley	200001
39	90L4010	Cuffia rinvio freno a mano	1	Boot	200001
40	I1007	Fascetta per anello cuffia	1	Clamp	200001
41	90I1067	Fascetta per supporto cuffia	1	Clamp	200001
42	90L4008	Supporto per cuffia	1	Support	200001

EXTREME

**Gruppo
Group**

50

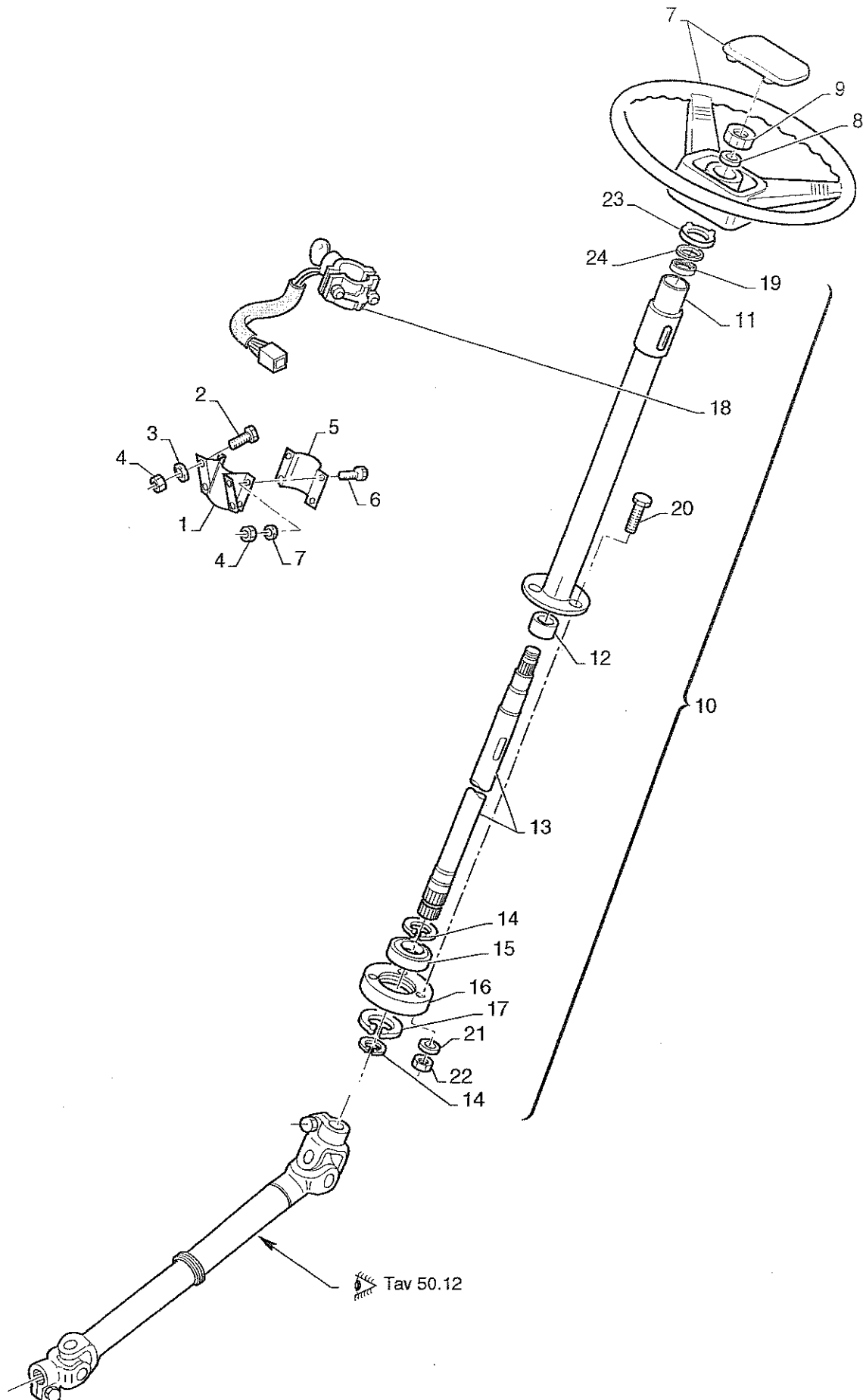

Tav 50.12

BREMACHVolante e comandi
Steering colon and driving controlsTAV. **50.11**
EXTREME Ed. 04 / 2002

N. Pos.	COD.	DENOMINAZIONE	Q.ty	DESCRIPTION	Da matricola Serial number
1	E4024	Supporto sterzo	1	Steering support	200001
2	201011	Vite M 6x16 UNI 5739-65 per supporto sterzo	4	Bolt	200001
3	203002	Rondella elastica 6x18x1,6 UNI 8836	4	Washer	200001
4	202003	Dado M6 UNI 5587-68	11	Nut	200001
5	E4025	Supporto sterzo semiguscio di chiusura	1	Steering support	200001
6	201012	Vite M 6x20 UNI 5739	4	Bolt	200001
7	E4013	Volante completo di tappo	1	Complete steering colon	200001
8	80742	Rondella 20,2x34x2,5	1	Washer	200001
9	81110	Dado ø 18 per collegamento volante piantone	1	Nut	200001
10	90D9116	Piantone sterzo completo	1	Complete steering column	200001
11	90D1046	. Canotto sterzo	1	. Steering column	200001
12	90D1044	. Anello interno per cuscinetto a rullini	1	. Seal	200001
13	90D1047	. Piantone sterzo	1	. Steering column	200001
14	E4023	. Seeger esterno UNI 7435	2	. Seeger	200001
15	E4022	. Cuscinetto canotto sterzo	1	. Bearing	200001
16	E4021	. Supporto cuscinetto canotto sterzo	1	. Support	200001
17	83023	. Seeger interno I 48 UNI 7437-75	1	. Seeger	200001
18	90I1043	. Accensione/bloccasterzo	1	. Switch on ant steering lock	200001
19	90D1043	. Cuscinetto a rullini per canotto sterzo	1	. Bearing	200001
20	201013	. Vite M 6x35 UNI 5737-65	3	. Bolt	200001
21	203001	. Rondella elastica 6x12x1,4	7	. Washer	200001
22	202003	. Dado M6 UNI 5587-68	1	. Nut	200001
23	90D1048	. Boccola rientro devioGUIDA	1	. SEAL	200001
24	90D1045	. Disco di protezione cuscinetto a rullini	1	. disc	200001

BREMACHIdroguida / piantone sterzo
HPS / steering colonTAV. **50.12**

EXTREME Ed. 04 / 2002

N. Pos.	COD.	DENOMINAZIONE	Q.ty	DESCRIPTION	Da matricola Serial number
1	90D1049	Albero scorrevole completo	1	Shaft	200001
2	90D0102	Crociera interna	2	Internal cros	200001
3	202103	Dado M10 autobloccante	1	Self-locking nut	200001
4	201161	Vite M 10x45 UNI 5931	1	Bolt	200001

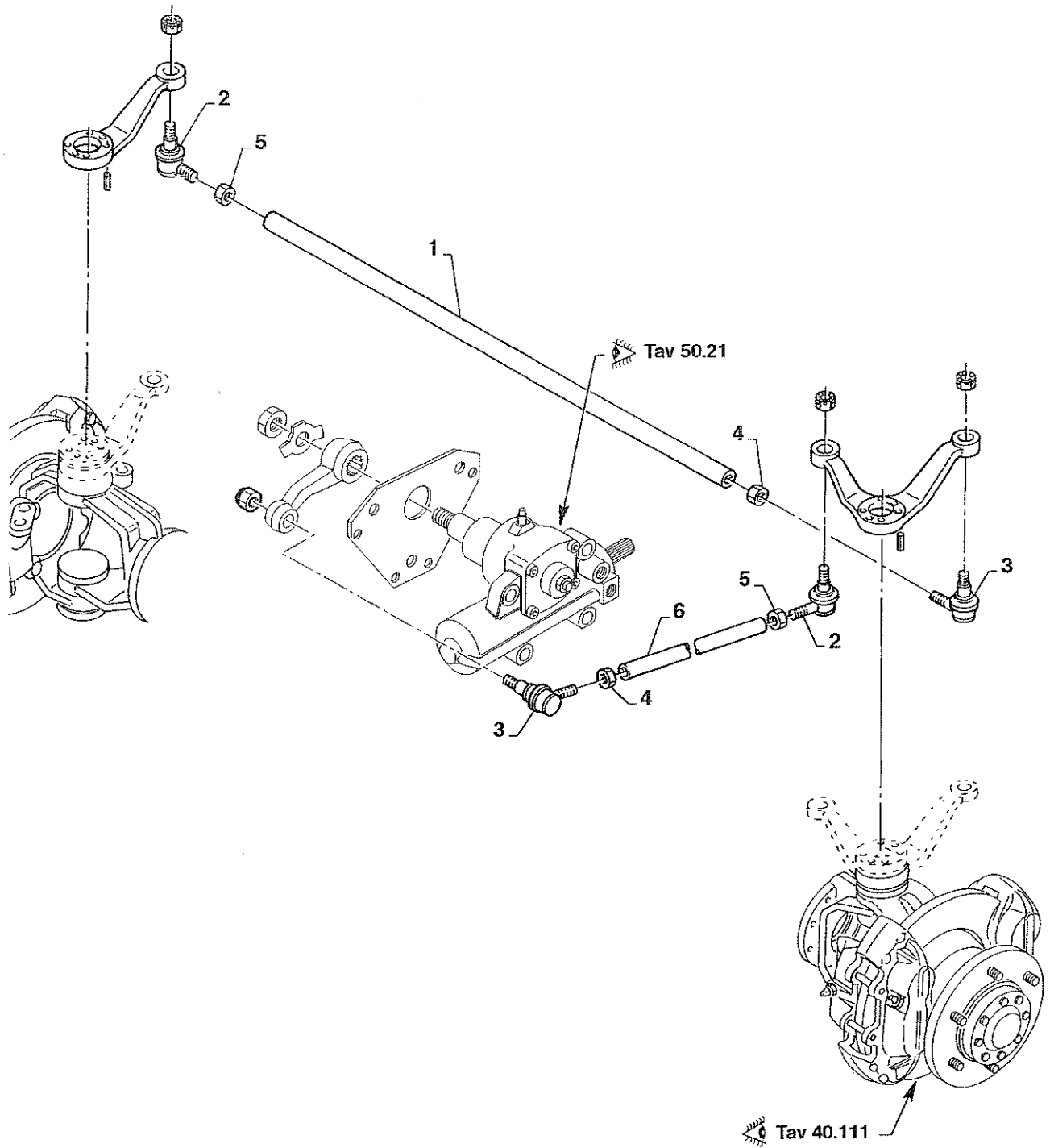

BREMACH

Idroguida/comando alle ruote

HPS / wheel control

TAV.

50.13

EXTREME Ed. 04 / 2002

N. Pos.	COD.	DENOMINAZIONE	Q.ty	DESCRIPTION	Da matricola Serial number
1	90D1003	Asta di colleg. articolazioni sterzo ai mozzi	1	Rod	200001
2	B7006	Snodo in acciaio	2	Joint	200001
3	B7007	Snodo in acciaio	2	Joint	200001
4	202203	Dado M 18x1,5 H 15 sinistro	2	Nut LH	200001
5	202204	Dado M 18x1,5 H 15 destro	2	Nut RH	200001
6	B9117	Tirante scatola sterzo asta di colleg. articolazioni	1	Tie rod	200001

BREMACHIdroguida /servoattuatore idraulico
HPS / servoactuatorTAV. **50.21**

EXTREME Ed. 04 / 2002

N. Pos.	COD.	DENOMINAZIONE	Q.ty	DESCRIPTION	Da matricola Serial number
1	90D1022	Contropiastra di supporto idroguida	1	Support plate	200001
2	90D1021	Piastra principale di supporto idroguida	1	Plate	200001
3	90D1002	Leva sterzante idroguida	1	Lever	200001
4	90D1030	Distanziale tra piastre supporto idroguida	3	Spacer	200001
5	201095	Vite M 14x1,5x130	3	Bolt	200001
6	203210	Rondella spezzata per viti M14	7	Washer	200001
7	201094	Vite M 14x1,5x50	1	Bolt	200001
8	201093	Vite M 14x1,5x25	3	Bolt	200001
9	202113	Dado M 14x1,5 autobloccante	3	Self-locking nut	200001
10	201062	Vite M 12x30	4	Bolt	200001
11	203005	Rosetta elastica 12x24x2,8	4	Washer	200001
12	202104	Dado M12 autobloccante	4	Self-locking nut	200001
13	90D1013	Idroguida TAS 15	1	Hydraulic steering unit	200001

N. Pos.	COD.	DENOMINAZIONE	Q.ty	DESCRIPTION	Da matricola Serial number
1	90D1024	Tubo olio da pompa ad attuatore sterzo	1	Pipe	200001
2	90D1050	Tubo aspirazione olio della pompa idraulica	1	Pipe	200001
3	90D1051	Tubo di ritorno olio al serbatoio	1	Pipe	200001
4	90D1017	Raccordo maschio M 16x1,5	3	Union	200001
5	90D1018	Guarnizione rame 6x21x2	7	Gasket	200001
6	90D1019	Guarnizione alluminio	1	Gasket	200001
7	90D1039	Prolunga tubo olio	1	Extension	200001
8	90D1015	Serbatoio in plastica olio per idroguida	1	Tank	200001
9	90D1027	Semi staffa	1	Bracket	200001
10	201011	Vite M 6x16	2	Bolt	200001
11	203002	Rondella elastica 6x18x1,6	8	Washer	200001
12	201012	Vite M 6x20	2	Bolt	200001
13	202003	Dado M6	2	Nut	200001
14	90D1028	Semi staffa	1	Bracket	200001
15	90H2014	Fascetta	2	Clamp	200001
16	90D1014	Pompa per idroguida	1	Pump	200001
17	B9103	Giunto	1	Joint	200001
18	A9014	Vite	1	Bolt	200001
19	203004	Rondella	1	Washer	200001

EXTREME

**Gruppo
Group**

6 0

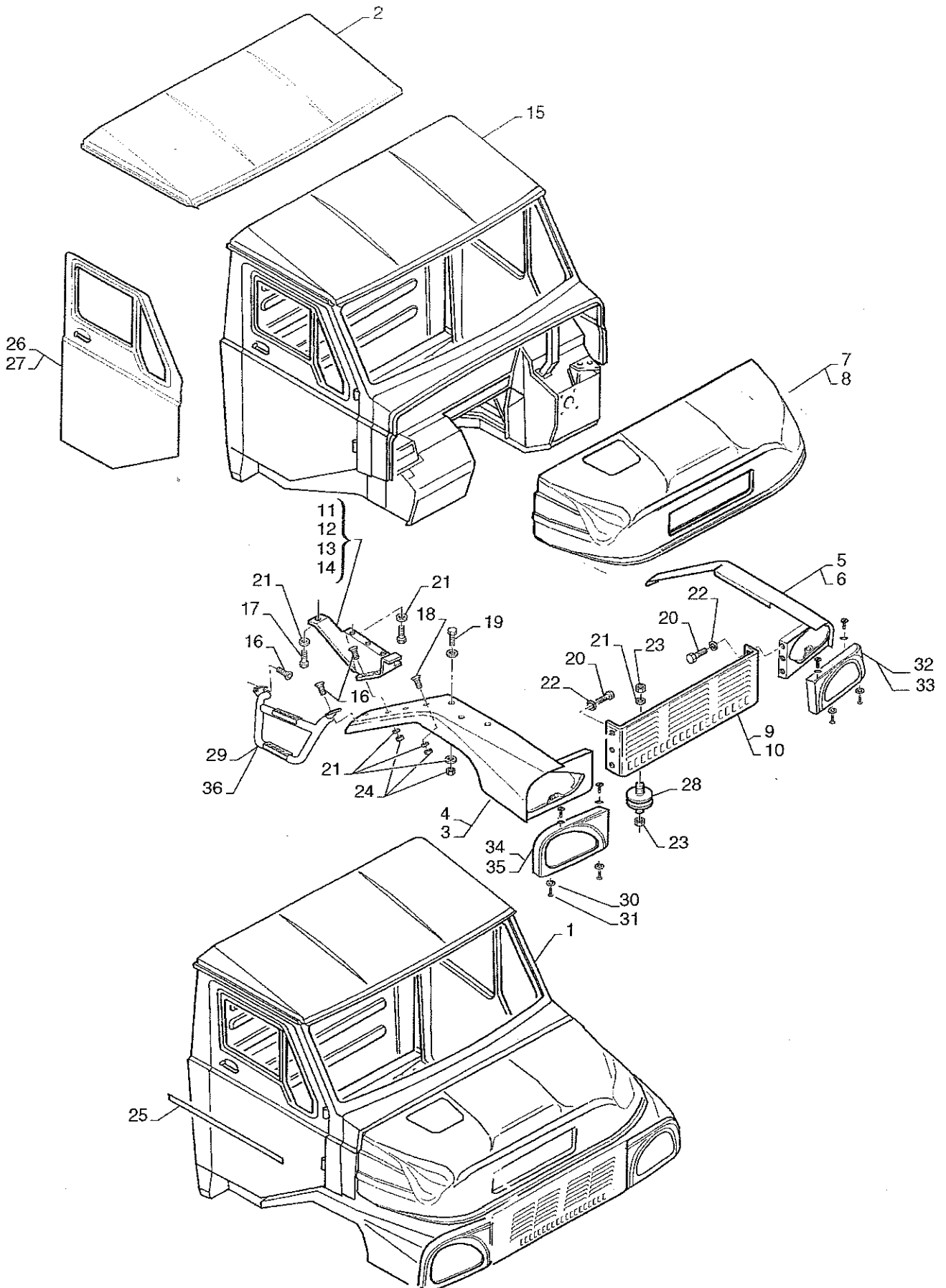

<input type="checkbox"/> 35 <input type="checkbox"/> 45	TUR <input type="checkbox"/> E3 <input type="checkbox"/>	<input type="checkbox"/> 20	<input type="checkbox"/> 4x4	<input type="checkbox"/> <input type="checkbox"/>	<input type="checkbox"/> <input type="checkbox"/>	CEE <input type="checkbox"/>	<input type="checkbox"/> <input type="checkbox"/>	<input type="checkbox"/> <input type="checkbox"/>	<input type="checkbox"/> YES <input type="checkbox"/> NO
------------------------------------------------------------	----------------------------------------------------------------	-----------------------------	------------------------------	---------------------------------------------------	---------------------------------------------------	---------------------------------	---------------------------------------------------	---------------------------------------------------	-------------------------------------------------------------

N. Pos.	COD.	DENOMINAZIONE	Q.ty	DESCRIPTION	Da matricola Serial number
1		Cabina semplice completa e verniciata	1	Full simple cab (treated by painted)	200001
2	28440	. Tetto cabina grezzo	1	. Cabin roof semy-finished	200001
3	90E1045	. Parafango anteriore destro trattato	1	. Right wing (treated)	200001
4		. Parafango anteriore destro verniciato	1	. Right wing (treated by painted)	200001
5	90E1046	. Parafango anteriore sinistro trattato	1	. Left wing (treated)	200001
6		. Parafango anteriore sinistro verniciato	1	. Left wing (treated by painted)	200001
7	90GE1079	Cofano grezzo	1	Raw bonnet	200001
8		Cofano verniciato	1	Painted bonnet	200001
9	90E1072C	Mascherina inferiore trattata	1	Grill	200001
10		Mascherina inferiore verniciata	1	Painted grill	200001
11	E4120	Supporto inferiore parafango destro	1	Right wing support	200001
12	E4120V	Supporto inferiore parafango destro verniciato	1	Right wing support (treated by painted)	200001
13	E4121	Supporto inferiore parafango sinistro	1	Left wing support	200001
14	E4121V	Supporto inferiore parafango sinistro verniciato	1	Left wing support (treated by painted)	200001
15	CATBK00000	Cabina con porte e trattamento protettivo	1	Cab	200001
16	201014	Vite M 6x25 UNI 5739-65	6	Bolt	200001
17	201011	Vite M 6x16 UNI 5739-65	6	Bolt	200001
18	201013	Vite M 6x35 UNI 5737-65	8	Bolt	200001
19	201012	Vite M 6x20 UNI 5739-65	4	Bolt	200001
20	201020	Vite M 8x16 UNI 5739-65	6	Bolt	200001
21	203002	Rondella elastica 6x18x1,6	30	Washer	200001
22	203003	Rondella elastica 8x16x1,9	6	Washer	200001
23	202003	Dado M6 UNI 5587-68	6	Nut	200001
24	202101	Dado M6 autobloccante UNI 7473	14	Self-locking nut	200001
25	E4119	Nastro decorativo adesivo	1	Ornamental tape	200001
26	90E1073C	Portiera destra cataforizzata	1	Right door (treated by cataphoresis)	200001
27	90E1076C	Portiera sinistra cataforizzata	1	Left door (treated by cataphoresis)	200001
28	E4086	Gommino	2	Rubber	200001
29	90P7037D	Pedana di salita dx	1	Right Plate	200001
30	203300	Rondella nera F15	8	Washer	200001
31	204010	Vite autofilettate 4,8x22 brunita UNI 6954	8	Bolt	200001
32	90E1049	Profilo fanale sinistro	1	Moulding left headlamp	200001
33		Profilo fanale sinistro verniciato	1	Moulding left headlamp	200001
34	90E1048	Profilo fanale destro	1	Moulding right headlamp	200001
35		Profilo fanale destro verniciato	1	Moulding right headlamp	200001
36	90P7037S	Pedana di salita sx	1	Left Plate	200001
37	90N2021	Distanziale mascherina ant.	2	Spacer	200001

Codici in bianco : da richiedere al magazzino ricambi prima di inviare l'ordine.

N. Pos.	COD.	DENOMINAZIONE	Q.ty	DESCRIPTION	Da matricola Serial number
1		Cabina doppia tre porte verniciata	1	Double cab 3-seat (painted)	200001
2	28771	.Tetto cabina grezzo	1	. Cabin roof semy-finished	200001
3	90E1045	.Parafango anteriore destro trattato	1	. Right wing (treated)	200001
4		.Parafango anteriore destro verniciato	1	. Right wing (treated by painted)	200001
5	90E1046	.Parafango anteriore sinistro trattato	1	. Left wing (treated)	200001
6		.Parafango anteriore sinistro verniciato	1	. Left wing (treated by painted)	200001
7	90GE1079	Cofano grezzo	1	Raw bonnet	200001
8		Cofano verniciato	1	Painted bonnet	200001
9	90E1072C	Mascherina inferiore trattata	1	Grill	200001
10		Mascherina inferiore verniciata	1	Painted grill	200001
11	E4120	Supporto inferiore parafango destro	1	Right wing support	200001
12	E4120V	Supporto inferiore parafango destro verniciato	1	Right wing support (treated by painted)	200001
13	E4121	Supporto inferiore parafango sinistro	1	Left wing support	200001
14	E4121V	Supporto inferiore parafango sinistro verniciato	1	Left wing support (treated by painted)	200001
15		Cabina con porte con trattamento protettivo	1	Cab	200001
16	201014	Vite M 6x25 UNI 5739-65	6	Bolt	200001
17	201011	Vite M 6x16 UNI 5739-65	12	Bolt	200001
18	201013	Vite M 6x35 UNI 5737-65	8	Bolt	200001
19	201012	Vite M 6x20 UNI 5739-65	4	Bolt	200001
20	201020	Vite M 8x16 UNI 5739-65	6	Bolt	200001
21	203002	Rondella elastica 6x18x1,6	36	Washer	200001
22	203003	Rondella elastica 8x16x1,9	10	Washer	200001
23	202003	Dado M6 UNI 5587-68	8	Nut	200001
24	202101	Dado M6 autobloccante UNI 7473	14	Self-locking nut	200001
25	E4119	Nastro decorativo adesivo	1	Ornamental tape	200001
26	90E1073C	Portiera destra cataforizzata	1	Right door (treated by cataphoresis)	200001
27	90E1076C	Portiera sinistra cataforizzata	1	Left door (treated by cataphoresis)	200001
28	E4086	Gommino	2	Rubber	200001
29	90E1080C	Portiera laterale posteriore destra cataforizzata	1	Door (treated by cataphoresis)	200001
30	201021	Vite M 8x20 UNI 5739-65	4	Bolt	200001
31	201211	Vite SPE M 8x30 UNI 5933	8	Bolt	200001
32	83984	Collegamento a pressione	2	Union	200001
33	90P0700	Zoccolo intermedio pedane	2	Intermediate foot rest support	200001
34	90P0701	Attacco posteriore pedane	2	Rear foot-rest support	200001
35	90P7037	Pedana di salita dx	1	Right Plate	200001
36	203300	Rondella nera F15	8	Washer	200001
37	204010	Vite autofilettate 4,8x22 brunite UNI 6954	8	Bolt	200001
38	90E1049	Profilo fanale sinistro	1	Moulding left headlamp	200001
39		Profilo fanale sinistro verniciato	1	Moulding left headlamp	200001
40	90E1048	Profilo fanale destro	1	Moulding right headlamp	200001
41		Profilo fanale destro verniciato	1	Moulding right headlamp	200001
42	90P7037S	Pedana di salita sx	2	Left Plate	200001
43	90N2021	Distanziale mascherina ant.	2	Spacer	200001

Codici in bianco : da richiedere al magazzino ricambi prima di inviare l'ordine.

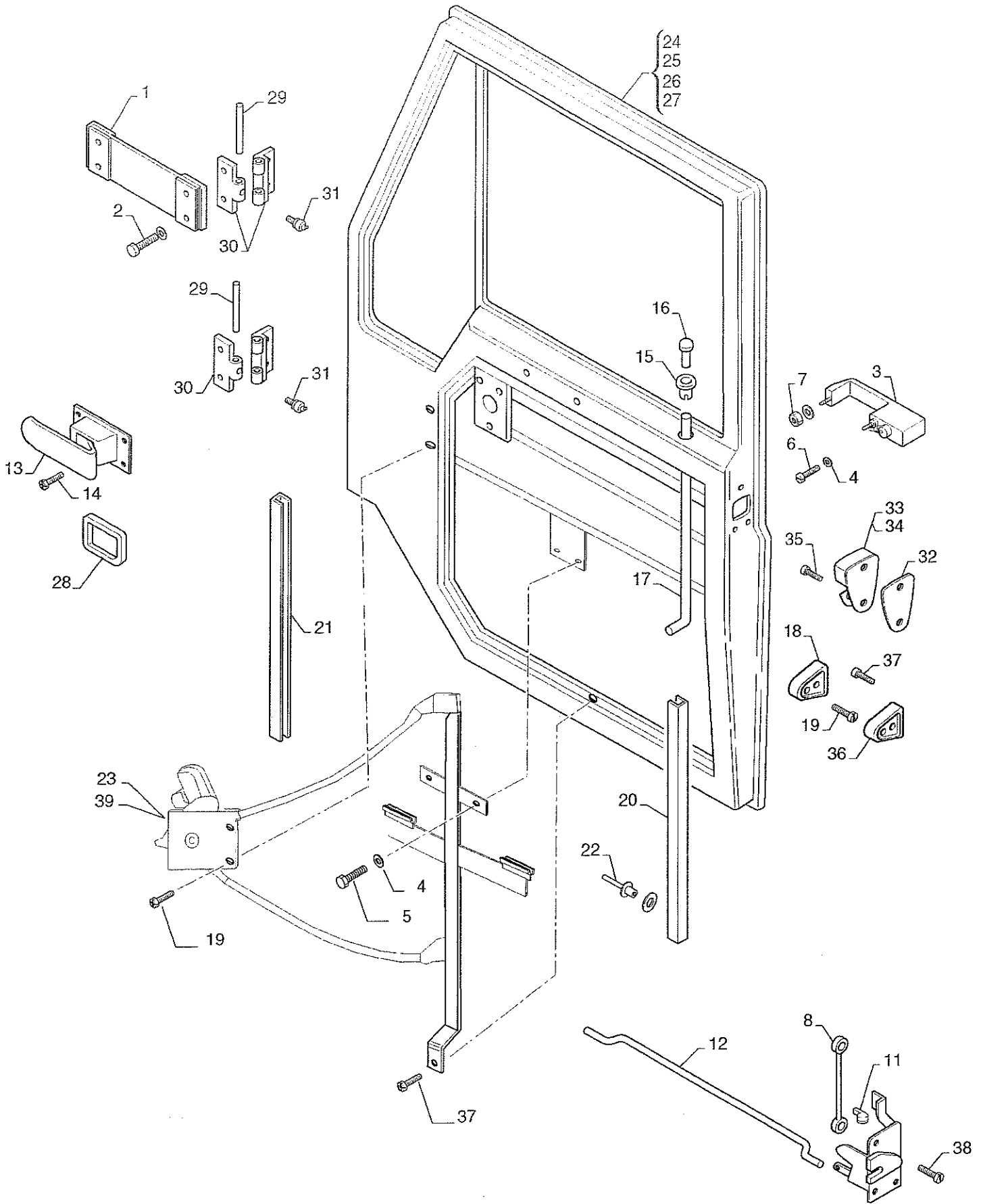

	<input type="checkbox"/> 35		<input type="checkbox"/> E3		<input type="checkbox"/> 20		<input type="checkbox"/> 4x4		<input type="checkbox"/> CEE		<input type="checkbox"/> 1		<input type="checkbox"/> 2		<input type="checkbox"/> YES		<input type="checkbox"/> NO
--	-----------------------------	--	-----------------------------	--	-----------------------------	--	------------------------------	--	------------------------------	--	----------------------------	--	----------------------------	--	------------------------------	--	-----------------------------

N. Pos.	COD.	DENOMINAZIONE	Q.ty	DESCRIPTION	Da matricola Serial number
1	90P9732	Tirante ferma porta	1	Tie rod	200001
2	201302	Vite M 5x16 inox UNI 7689	4	Bolt	200001
3	92P7003	Maniglia con chiave	1	Handle	200001
4	203001	Rondella elastica 6x12x1,4	3	Washer	200001
5	201010	Vite M 6x10 UNI 5739-65	1	Bolt	200001
6	201011	Vite M 6x16 UNI 5739-65	1	Bolt	200001
7	202003	Dado M 6 UNI 5587-68	1	Nut	200001
8	92P7013	Tirante chiusura serratura	1	Tie rod	200001
9	92P7004D	Serratura porta destra	1	Lock RH	200001
10	92P7004S	Serratura porta sinistra	1	Lock LH	200001
11	92P7010	Giunto collegamento aste comando serratura	1	Joint	200001
12	92P7014	Tirante maniglia serratura	1	Tie rod	200001
13	92P7005	Maniglia apertura interna porta	1	Handle	200001
14	204003	Vite autofilettante testa croce 8x16 UNI 6954	2	Bolt	200001
15	92P7009	Guarnizione pomello serratura	1	Gasket	200001
16	92P7012	Pomello serratura interna	1	Knob	200001
17	90P7015	Tirante per serratura interna	1	Tie rod	200001
18	E4122	Gommino ammortizzatore chiusura porta	1	Rubber	200001
19	201213	Vite M 6x25 UNI 5933	2	Bolt	200001
20	90P7018D	Guida verticale vetro	1	Guide	200001
21	90P7018S	Guida verticale	1	Guide	200001
22	83545	Rivetto 4x10 per montaggio guide verticali	2	Rivet	200001
23	90P7046D	Alzacristalli portiera destra	1	Winow winder	200001
24	90E1073C	Portiera trattata destra	1	Right door (treated by cataphoresis)	200001
25	90E1076C	Portiera trattata sinistra	1	Left door (treated by cataphoresis)	200001
26		Portiera verniciata destra	1	Right door (treated by painted)	200001
27		Portiera verniciata sinistra	1	Left door (treated by painted)	200001
28	92P7006	Protezione maniglia apri porta interna	1	Protection	200001
29	92P7001	Perno ingrassabile per cerniera porta 8x65	2	Pin	200001
30	E4071	Cerniera	1	Hinge	200001
31	D4032	Ingrassatore a 'L'	2	Fitting	200001
32	90P7016	Spessore riscontro portiera	1	Shim	200001
33	92P7007D	Riscontro per portiera destra	1	Striker	200001
34	92P7007S	Riscontro per portiera sinistra	1	Striker	200001
35	201421	Vite M 8x40 UNI 7688	2	Bolt	200001
36	GE4124	Riscontro portiera	1	Striker	200001
37	201214	Vite M 6x10 UNI 5933	2	Bolt	200001
38	201301	Vite M 6x16 inox UNI 7689	3	Bolt	200001
39	90P7046S	Alzacristalli portiera sinistra	1	Winow winder	200001

Codici in bianco : da richiedere al magazzino ricambi prima di inviare l'ordine.

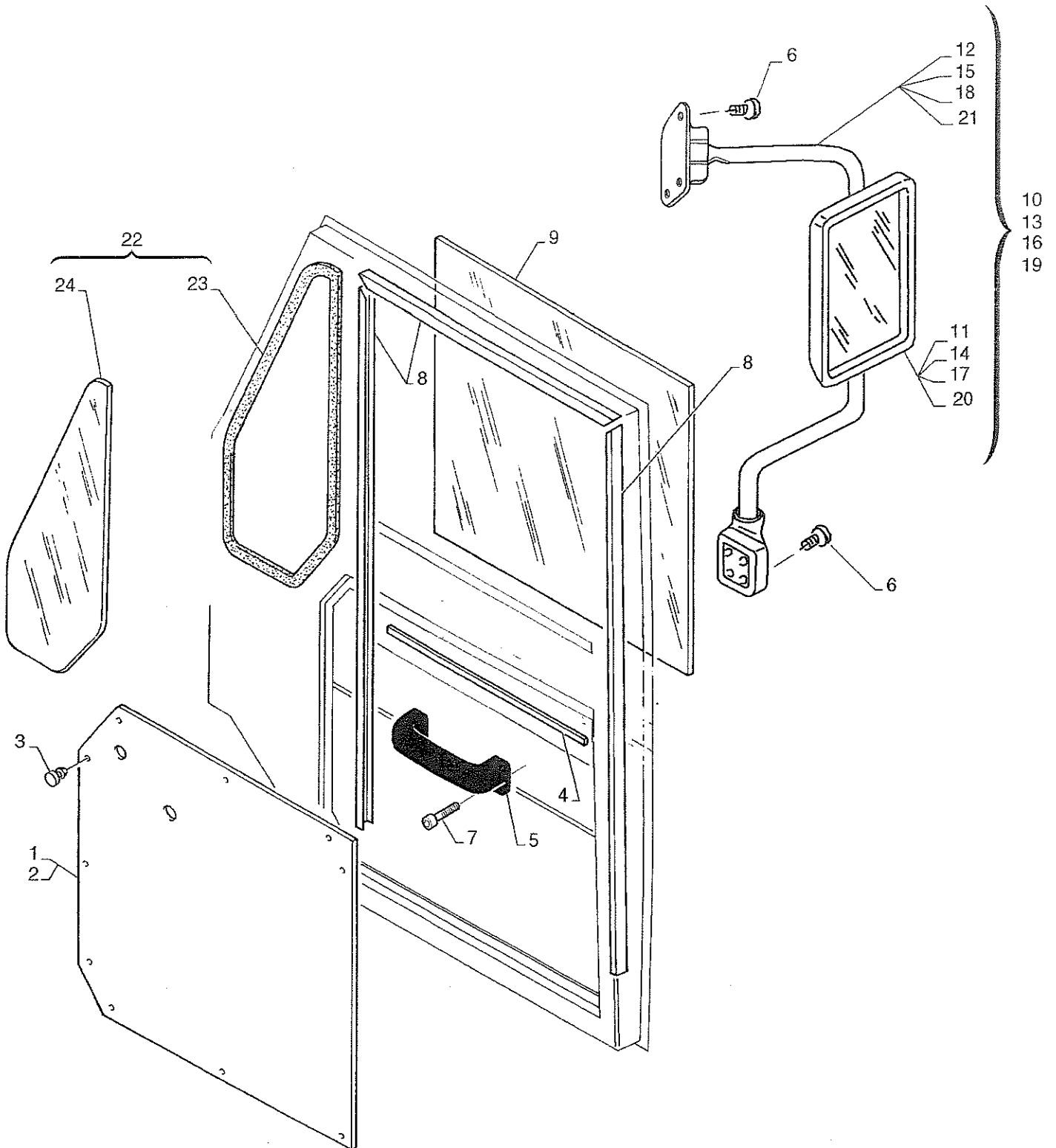

<input type="checkbox"/> 35 <input type="checkbox"/> 45	TUR <input type="checkbox"/> E3	20	4x4	<input type="checkbox"/> <input type="checkbox"/>	<input type="checkbox"/> <input type="checkbox"/>	CEE <input type="checkbox"/>	<input type="checkbox"/> <input type="checkbox"/>	<input type="checkbox"/> <input type="checkbox"/>	<input type="checkbox"/> YES <input type="checkbox"/> NO
------------------------------------------------------------	------------------------------------	----	-----	---------------------------------------------------	---------------------------------------------------	---------------------------------	---------------------------------------------------	---------------------------------------------------	-------------------------------------------------------------

BREMACHVetri e guarnizioni per portiera
Windows and door weather strips**TAV.60.132**

EXTREME Ed. 04 / 2002

N. Pos.	COD.	DENOMINAZIONE	Q.ty	DESCRIPTION	Da matricola Serial number
1	90P7049D	Rivestimento portiera destra	1	Cover	200001
2	90P7049S	Rivestimento portiera sinistra	1	Cover	200001
3	83984	Collegamento a pressione per mont. rivest. portiera	15	Connection	200001
4	E4061	Guarnizione raschia polvere vetro scorrevole	1	Gasket	200001
5	92P7017	Maniglia tira porta	1	Handle	200001
6	201305	Vite M 6x20 UNI 7689 INOX	7	Bolt	200001
7	201213	Vite M 6x25 UNI 5933 per mont. man. tira porta	2	Bolt	200001
8	E4060	Guarnizione girovetro laterale	1	Guide	200001
9	90P1028	Vetro scorrevole	1	Glass	200001
10	90P1037D	Assieme specchio retrov. est. dx(car.1800)	1	Mirror	200001
11	90P0101	. Specchio	1	. Glass	200001
12	90P0102D	. Braccio destro	1	. Arm	200001
13	90P1037S	Assieme specchio retrov. est. sx(car.1800)	1	Mirror	200001
14	90P0101	. Specchio	1	. Glass	200001
15	90P0102S	. Braccio sinistro	1	. Arm	200001
16	90P1041D	Assieme specchio retrov. est. dx(car.1900)	1	Mirror	200001
17	90P0101	. Specchio	1	. Glass	200001
18	90P0103D	. Braccio largo destro	1	. Arm	200001
19	90P1041S	Assieme specchio retrov. est. sx(car.1900)	1	Mirror	200001
20	90P0101	. Specchio	1	. Glass	200001
21	90P0103S	. Braccio largo sinistro	1	. Arm	200001

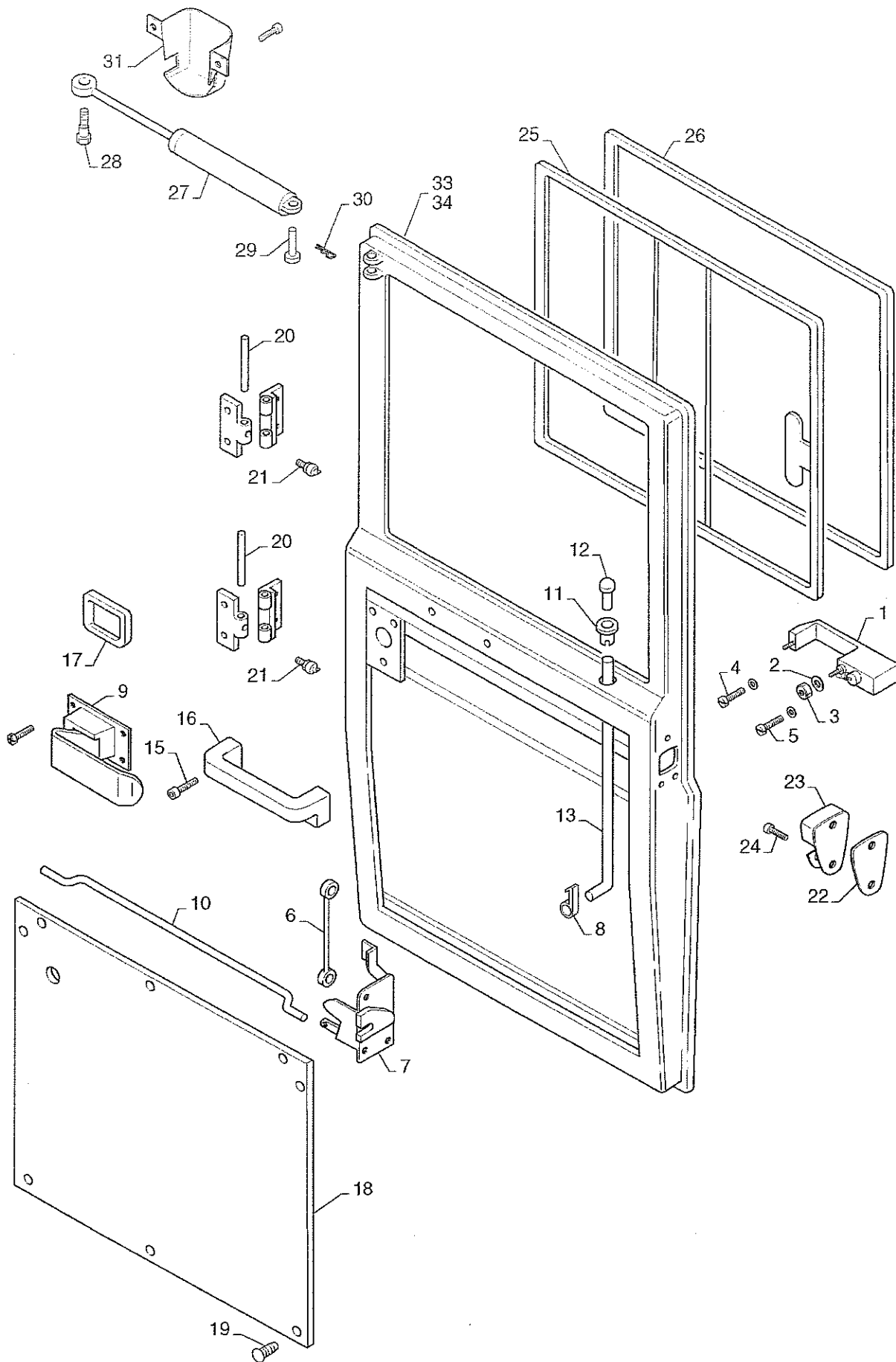

<input type="checkbox"/> 35	<input type="checkbox"/> E3	<input type="checkbox"/> 20	<input type="checkbox"/> 4x4	<input type="checkbox"/> 1	<input type="checkbox"/> CEE	<input type="checkbox"/> 2	<input type="checkbox"/> 3	<input type="checkbox"/> YES	<input type="checkbox"/> NO
-----------------------------	-----------------------------	-----------------------------	------------------------------	----------------------------	------------------------------	----------------------------	----------------------------	------------------------------	-----------------------------

BREMACHPortiera laterale DX
Right side door**TAV. 60.141**

EXTREME Ed. 04 / 2002

N. Pos.	COD.	DENOMINAZIONE	Q.ty	DESCRIPTION	Da matricola Serial number
1	92P7003	Maniglia con chiave	1	Handle	200001
2	203001	Rondella elastica 6x12x1,4	3	Washer	200001
3	202003	Dado M 6 UNI 5587-68	1	Nut	200001
4	201010	Vite M 6x10 UNI 5739-65	1	Bolt	200001
5	201011	Vite M 6x16 UNI 5739-65	1	Bolt	200001
6	92P7013	Tirante chiusura serratura	1	Tie rod	200001
7	92P7004D	Serratura porta destra	1	Lock	200001
8	92P7010	Giunto collegamento aste comando serratura	1	Joint	200001
9	92P7005	Maniglia apriporta interna	1	Handle	200001
10	90P7024	Tirante apertura porta laterale	1	Tie rod	200001
11	92P7009	Guarnizione pomello serratura	1	Gasket	200001
12	92P7012	Pomello comando interno sicura	1	Knob	200001
13	90P7045	Tirante sicura	1	Tie rod	200001
15	201213	Vite speciale M 6x25 UNI 5933	2	Bolt	200001
16	92P7017	Maniglia tira porta	1	Handle	200001
17	92P7006	Protezione maniglia apri porta interna	1	Protection	200001
18	E4129	Pannello rivestimento portiera	1	Panel	200001
19	83984	Collegam. a pressione per mont. rivestim. portiera	12	Connection	200001
20	92P7001	Perno ingrassabile per cerniera porta 8x65	2	Pin	200001
21	D4032	Ingrassatore a 'L'	2	Fitting	200001
22	90P7016	Spessore riscontro portiera	1	Shim	200001
23	92P7007D	Riscontro portiera	1	Striker	200001
24	201421	Vite M 8x40 UNI 7688 per montaggio riscontro	1	Bolt	200001
25	ED4127	Vetro laterale scorrevole per porta posteriore dx	1	Glass	200001
26	E4128	Guarnizione vetro laterale scorrevole	1	Gasket	200001
27	K2075	Molla a gas	1	Spring	200001
28	K2085	Perno montaggio molla a gas - lato cabina	1	Pin	200001
29	81535	Perno montaggio molla a gas - lato portiera	1	Pin	200001
30	205001	Copiglia 2x20 UNI 1336A	1	Cotter	200001
31	K2156	Protezione pistone molla a gas	1	Protection	200001
32	204005	Vite autofilettante	1	Bolt	200001
33	90E1080C	Portiera trattata laterale destra	1	Lateral left door (treated by cataphoresis)	200001
34		Portiera verniciata laterale destra	1	Lateral right door (treated by painted)	200001

Codici in bianco : da richiedere al magazzino ricambi prima di inviare l'ordine.

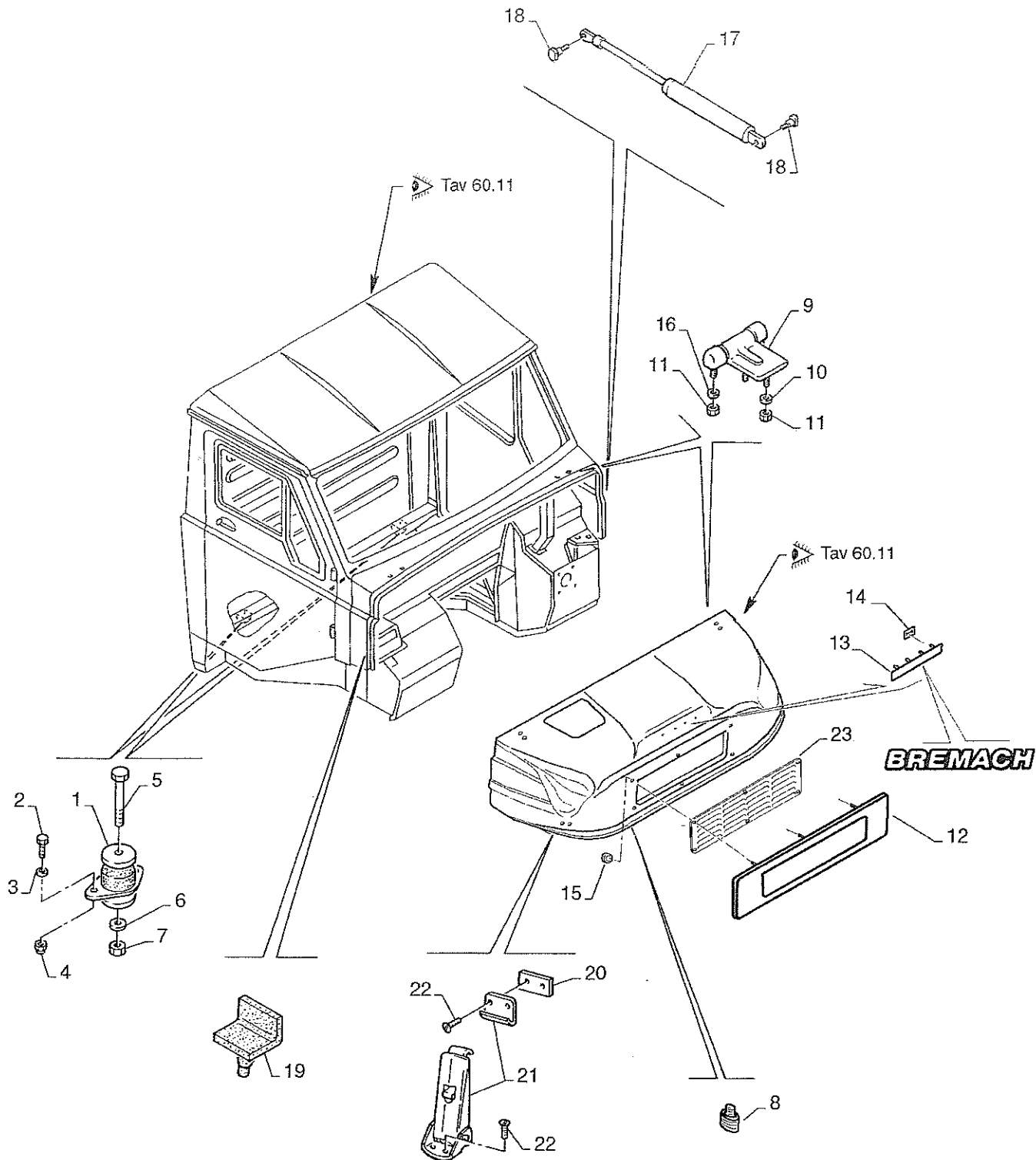

<input type="checkbox"/> 95 <input type="checkbox"/> 45	TUR <input type="checkbox"/> E3 <input type="checkbox"/>	20 <input type="checkbox"/>	4x4 <input type="checkbox"/>	<input type="checkbox"/> <input type="checkbox"/>	<input type="checkbox"/> <input type="checkbox"/>	CEE <input type="checkbox"/>	<input type="checkbox"/> <input type="checkbox"/>	<input type="checkbox"/> <input type="checkbox"/>	<input type="checkbox"/> YES <input type="checkbox"/> NO
------------------------------------------------------------	-------------------------------------------------------------	-----------------------------	------------------------------	---------------------------------------------------	---------------------------------------------------	------------------------------	---------------------------------------------------	---------------------------------------------------	-------------------------------------------------------------

BREMACH

Componenti vari cabina singola

Simple cab various components

TAV.60.151

EXTREME Ed. 04/2002

N. Pos.	COD.	DENOMINAZIONE	Q.ty	DESCRIPTION	Da matricola Serial number
1	E4068	Antivibrante cabina	4	Damper	200001
2	201041	Vite M 10x25 UNI 5739-65	8	Bolt	200001
3	203004	Rondella elastica 10x20x2,3	8	Washer	200001
4	202103	Dado M10 autobloccante UNI 7473	8	Nut	200001
5	201160	Vite antivibrante M 12x100 UNI 5931	4	Bolt	200001
6	203005	Rondella elastica 12x24x2,3 UNI 8836	4	Washer	200001
7	202006	Dado M12 UNI 5588-65	4	Nut	200001
8	90M1339	Gommino	2	Rubber	200001
9	90P1002	Cerniera cofano	2	Hinge	200001
10	203001	Rondella elastica 6x12x1,4	4	Washer	200001
11	202003	Dado M6 UNI 5587-68	8	Nut	200001
12	90P1038	Supporto maschera anteriore superiore	1	Support	200001
13	E4159	Targhetta "Bremach"	1	"Bremach" plate	200001
14	E4076	Molletta montaggio targhetta "Bremach"	4	Spring	200001
15	202107	Dado M5 autobloccante UNI 7473	6	Bolt	200001
16	203002	Rondella elastica 6x18x1,6 UNI 8836	4	Washer	200001
17	90P1015	Ammortizzatore a gas per cofano	2	Shock absorber	200001
18	K2085	Perno montaggio ammortizzatore a gas	2	Pin	200001
19	E4083	Gommino	1	Rubber	200001
20	90E1009	Piastrina per chiusura cofano	1	Plate	200001
21	E4124	Chiusura cofano	1	Closure	200001
22	201510	Vite	1	Bolt	200001
23	90P1030	Maschera anteriore superiore	1	Grill	200001

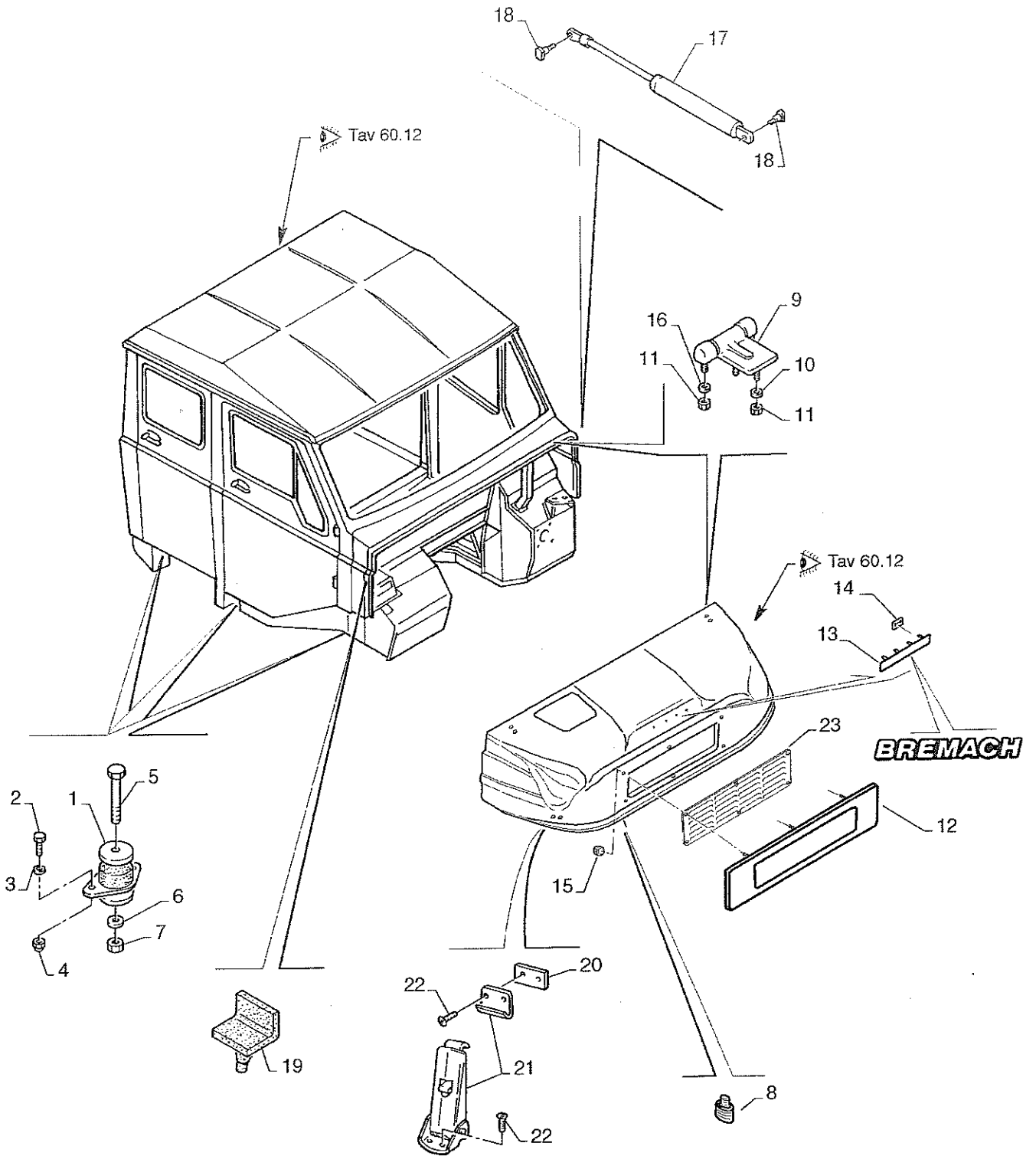

<input type="checkbox"/> 35 <input type="checkbox"/> 45	TUR <input type="checkbox"/> E3 <input type="checkbox"/>	<input type="checkbox"/> 20	<input type="checkbox"/> 4x4	<input type="checkbox"/> <input type="checkbox"/>	<input type="checkbox"/> <input type="checkbox"/>	CEE <input type="checkbox"/>	<input type="checkbox"/> <input type="checkbox"/>	<input type="checkbox"/> <input type="checkbox"/>	<input type="checkbox"/> YES <input type="checkbox"/> NO
------------------------------------------------------------	----------------------------------------------------------------	-----------------------------	------------------------------	---------------------------------------------------	---------------------------------------------------	---------------------------------	---------------------------------------------------	---------------------------------------------------	-------------------------------------------------------------

N. Pos.	COD.	DENOMINAZIONE	Q.ty	DESCRIPTION	Da matricola Serial number
1	E4068	Antivibrante cabina	4	Damper	200001
2	201041	Vite M 10x25 UNI 5739-65	8	Bolt	200001
3	203004	Rondella elastica 10x20x2,3	8	Washer	200001
4	202103	Dado M10 autobloccante UNI 7473	8	Nut	200001
5	201160	Vite antivibrante M 12x100 UNI 5931	4	Bolt	200001
6	203005	Rondella elastica 12x24x2,3 UNI 8836	4	Washer	200001
7	202006	Dado M12 UNI 5588-65	4	Nut	200001
8	90M1339	Gommino	2	Rubber	200001
9	90P1002	Cerniera cofano	2	Hinge	200001
10	203001	Rondella elastica 6x12x1,4	4	Washer	200001
11	202003	Dado M6 UNI 5587-68	8	Nut	200001
12	90P1038	Supporto maschera anteriore superiore	1	Support	200001
13	E4159	Targhetta "Bremach"	1	"Bremach" plate	200001
14	E4076	Molletta montaggio targhetta "Bremach"	4	Spring	200001
15	202107	Dado M5 autobloccante UNI 7473	6	Bolt	200001
16	203002	Rondella elastica 6x18x1,6 UNI 8836	4	Washer	200001
17	90P1015	Ammortizzatore a gas per cofano	2	Shock absorber	200001
18	K2085	Perno montaggio ammortizzatore a gas	2	Pin	200001
19	E4083	Gommino	1	Rubber	200001
20	90E1009	Piastrina per chiusura cofano	1	Plate	200001
21	E4124	Chiusura cofano	1	Closure	200001
22	201510	Vite	1	Bolt	200001
23	90P1030	Maschera anteriore superiore	1	Grill	200001

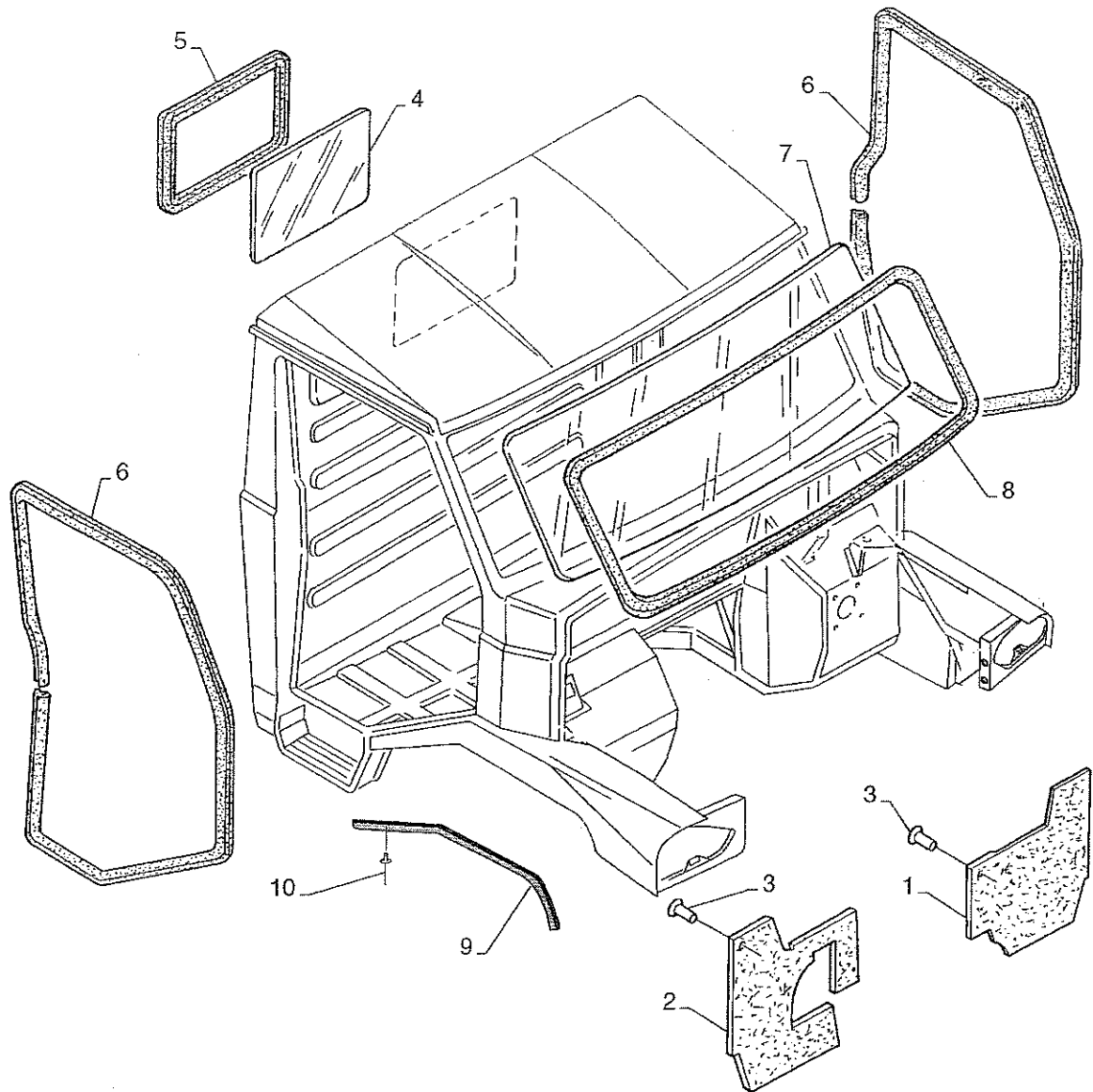

BREMACHVetri e guarnizioni cabina singola
Simple cab windows and gasket**TAV. 60.21**

EXTREME Ed. 04/2002

N. Pos.	COD.	DENOMINAZIONE	Q.ty	DESCRIPTION	Da matricola Serial number
1	E4107	Para spruzzi interno sinistro vano motore	1	Splash guard	200001
2	90N1162	Para spruzzi interno destro vano motore	1	Splash guard	200001
3	E4169	Rivetto 4,9x16	6	Rivet	200001
4	83235	Cristallo posteriore	1	Glass	200001
5	83236	Guarnizione cristallo posteriore	1	Gasket	200001
6	90P1031	Guarnizione profilo portiera anteriore	2	Gasket	200001
7	90P1029	Cristallo parabrezza	1	Glass	200001
8	90P1032	Guarnizione cristallo parabrezza con tenditore	1	Gasket	200001
9	90P6028	Profilo in gomma per parafango anteriore	2	Cover	200001
10	E4169	Rivetto	24	Rivet	200001

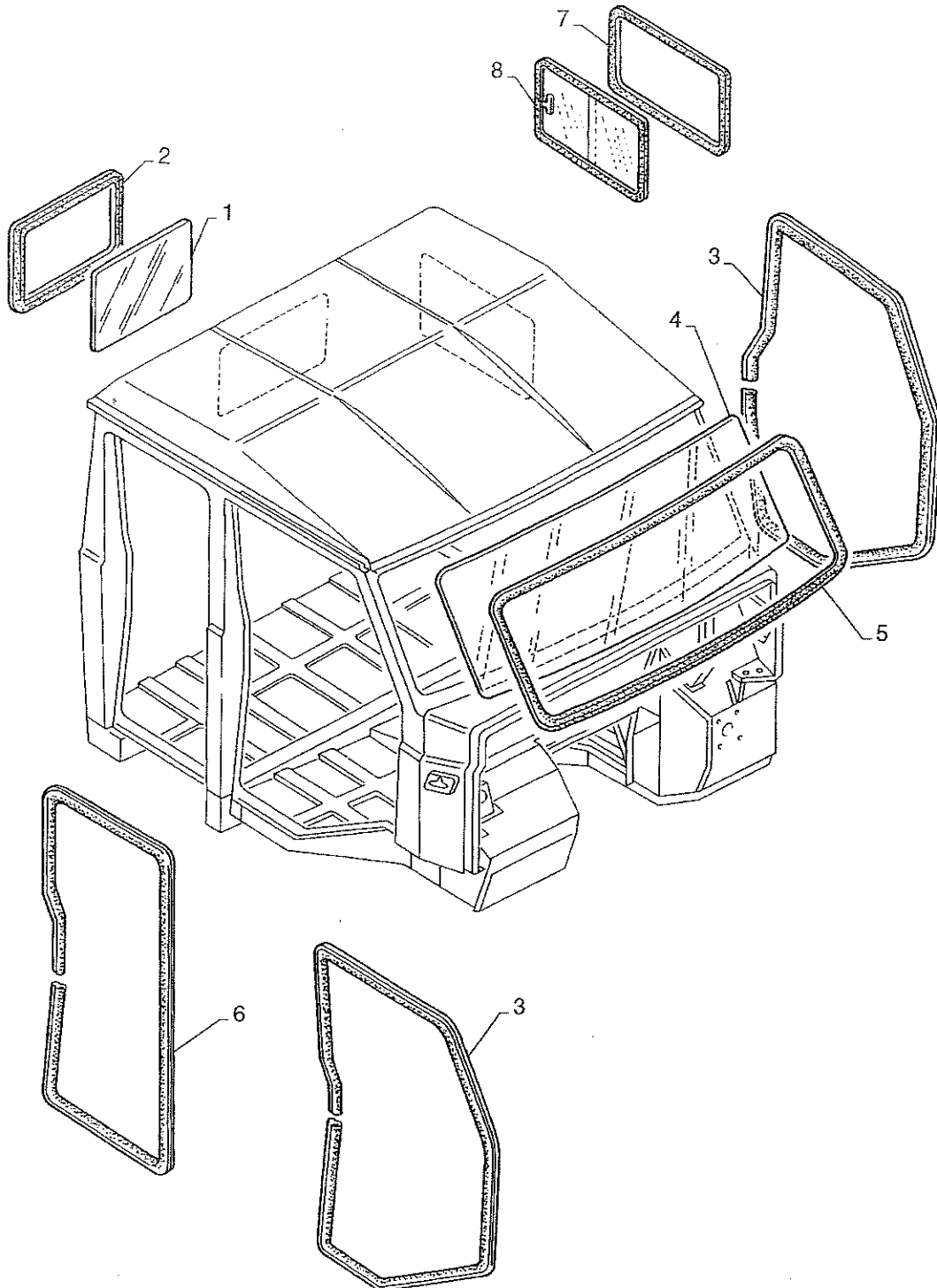

<input type="checkbox"/> 35 <input type="checkbox"/> 45	TUR <input type="checkbox"/> E3 <input type="checkbox"/>	<input type="checkbox"/> 20	<input type="checkbox"/> 4x4	<input type="checkbox"/> <input type="checkbox"/>	<input type="checkbox"/> <input type="checkbox"/>	CEE <input type="checkbox"/>	<input type="checkbox"/> <input type="checkbox"/>	<input type="checkbox"/> <input type="checkbox"/>	<input type="checkbox"/> YES <input type="checkbox"/> NO
------------------------------------------------------------	----------------------------------------------------------------	-----------------------------	------------------------------	---------------------------------------------------	---------------------------------------------------	---------------------------------	---------------------------------------------------	---------------------------------------------------	-------------------------------------------------------------

BREMACHVetri e guarnizioni cabina doppia
Double cab windows and gasket**TAV. 60.22**

EXTREME Ed. 04/2002

N. Pos.	COD.	DENOMINAZIONE	Q.ty	DESCRIPTION	Da matricola Serial number
1	83235	Cristallo posteriore	1	Glass	200001
2	83236	Guarnizione cristallo posteriore	1	Gasket	200001
3	90P1031	Guarnizione profilo portiera anteriore	2	Gasket	200001
4	90P1029	Cristallo parabrezza	1	Glass	200001
5	90P1032	Guarnizione cristallo parabrezza con tenditore	1	Gasket	200001
6	82313	Guarnizione porta posteriore	1	Gasket	200001
7	E4128	Guarnizione vetro laterale	1	Gasket	200001
8	ED4127	Vetro laterale destro	1	Glass	200001

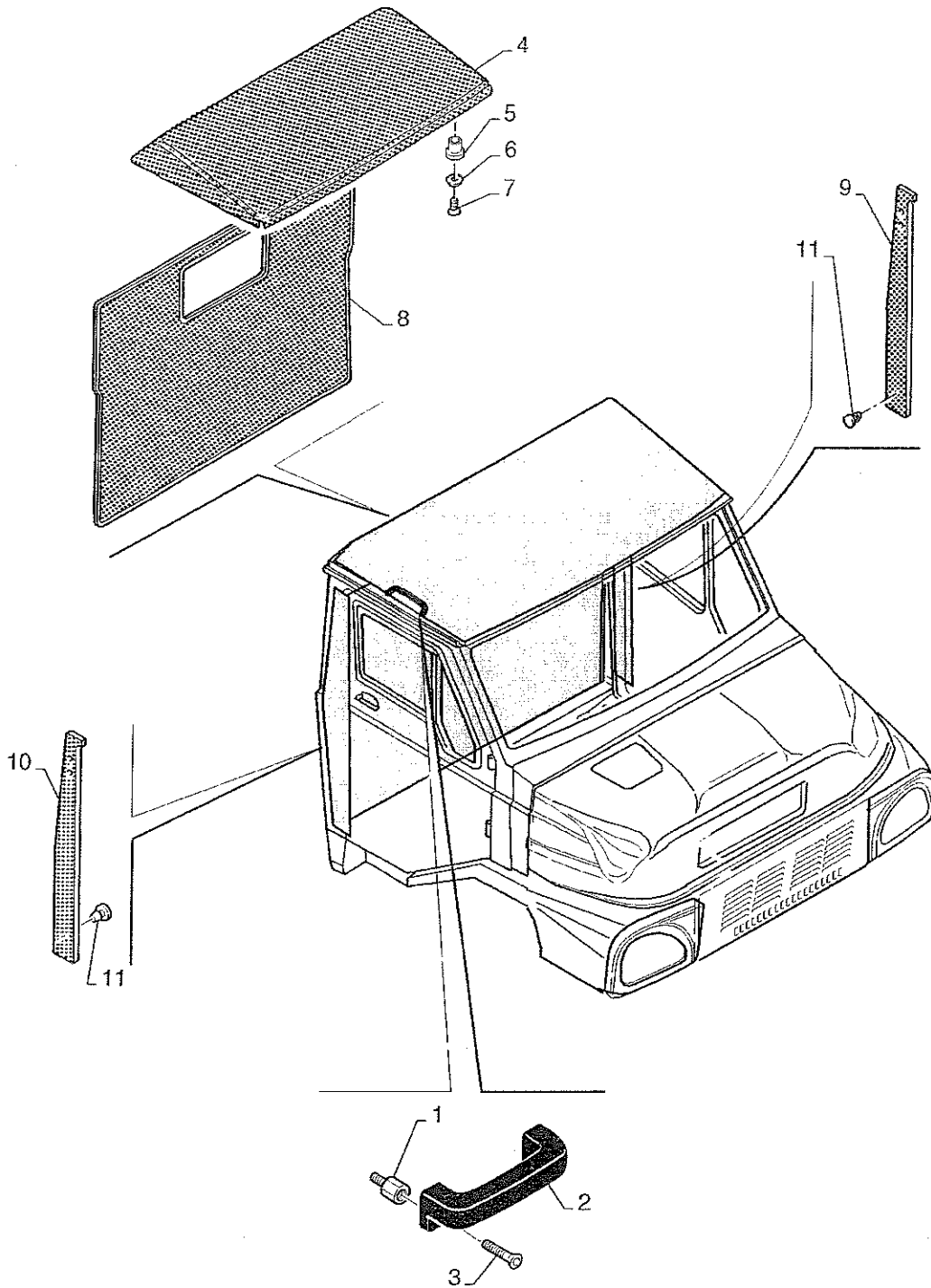

<input type="checkbox"/> 35	TUR <input type="checkbox"/> E3	20 <input type="checkbox"/>	4x4 <input type="checkbox"/>	<input type="checkbox"/>	<input type="checkbox"/>	<input type="checkbox"/>	CEE <input type="checkbox"/>	<input type="checkbox"/>	<input type="checkbox"/>	<input type="checkbox"/>	<input type="checkbox"/> YES <input type="checkbox"/> NO
-----------------------------	---------------------------------	-----------------------------	------------------------------	--------------------------	--------------------------	--------------------------	------------------------------	--------------------------	--------------------------	--------------------------	-------------------------------------------------------------

BREMACHRivestimenti interni cabina singola
Simple cab inside panels**TAV. 60.31**

EXTREME Ed. 04 / 2002

N. Pos.	COD.	DENOMINAZIONE	Q.ty	DESCRIPTION	Da matricola Serial number
1	E4175	Bussola per montaggio maniglia tiraporta	1	Bush	200001
2	92P7017	Maniglia di cortesia a soffitto	1	Handle	200001
3	201201	Vite M 6x20 UNI 5933 per mont. maniglia cortesia	2	Bolt	200001
4	90P6063	Rivestimento sottotetto	1	Cover	200001
5	90P4070	Bussola M6 montaggio rivestimento sottotetto	9	Bush	200001
6	203300	Rondella nera F15	5	Washer	200001
7	201303	Vite BTC M 6x20 UNI 7689	5	Bolt	200001
8	90P6060	Rivestimento parete posteriore	1	Cover	200001
9	90P6061	Rivestimento montante sinistro	1	Cover	200001
10	90P6062	Rivestimento montante destro	1	Cover	200001
11	83984	Collegamento a pressione per mont. rivestimenti	8	Connection	200001

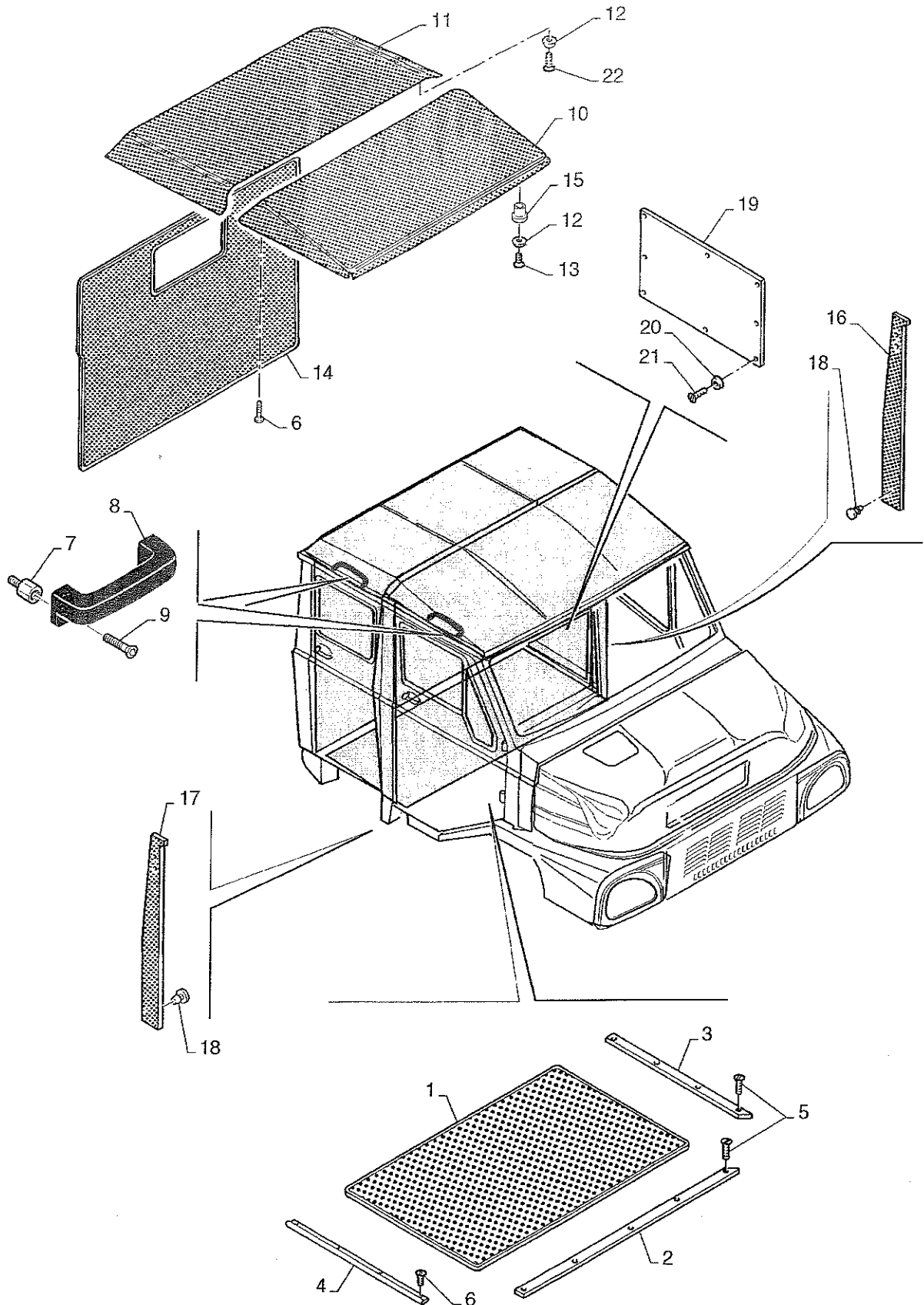

BREMACHRivestimenti interni cabina doppia
Double cab inside panels**TAV. 60.32**

EXTREME Ed. 04/2002

N. Pos.	COD.	DENOMINAZIONE	Q.ty	DESCRIPTION	Da matricola Serial number
1	E4125	Tappeto a boile posteriore	1	Mat	200001
2	90P6019	Listello di fissaggio tappeto lato lungo (1500mm)	1	Fillet	200001
3	90P6022	Listello di fissaggio tappeto lato sinistro	1	Fillet	200001
4	E4066	Battitacco	1	Thre shold	200001
5	204005	Vite autofilettante 3,5x13 UNI 6956	10	Bolt	200001
6	204010	Vite autofilettante 4,8x22 UNI 6954 brunita	7	Bolt	200001
7	E4175	Bussola per montaggio maniglia tiraporta	1	Bush	200001
8	92P7017	Maniglia di cortesia a soffitto	2	Handle	200001
9	201201	Vite M 6x20 UNI 5933 per mont. maniglia cortesia	4	Bolt	200001
10		Rivestimento sottotetto anteriore	1	Cover	200001
11	E4136	Rivestimento sottotetto posteriore	1	Cover	200001
12	203300	Rondella nera F15	14	Washer	200001
13	201303	Vite BTC M 6x20 UNI 7689	7	Bolt	200001
14		Rivestimento parete posteriore	1	Cover	200001
15	90P4070	Bussola M6 montaggio rivest. ant. sottotetto	4	Bush	200001
16		Rivestimento montante sinistro	1	Cover	200001
17		Rivestimento montante destro	1	Cover	200001
18	83984	Collegamento a pressione per mont. rivestimenti	8	Connection	200001
19	E4134	Pannello posteriore sinistro	1	Panel	200001
20	203300	Rondella nera F15	8	Washer	200001
21	201040	Vite M 10x20	8	Bolt	200001
22	201301	Vite	1	Bolt	200001

Codici in bianco : da richiedere al magazzino ricambi prima di inviare l'ordine.

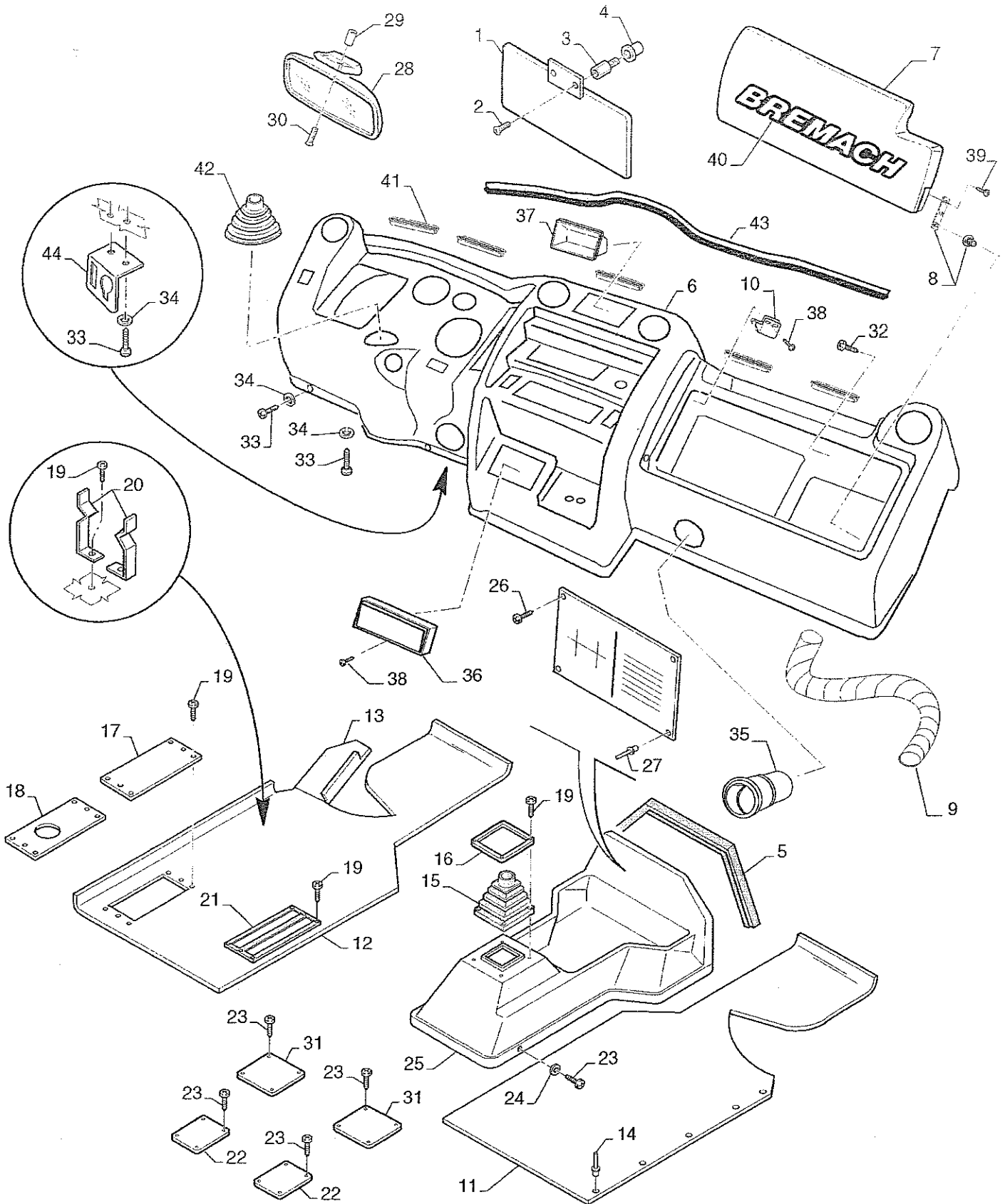

<input type="checkbox"/> 35 <input type="checkbox"/> 45	TUR E3 <input type="checkbox"/>	20 <input type="checkbox"/>	4x4 <input type="checkbox"/>	<input type="checkbox"/> <input type="checkbox"/>	<input type="checkbox"/> <input type="checkbox"/>	CEE <input type="checkbox"/>	<input type="checkbox"/> <input type="checkbox"/>	<input type="checkbox"/> <input type="checkbox"/>	<input type="checkbox"/> <input type="checkbox"/>	<input type="checkbox"/> YES <input type="checkbox"/> NO
------------------------------------------------------------	------------------------------------	-----------------------------	------------------------------	---------------------------------------------------	---------------------------------------------------	------------------------------	---------------------------------------------------	---------------------------------------------------	---------------------------------------------------	-------------------------------------------------------------

N. Pos.	COD.	DENOMINAZIONE	Q.ty	DESCRIPTION	Da matricola Serial number
1	90P6067	Ala parasole	2	Sunshade	200001
2	201306	Vite brunita M 6x16 UNI 7689	4	Bolt	200001
3	E4175	Supporto aletta parasole	2	Support	200001
4	90P4070	Bussola M 6 917-6	2	Bush	200001
5	E4052	Guarnizione tunnell cambio	1	Gasket	200001
6	90P1639	Cruscotto	1	Dashboard	200001
7	90P1630	. Sportello con logo Bremach	1	Flap door	200001
8	90P1635	. Coppia bussole e perni per montaggio sportello	1	Flap door steady pin	200001
9	90P1636	. Tubo canalizzazione aria	1	Tube	200001
10	90P1628	. Chiusura (tipo cricchetto) a spinta per sportello	1	Push lock sistem	200001
11	94P6001	Rivestimento destro pavimento in lamiera	1	Cover	200001
12	94P6000	Rivestimento sinistro pavimento in lamiera	1	Cover	200001
13	91P6002	Poggiapiedi sinistro in lamiera	1	Footrest	200001
14	E4095	Rivetto 4,8x16 per rivestimenti pavimento	15	Rivet	200001
15	83556	Cuffia leva marce	1	Boot	200001
16	83557	Cornice metallica per montaggio cuffia	1	Cornice	200001
17	G3001	Coperchio per foro inst. telecomando ribaltabile	1	Cover	200001
18	90P6056	Piastra per inst. telecomando ribalt. per vers.VER/CR	1	Plate	200001
19	204002	Vite autofil. testa a croce 3,5x19 UNI 6954	19	Bolt	200001
20	90P6057	Molletta per fissaggio comando ribaltabile CEE	2	Spring	200001
21	90P9610	Piastra	1	Plate	200001
22	D4012	Coperchio	2	Cover	200001
23	204001	Vite autofilettante testa croce 3,5x13 UNI 6954	26	Washer	200001
24	203102	Rondella piana 5x15x1,6	10	Washer	200001
25	91P9601	Tunnell cambio insonorizzato	1	Sound prooe cover	200001
26	204011	Vite autofil. 4,8x45 UNI 6954	2	Bolt	200001
27	83544	Rivetto 3,2x10 per mont. targa esplicativa uso marce	2	Rivet	200001
28	E4162	Specchio retrovisore	1	Mirror	200001
29	E4111	Bussola M 5-0917-25	2	Bush	200001
30	201509	Vite testa croce M 50x30 UNI 7687	2	Bolt	200001
31	90P1012	Piastra chiusura foro inst. com. riduttore 1:10,24	2	Plate	200001
32	201002	Vite M 5x30 UNI 5739-65 per montaggio cruscotto	1	Bolt	200001
33	204010	Vite autofil. 4,8x22 UNI 6954 per mont. cruscotto	4	Bolt	200001
34	203300	Rondella nera F15	6	Washer	200001
35	90P1622	Diffusore aria rotondo	6	Diffusion air	200001
36	90P1623	Posacenere	1	Ashtray	200001
37	90P1624	Portaoggetti / portamonete	1	Holder	200001
38	204014	Vite autof. 3.5x25	5	Bolt	200001
39	201501	Vite acc. inox M 4x10	4	Bolt	200001
40	E4159	logo "BREMACH"	1	"BREMACH" plate	200001
41	92P1602	Diffusore aria lineare	5	Diffusion air	200001
42	90P2009	Cuffia piantone	1	Boot	200001
43	90P1644	Guarnizione anter. cruscotto	1	Gasket	200001
44	91I9101	Assieme pulsante tester presa diagnostica	1	Tester	200001

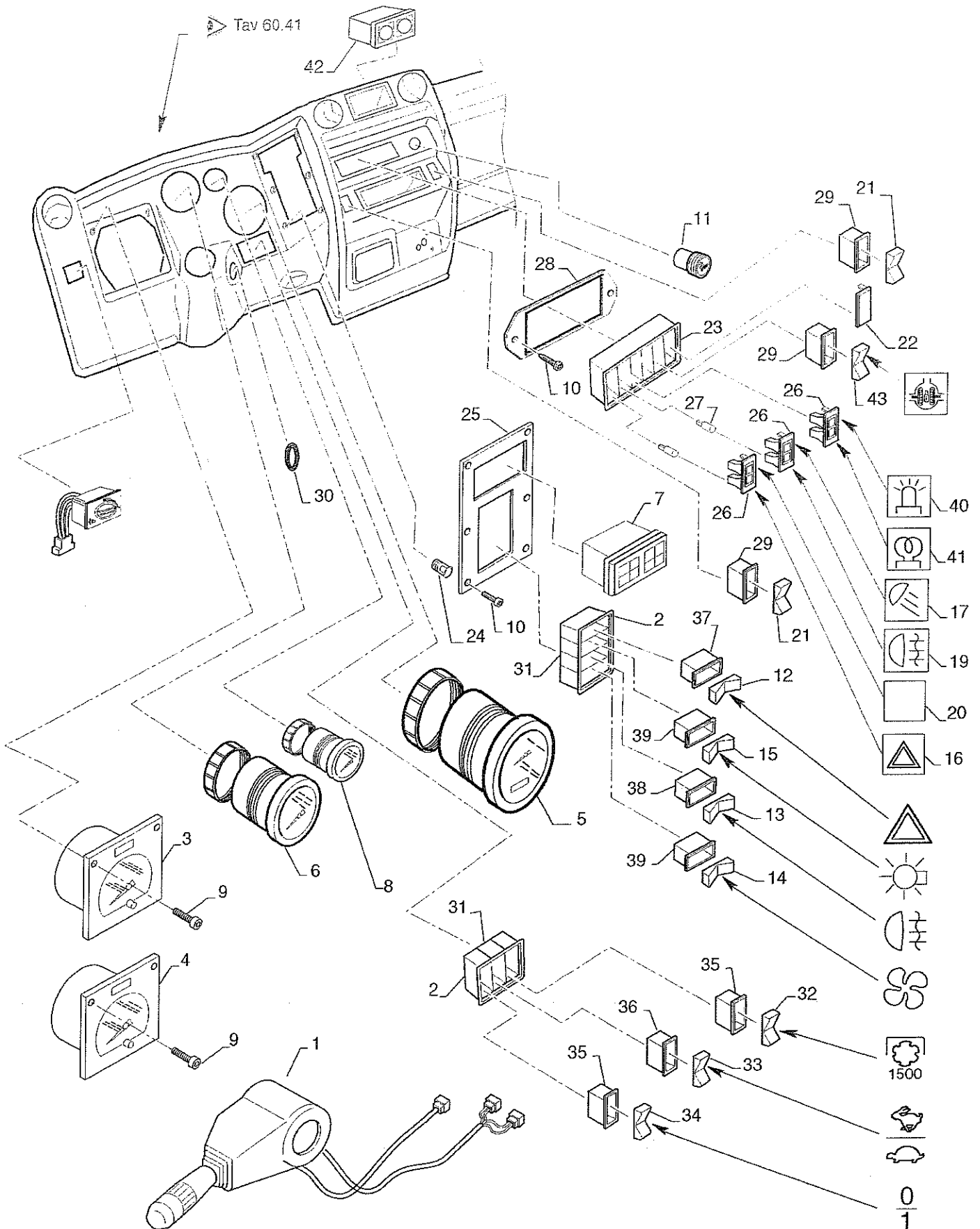

<input type="checkbox"/> 35	TUR <input type="checkbox"/>	<input type="checkbox"/> 20	<input type="checkbox"/> 4x4	<input type="checkbox"/>	<input type="checkbox"/>	<input type="checkbox"/>	CEE <input type="checkbox"/>	<input type="checkbox"/>	<input type="checkbox"/>	<input type="checkbox"/>	<input type="checkbox"/>	<input type="checkbox"/> YES	<input type="checkbox"/> NO
<input type="checkbox"/> 45	E3 <input type="checkbox"/>							<input type="checkbox"/>	<input type="checkbox"/>	<input type="checkbox"/>	<input type="checkbox"/>		

N. Pos.	COD.	DENOMINAZIONE	Q.ty	DESCRIPTION	Da matricola Serial number
1	90I9117	Gruppo comando luci e devigiuida	1	Lights drive	200001
2	90I1103	Telaio (componibile) laterale	4	Frame	200001
3	90P1008	Tachimetro conta Km per PT 35	1	Speedometer	200001
4	90P1011	Tachigrafo elettronico per PT 45	1	Tachygrapher	200001
5	90I1148	Contatore e livello carburante	1	Mileage-recorder	200001
6	90I1095	Contagiri	1	Rev counter	200001
7	90I1139	Maschera per N.8 spie segnalazione	1	Grill	200001
8	90I1094	Indicatore temperatura acqua	1	Water temperature	200001
9	201002	Vite M 5x30 UNI 5739-65	10	Bolt	200001
10	201503	Vite testa croce M 5x15	8	Bolt	200001
11	90P1609	Accendisigari completo	1	Safety lighter	200001
12	90I1080	Tasto basculante	1	Pushbutton	200001
13	90I1082	Tasto basculante	1	Pushbutton	200001
14	90I1081	Tasto basculante	1	Pushbutton	200001
15	90I1085	Tasto basculante	1	Pushbutton	200001
16	90I1121	Vetro rosso com. emergenza	1	Glass	200001
17	90I1131	Vetro verde com. luci	1	Glass	200001
18	90I1115	Regolazione fari interna	1	Remote headlights control	200001
19	90I1022	Vetro giallo per pulsante com. faro post. antinebbia	1	Glass	200001
20	90I1118	Vetro verde neutro	1	Glass	200001
21	90I1084	Tasto basculante	1	Pushbutton	200001
22	90P1607	Tappo per pulsante	1	Screw plug	200001
23	92P1604	Mascherina N.6 posti	1	Grill	200001
24	E4110	Dado in gabbia M5	6	Nut	200001
25	2853.006	Telaio porta strumentazione	1	Frame	200001
26	90I1083	Telaio porta vetrini	3	Frame	200001
27	90I1030	Lampada per spie di segnalazione	4	Lamp	200001
28	90P1643	Supporto telaio (6 posti)	1	support	200001
29	90I1108	Tasto base	2	Anchoring key	200001
30	92P6016	Gommino per blocco accensione	1	Rubber	200001
31	90I1102	Telaio (componibile) centrale	3	Frame	200001
32	90I1144	Tasto basculante	1	Pushbutton	200001
33	90I1142	Tasto basculante	1	Pushbutton	200001
34	90I1143	Tasto basculante	1	Pushbutton	200001
35	90I1146	Tasto base	1	Anchoring key	200001
36	90I1145	Tasto basculante	2	Pushbutton	200001
37	90I1110	Tasto basculante	1	Pushbutton	200001
38	90I1107	Tasto basculante	1	Pushbutton	200001
39	90I1109	Tasto basculante	2	Pushbutton	200001
40	90I1141	Vetro (spia comando)	1	Glass	200001
41	90I1040	Vetro (preriscaldamento motore)	1	Glass	200001
42	90P1627	Inclinometro	1	Land meter	200001
43	90I1086	Tasto basculante	1	Push button	200001

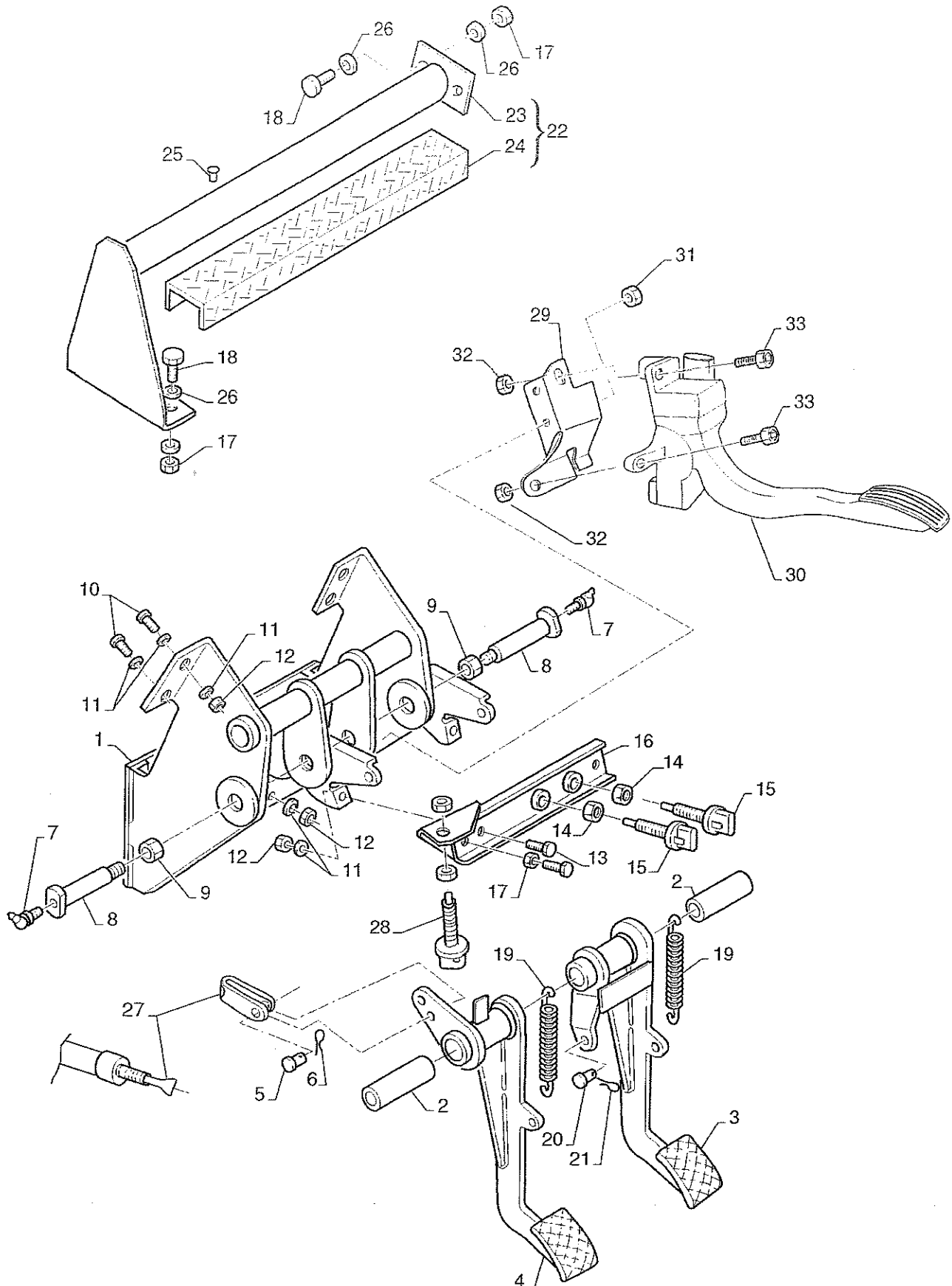

	<input type="checkbox"/> 35		TUR <input type="checkbox"/> E3		<input type="checkbox"/> 20		<input type="checkbox"/> 4x4		<input type="checkbox"/> 20		<input type="checkbox"/> 20	CEE	<input type="checkbox"/>		<input type="checkbox"/> 20		<input type="checkbox"/> 20		<input type="checkbox"/> YES	<input type="checkbox"/> NO
--	-----------------------------	--	---------------------------------	--	-----------------------------	--	------------------------------	--	-----------------------------	--	-----------------------------	-----	--------------------------	--	-----------------------------	--	-----------------------------	--	------------------------------	-----------------------------

N. Pos.	COD.	DENOMINAZIONE	Q.ty	DESCRIPTION	Da matricola Serial number
1	E4050	Supporto pedaliera	1	Support	200001
2	809035	Boccola 16x21x60	2	Bushing	200001
3	E4046	Pedale freno	1	Brake pedal	200001
4	E4047	Pedale frizione	1	Pedal	200001
5	83371	Perno leva pedale frizione	1	Pin	200001
6	205001	Copiglia Ø 2x20 UNI 1336A	1	Cotter	200001
7	D4032	Ingrassatore a 90°	2	Fitting	200001
8	80943	Spinotto	2	Connector	200001
9	202103	Dado M10 autobloccante UNI 7473 per spinotto	2	Nut	200001
10	201022	Vite M 8x25 UNI 5739-65	4	Bolt	200001
11	203003	Rondella elastica 8x16x1,9	12	Washer	200001
12	202004	Dado M8 UNI 5587-68	8	Nut	200001
13	201021	Vite M 8x20 UNI 5739-65	2	Bolt	200001
14	202021	Dado M 12x1,5 H6 UNI 5589	2	Nut	200001
15	901129	Interruttore luce freni a pulsante	2	Switch	200001
16	94H5001	Supporto interruttore luce freni	1	Support	200001
17	202003	Dado M6 UNI 5587-68	5	Nut	200001
18	201012	Vite M 6x20 UNI 5739	5	Bolt	200001
19	E4100	Molla per pedali	2	Spring	200001
20	81535	Perno leva pedale freno	1	Pin	200001
21	205001	Copiglia	1	Cotter	200001
22	K2081	Appoggia piedi	1	Foot rest	200001
23	K2079	. Appoggia piedi	1	. Foot rest	200001
24	K2080	. Lamiera alluminio per appoggia piedi	1	. Alluminium plate	200001
25	E4095	Rivetto 4,8x16	2	Rivet	200001
26	203002	Rondella elastica 6x18x1,6	8	Washer	200001
27	90L5007	Cavo comando frizione	1	clutch cable	200001
28	901130	Interruttore frizione	1	Switch	200001
29	91L5001	Supporto pedale acceleratore E3	1	Support	200001
30	91L5002	Pedale acceleratore	1	Accelerator pedal	200001
31	202101	Dado autobloccante M6	2	Nut	200001
32	202102	Dado autobloccante M8	2	Nut	200001
33	201109	Vite a brugola M8x25	2	Bolt	200001

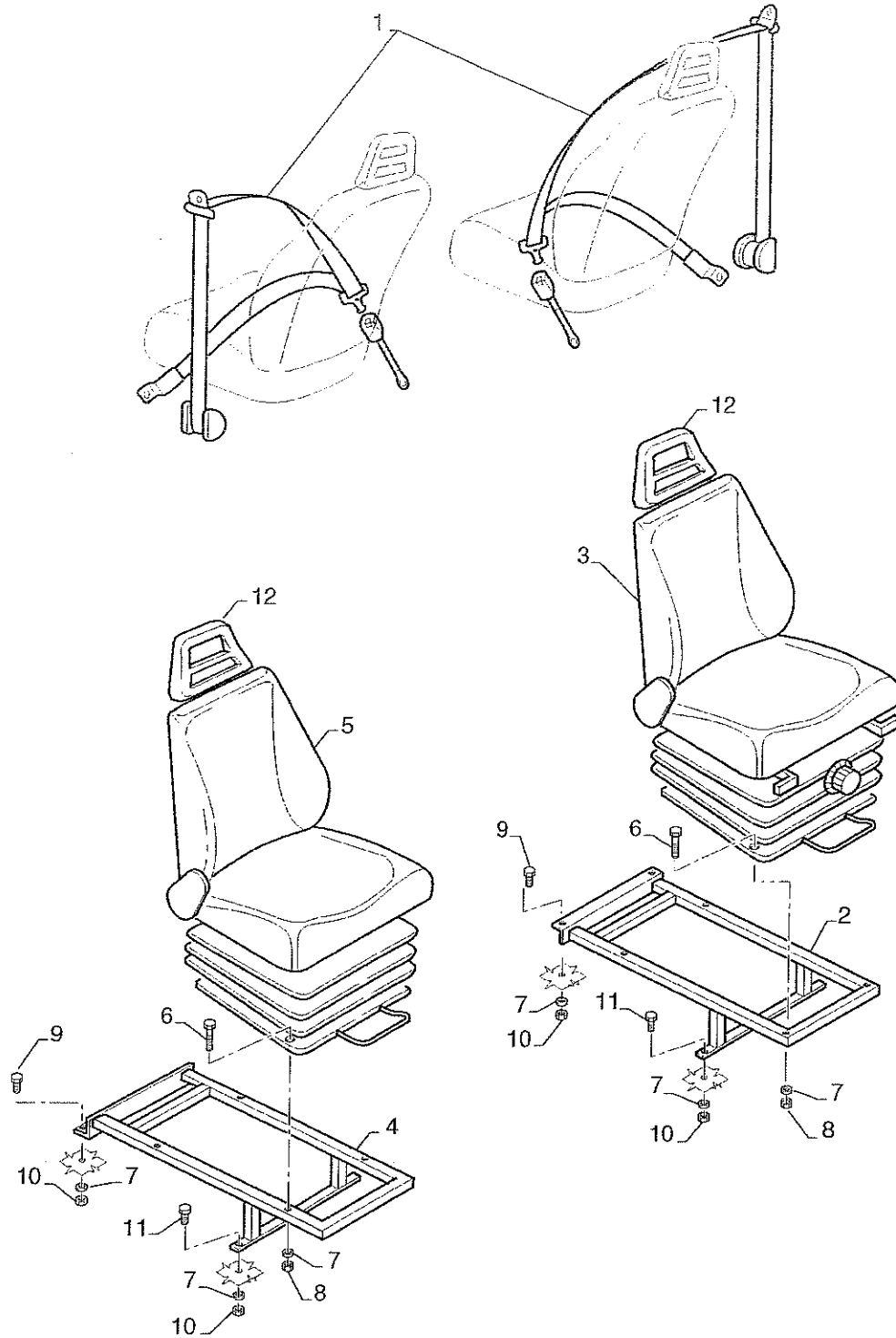

<input type="checkbox"/> 35 <input type="checkbox"/> 45	TUR <input type="checkbox"/> E3 <input type="checkbox"/>	20	4x4	<input type="checkbox"/> <input type="checkbox"/>	<input type="checkbox"/> <input type="checkbox"/>	CEE <input type="checkbox"/>	<input type="checkbox"/> <input type="checkbox"/>	<input type="checkbox"/> <input type="checkbox"/>	<input type="checkbox"/> YES <input type="checkbox"/> NO
------------------------------------------------------------	----------------------------------------------------------------	----	-----	---------------------------------------------------	---------------------------------------------------	---------------------------------	---------------------------------------------------	---------------------------------------------------	-------------------------------------------------------------

BREMACH

Sedili e cinture di sicurezza (2 posti anteriori)

Seats and safety belts (2 front seats)

TAV.60.511

EXTREME Ed. 04 / 2002

N. Pos.	COD.	DENOMINAZIONE	Q.ty	DESCRIPTION	Da matricola Serial number
1	90P6045	Coppia cinture anteriori	1	Front safety belt set	200001
2	90P5025	Supporto sedile guida	1	Operator's seat stand	200001
3	90P5024	Sedile guida	1	Operator's seat	200001
4	90P5027	Supporto sedile passeggero	1	Seat stand	200001
5	90P5026	Sedile passeggero	1	Seat	200001
6	201027	Vite M 8x45 UNI 5737-65	8	Bolt	200001
7	203110	Rondella piatta 8x24x1,7	16	Washer	200001
8	202004	Dado M8 UNI 5587-68	8	Nut	200001
9	201021	Vite M 8x20 UNI 5739-65	4	Bolt	200001
10	202102	Dado M8 autobloccante UNI 7473	8	Self-locking nut	200001
11	201023	Vite M 8x30 UNI 5739-65	4	Bolt	200001
12	90P5028	Poggiatesta	2	Headrest	200001

BREMACHSedili e cinture di sicurezza (3 posti anteriori)
Seats and safety belts (3 front seats)**TAV.60.512**

EXTREME Ed. 04 / 2002

N. Pos.	COD.	DENOMINAZIONE	Q.ty	DESCRIPTION	Da matricola Serial number
1	90P6045	Coppia cinture anteriori	1	Front safety belt set	200001
2	90P6046	Cintura centrale 3° posto	1	Belt	200001
3	90P5025	Supporto sedile guida	1	Operator's seat stand	200001
4	90P5024	Sedile guida	1	Operator's seat	200001
5	90P5018	Supporto sedile 2 posti	1	Seat stand	200001
6	90P5017	Sedile 2 posti anteriore	1	Seat	200001
7	201027	Vite M 8x45 UNI 5737-65	4	Bolt	200001
8	203110	Rondella piatta 8x24x1,7	16	Washer	200001
9	202004	Dado M8 UNI 5587-68	8	Nut	200001
10	201021	Vite M 8x20 UNI 5739-65	4	Bolt	200001
11	202102	Dado M8 autobloccante UNI 7473	8	Self-locking nut	200001
12	201023	Vite M 8x30 UNI 5739-65	4	Bolt	200001
13	90P5028	Poggiatesta	2	Headrest	200001

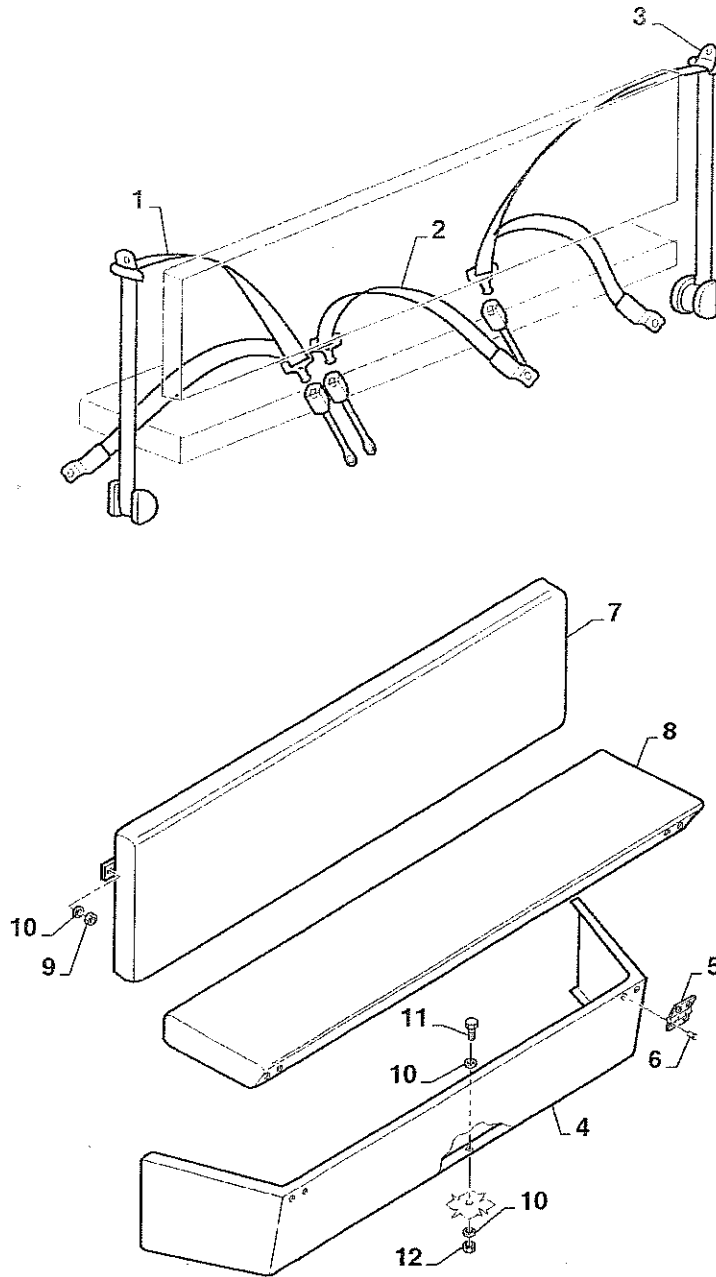

BREMACH

Sedili e cinture di sicurezza (3 posti posteriori)

Seats and safety belts (3 rear seats)

TAV. 60.52

EXTREME Ed. 04 / 2002

N. Pos.	COD.	DENOMINAZIONE	Q.ty	DESCRIPTION	Da matricola Serial number
1	90P6047	Cintura passeggero sinistra posteriore	1	Belt	200001
2	90P6048	Cintura passeggero centrale posteriore	1	Belt	200001
3	90P6049	Cintura passeggero destro posteriore	1	Belt	200001
4	E4131	Supporto panca posteriore	1	Support	200001
5	E4130	Cerniera per panca posteriore	2	Hinge	200001
6	E4095	Rivetto 4,8x16 per montaggio cerniere panca	12	Rivet	200001
7	90P5007	Schienale panca posteriore	1	Seat back	200001
8	90P5008	Sedile panca posteriore	1	Seat	200001
9	202003	Dado M6 per montaggio schienale	4	Nut	200001
10	203002	Rondella elastica 6x18x1,6	8	Washer	200001
11	201012	Vite M 6x20 UNI 5739	4	Bolt	200001
12	202101	Dado M6 autobloccante	4	Nut	200001

TAV. 60.61

EXTREME Ed. 04/2002

Insonorizzazione vano motore
Sound insulation in engine area

BREMACH

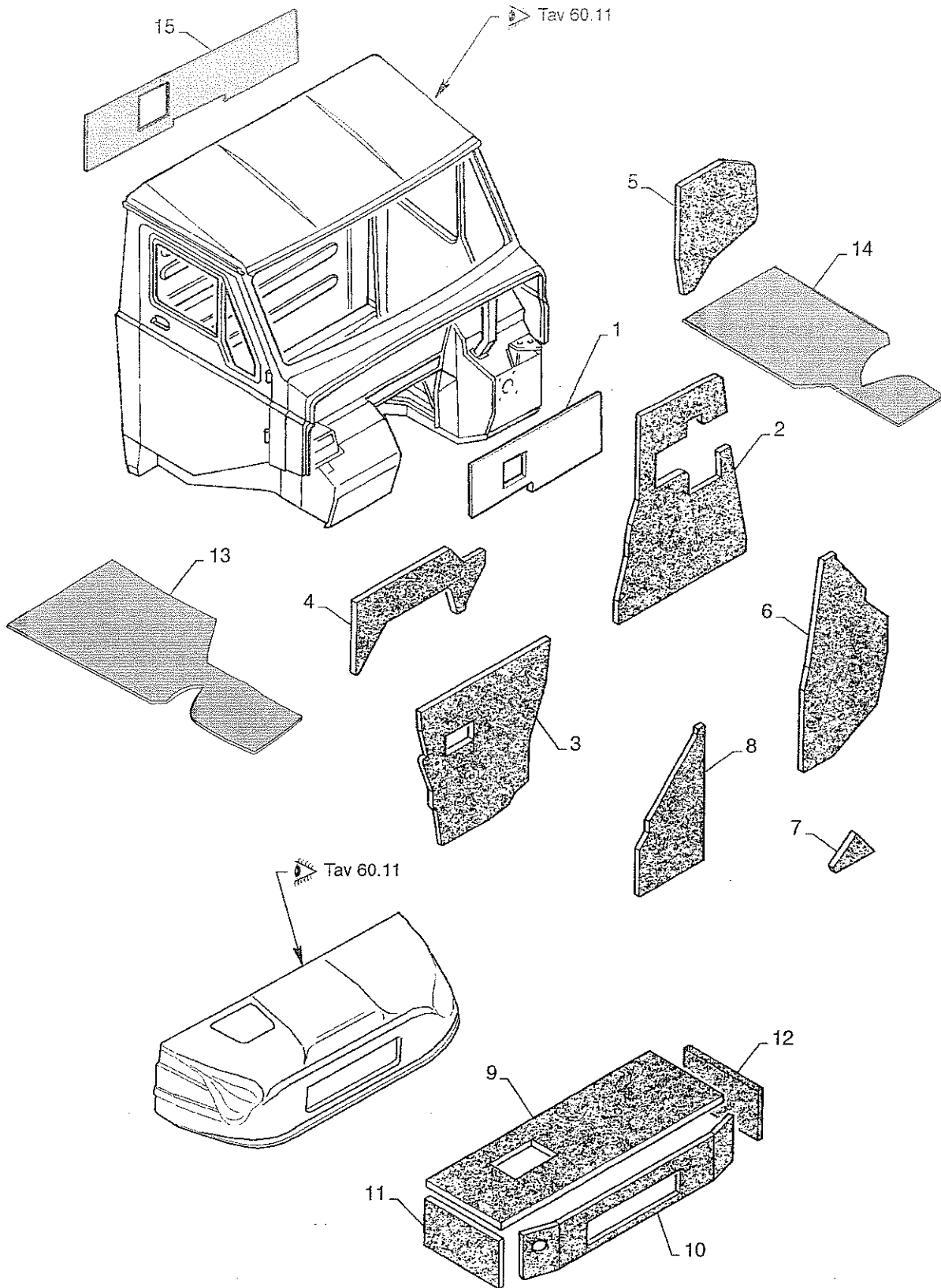

<input type="checkbox"/> 35 <input type="checkbox"/> 45	TUR <input type="checkbox"/> E3 <input type="checkbox"/>	20	4x4	<input type="checkbox"/> <input type="checkbox"/>	<input type="checkbox"/> <input type="checkbox"/>	<input type="checkbox"/> <input type="checkbox"/>	CEE <input type="checkbox"/>	<input type="checkbox"/> <input type="checkbox"/>	<input type="checkbox"/> <input type="checkbox"/>	<input type="checkbox"/> <input type="checkbox"/>	<input type="checkbox"/> YES <input type="checkbox"/> NO
------------------------------------------------------------	----------------------------------------------------------------	----	-----	------------------------------------------------------	------------------------------------------------------	------------------------------------------------------	---------------------------------	------------------------------------------------------	------------------------------------------------------	------------------------------------------------------	-------------------------------------------------------------

BREMACHInsonorizzazione vano motore
Sound insulation in engine area**TAV. 60.61**

EXTREME Ed. 04 / 2002

N. Pos.	COD.	DENOMINAZIONE	Q.ty	DESCRIPTION	Da matricola Serial number
1	90P4071	Pannello centrale parete cabina	1	Panel	200001
2	90P4001	Pannello lato sinistro vano motore	1	Panel	200001
3	90P4002	Pannello lato destro vano motore	1	Panel	200001
4	90P4003	Pannello frontale vano motore	1	Panel	200001
5	90P4004	Pannello laterale destro vano motore interno	1	Panel	200001
6	90P4005	Pannello laterale sinistro vano motore interno	1	Panel	200001
7	90P4006	Pannello laterale destro vano motore esterno	1	Panel	200001
8	90P4007	Pannello laterale sinistro vano motore esterno	1	Panel	200001
9	90P4008	Pannello superiore cofano	1	Panel	200001
10	90P4077	Pannello frontale cofano	1	Panel	200001
11	90P4010	Pannello laterale destro cofano	1	Panel	200001
12	90P4023	Pannello laterale sinistro cofano	1	Panel	200001
13	H2025	Smorzante tappeto lato passeg.	1	Panel	200001
14	H2026	Smorzante tappeto lato guida	1	Panel	200001
15	H2024	Pannello interno vano cabina	1	Panel	200001

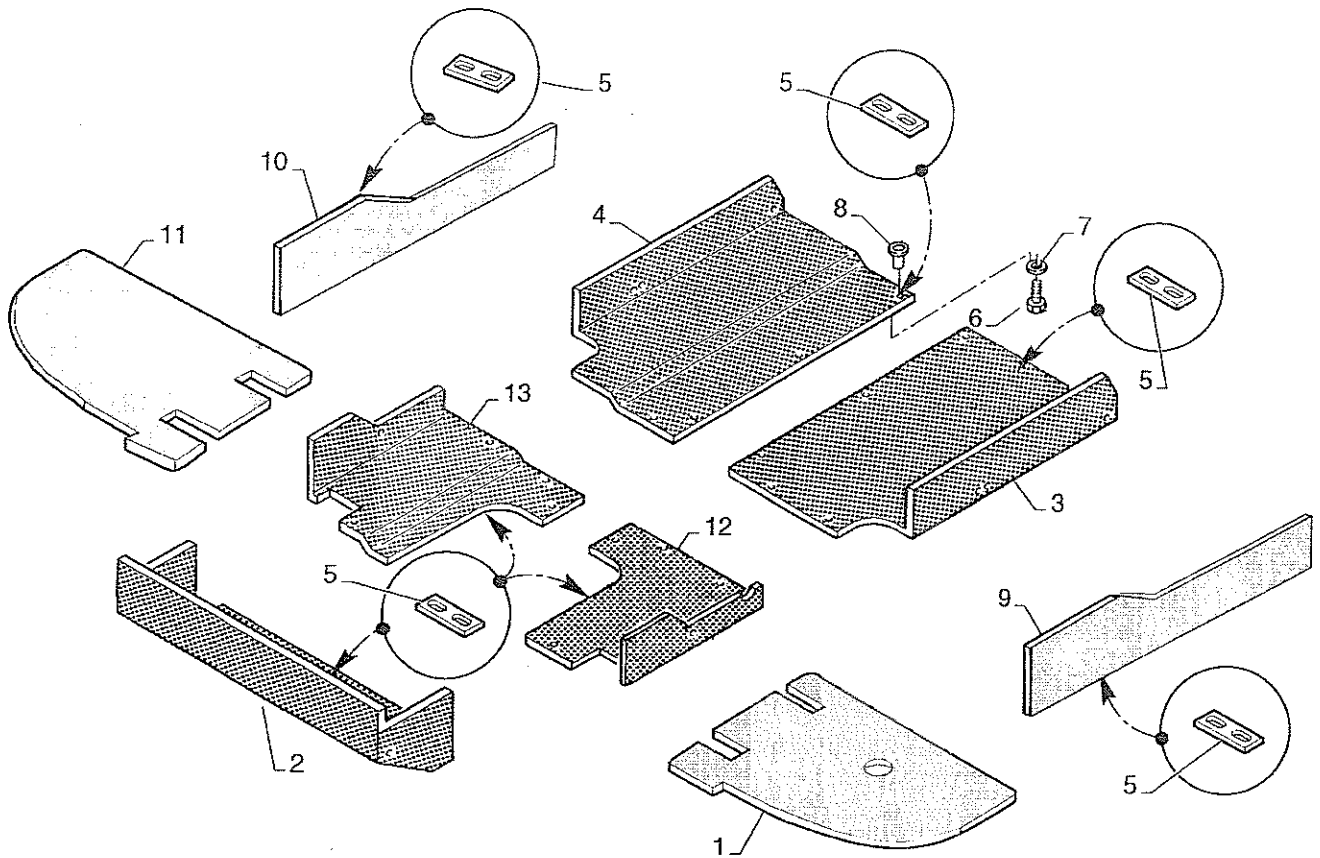

N. Pos.	COD.	DENOMINAZIONE	Q.ty	DESCRIPTION	Da matricola Serial number
1	91P4031	Pannello orizzontale base sinistra	1	Panel	200001
2	91P4020	Assieme pannello anteriore	1	Panel Assy	200001
3	90P4053	Assieme pannello posteriore sinistro	1	Panel Assy	200001
4	90P4054	Assieme pannello posteriore destro	1	Panel Assy	200001
5	90P4019	Piastrina fissaggio pannelli	-	Plate	200001
6	201011	Vite M 6x16 UNI 5739-65 per fissaggio pannelli	-	Bolt	200001
7	203002	Rondella elastica 6x18x1,6 per fissaggio pannelli	-	Washer	200001
8	90P4070	Bussola filettata M6 0917-26 per fissag. pannelli	-	Bush	200001
9	91P4018	Pannello superiore sinistro	1	Panel	200001
10	91P4017	Pannello superiore destro	1	Panel	200001
11	91P4030	Pannello base destro	1	Panel	200001
12	90P4051	Pannello intermedio destro	1	Panel	200001
13	90P4052	Pannello intermedio destro	1	Panel	200001

Minuterie tipo	Pannello codice						
	90P4054	90P4053	90P4052	90P4051	91P4017	91P4018	91P4020
201011	7	7	4	4	2	2	2
203002	7	7	4	4	2	2	2
90P4070	1	7	4	4	2	2	2
90P4019	8	8	8	8	8	-	-

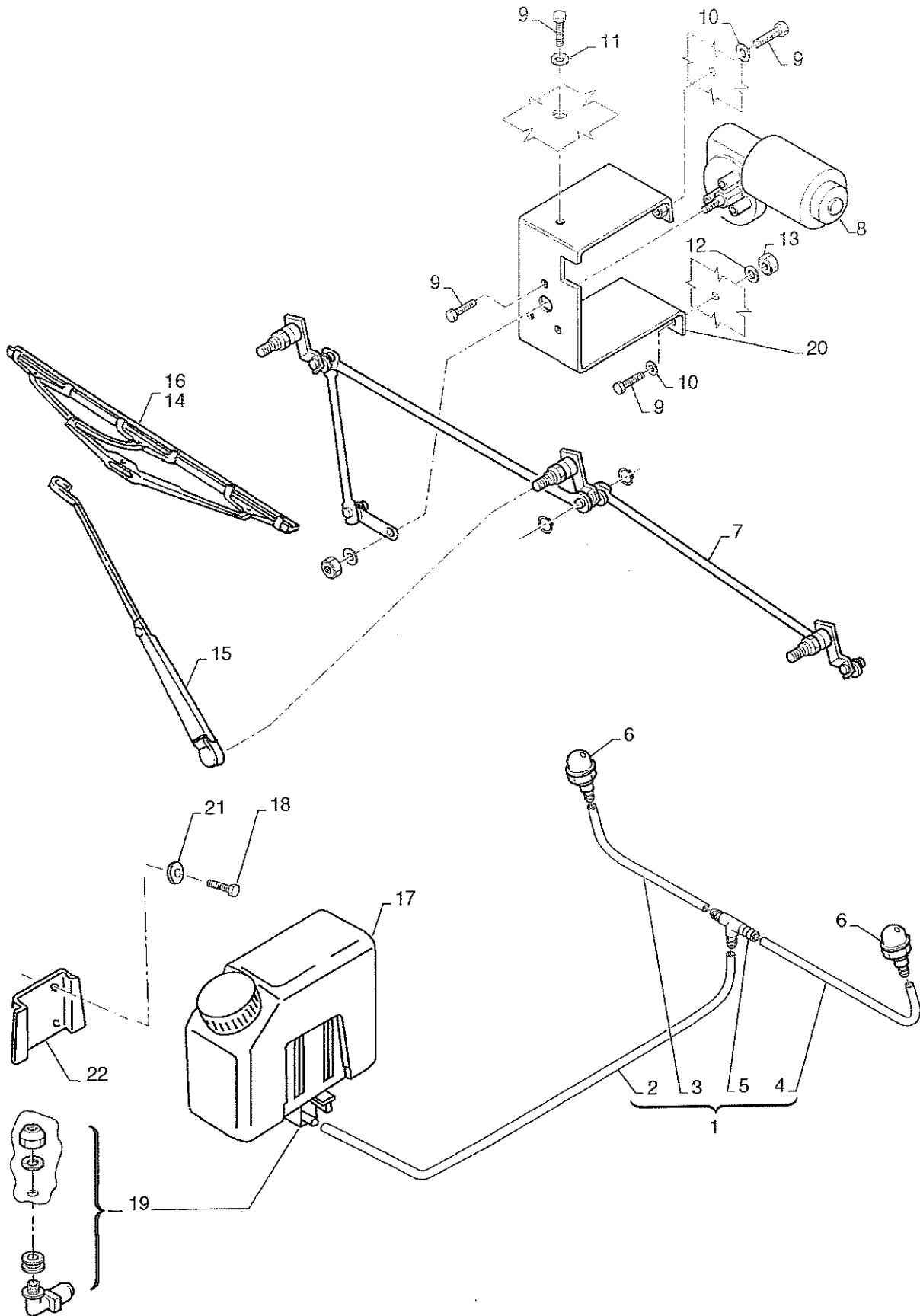

<input type="checkbox"/> 35 <input type="checkbox"/> 45	<input type="checkbox"/> TUR <input type="checkbox"/> E3	<input type="checkbox"/> 20	<input type="checkbox"/> 4x4	<input type="checkbox"/> <input type="checkbox"/>	<input type="checkbox"/> <input type="checkbox"/>	CEE <input type="checkbox"/>	<input type="checkbox"/> <input type="checkbox"/>	<input type="checkbox"/> <input type="checkbox"/>	<input type="checkbox"/> YES <input type="checkbox"/> NO
------------------------------------------------------------	-------------------------------------------------------------	-----------------------------	------------------------------	---------------------------------------------------	---------------------------------------------------	---------------------------------	---------------------------------------------------	---------------------------------------------------	-------------------------------------------------------------

N. Pos.	COD.	DENOMINAZIONE	Q.ty	DESCRIPTION	Da matricola Serial number
1	90P9303	Tubi acqua lavavetro	1	Pipes	200001
2	E4081	.Tubo acqua lavavetro l = 600	1	. Pipe l=1020	200001
3	E4080	.Tubo acqua lavavetro l = 200	1	. Pipe l=60	200001
4	E4082	.Tubo acqua lavavetro l =750	1	. Pipe l=630	200001
5	83462	. Connettore 3 vie tubi acqua lavavetro	1	. Connector	200001
6	83390	Spruzzatore lavavetro	2	Sprayer	200001
7	G6004	Leverismo tergicristallo	1	Lever	200001
8	90P3001	Motorino tergicristallo	1	Motor	200001
9	201022	Vite M 8x25 UNI 5739-65	8	Bolt	200001
10	203110	Rondella piatta 8x24x1,7 UNI 6593	4	Washer	200001
11	203104	Rondella piatta 8x17x1,5 UNI 6592	1	Washer	200001
12	203003	Rondella elastica 8x16x1,9	4	Washer	200001
13	202004	Dado M8 UNI 5587-68	4	Nut	200001
14	90P3005	Spazzola tergicristalli lato passeggero (L=480mm)	1	wiper	200001
15	G6001	Braccio portaspazzola tergicristallo	3	Arm	200001
16	90P3006	Spazzola tergicristallo centrale e lato autista	2	Wiper	200001
17	92P3001	Vaschetta acqua lavavetro	1	Cup	200001
18	201001	Vite M6x16 UNI 5739-65	4	Bolt	200001
19	G7003	Pompetta completa	1	Pump	200001
20	90P3004	Piastra supporto motore	1	plate	200001
21	203102	Rondella piana 5x15x1,6 UNI 6953-69	4	wascher	200001
22	92P3002	Supporto vaschetta	1	Support	200001

EXTREME

**Gruppo
Group**

7 0

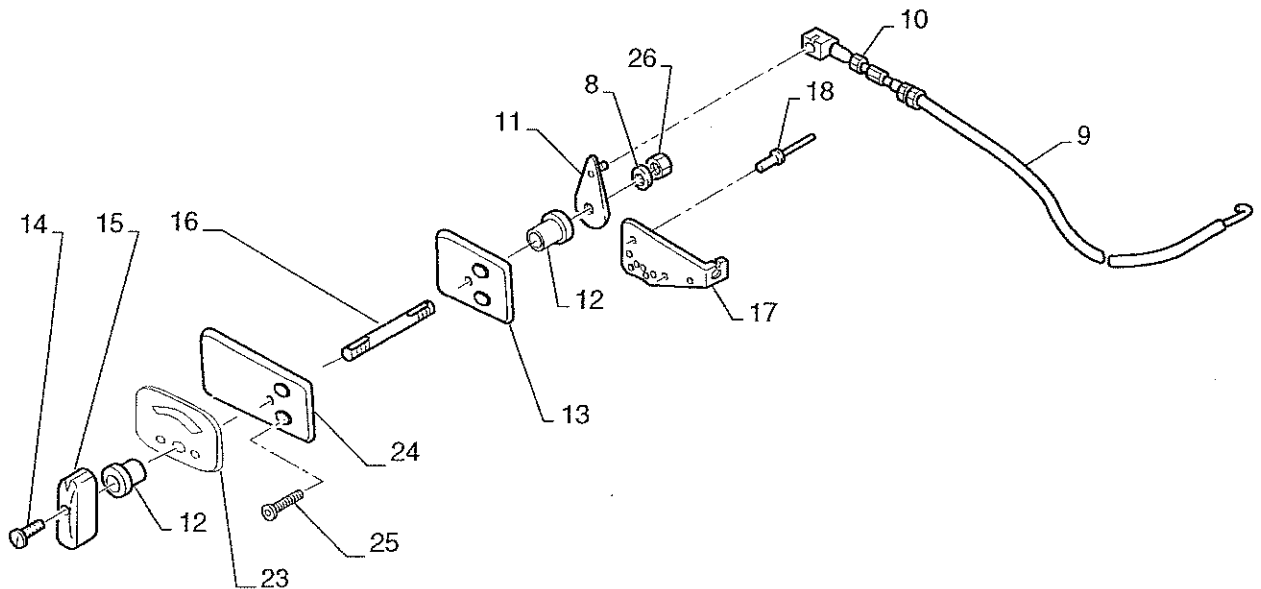
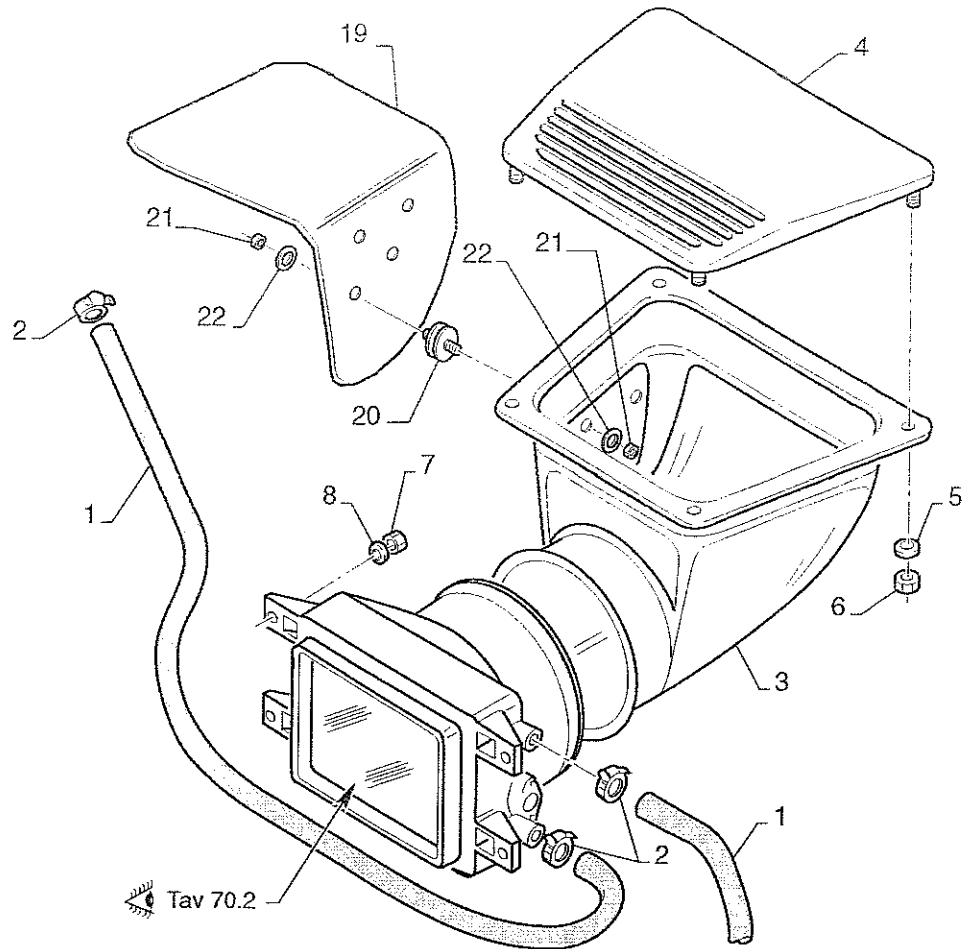

<input type="checkbox"/> 35 <input type="checkbox"/> 45	TUR <input type="checkbox"/> E3	<input type="checkbox"/> 20	<input type="checkbox"/> 4x4	<input type="checkbox"/>	<input type="checkbox"/>	<input type="checkbox"/>	CEE <input type="checkbox"/>	<input type="checkbox"/>	<input type="checkbox"/>	<input type="checkbox"/> YES <input type="checkbox"/> NO
------------------------------------------------------------	------------------------------------	-----------------------------	------------------------------	--------------------------	--------------------------	--------------------------	---------------------------------	--------------------------	--------------------------	-------------------------------------------------------------

N. Pos.	COD.	DENOMINAZIONE	Q.ty	DESCRIPTION	Da matricola Serial number
1	D8017	Tube telaio colleg. scambiatore motore e ritorno	2	Pipe	200001
2	90H2014	Fascetta	4	Clamp	200001
3	91P2001	Convogliatore aria	1	Conveyor	200001
4	90P2001	Griglia presa d'aria sul cofano	1	Grill	200001
5	203102	Rondella piana 5x15x1,6	4	Washer	200001
6	202002	Dado M5 UNI 5587	4	Nut	200001
7	202003	Dado M6 UNI 5587-68	4	Nut	200001
8	203002	Rondella elastica 6x18x1,6 UNI 8836	5	Washer	200001
9	90P2011	Filo comando rubinetto scambiatore	1	Heat exchanger control cable	200001
10	202010	Dado M5 UNI 5588-65	1	Nut	200001
11	E4042	Leva attuazione comando a filo riscaldamento	1	Lever	200001
12	E4041	Bussoia per montag. manopola comando riscald.	2	Bush	200001
13	90P1641	Piastra P.E. riscaldamento lato motore	1	Plate	200001
14	201107	Vite M 4x14 UNI 5931 8.8	1	Bolt	200001
15	90P2003	Manopola	1	Knob	200001
16	90P2012	Perno	1	Pin	200001
17	90P9205	Piastra porta leva attuazione com. a filo riscald.	1	Plate	200001
18	E4095	Rivetto per fissaggio piastra porta leva 4,8x16	3	Rivet	200001
19	91H3017	Protezione termica turbina	1	protection	200001
20	E4086	Gommino	4	Rubber	200001
21	202003	Dado M6 UNI 5587-68	8	Nut	200001
22	203115	Rondella	8	Washer	200001
23	90P2010	Piastra per manopola riscaldamento	1	Plate	200001
24	90P1640	Piastra P.E. riscaldamento lato cruscotto	1	plate	200001
25	201222	Vite	2	Bolt	200001
26	202101	Dado M6 autobloc.	1	Self-locking	200001

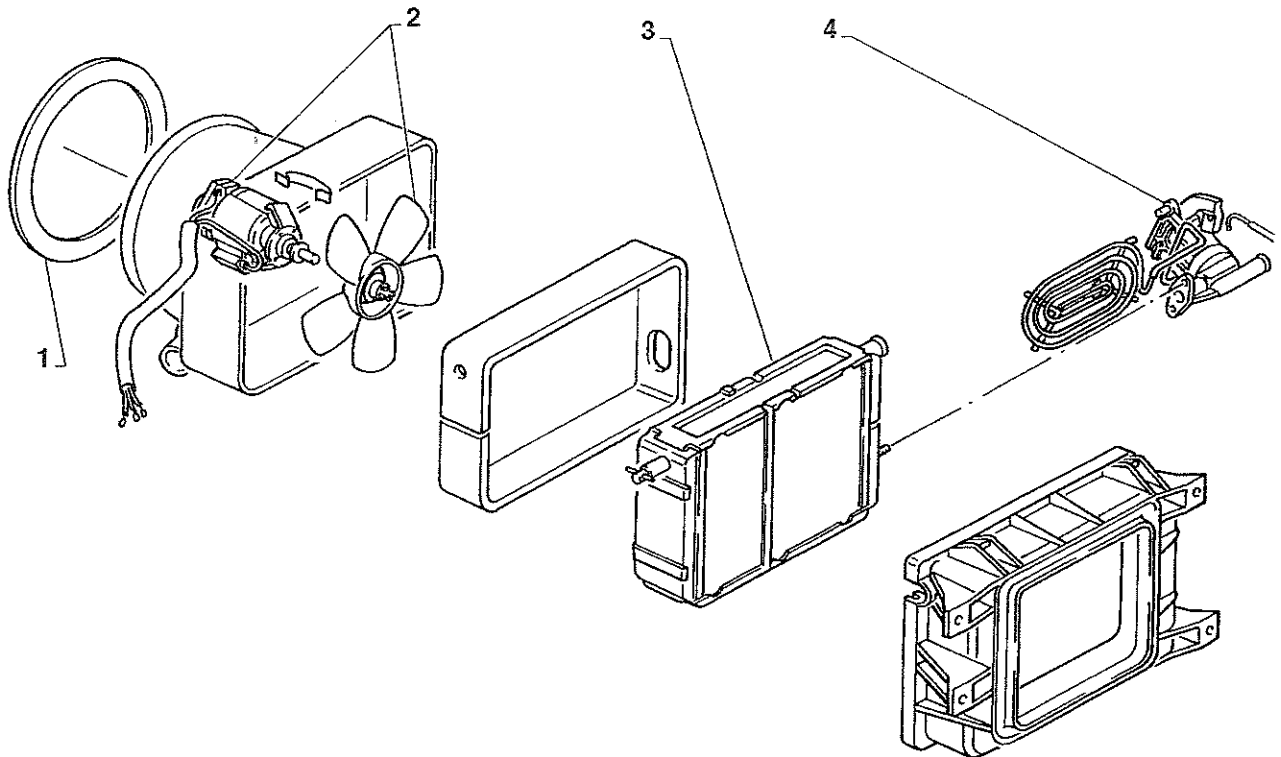

 <input type="checkbox"/> 35 <input type="checkbox"/> 45	 TUR <input type="checkbox"/> E3	 <input type="checkbox"/> 20	 <input type="checkbox"/> 4x4	 <input type="checkbox"/> <input type="checkbox"/>	 <input type="checkbox"/> <input type="checkbox"/>	 CEE <input type="checkbox"/>	 <input type="checkbox"/> <input type="checkbox"/>	 <input type="checkbox"/> <input type="checkbox"/>	 <input type="checkbox"/> YES <input type="checkbox"/> NO
------------------------------------------------------------------------------------------------------------------------------------------------	------------------------------------------------------------------------------------------------------------------------	-----------------------------------------------------------------------------------------------------------------	------------------------------------------------------------------------------------------------------------------	---------------------------------------------------------------------------------------------------------------------------------------	---------------------------------------------------------------------------------------------------------------------------------------	---------------------------------------------------------------------------------------------------------------------	-----------------------------------------------------------------------------------------------------------------------------------------	-----------------------------------------------------------------------------------------------------------------------------------------	---------------------------------------------------------------------------------------------------------------------------------------------------

BREMACH

Comandi riscaldamento - Condizionatore

Heating controls - Air conditioned

TAV. **70.2**

EXTREME Ed. 04/2002

N. Pos.	COD.	DENOMINAZIONE	Q.ty	DESCRIPTION	Da matricola Serial number
1	E4088	Guarnizione per convogliatore	1	Gasket	200001
2	G5003N	Ventola e motorino	1	Fan and motor	200001
3	G5001	Scambiatore	1	Exchange	200001
4	G5002	Rubinetto	1	Cock	200001

EXTREME

**Gruppo
Group**

80

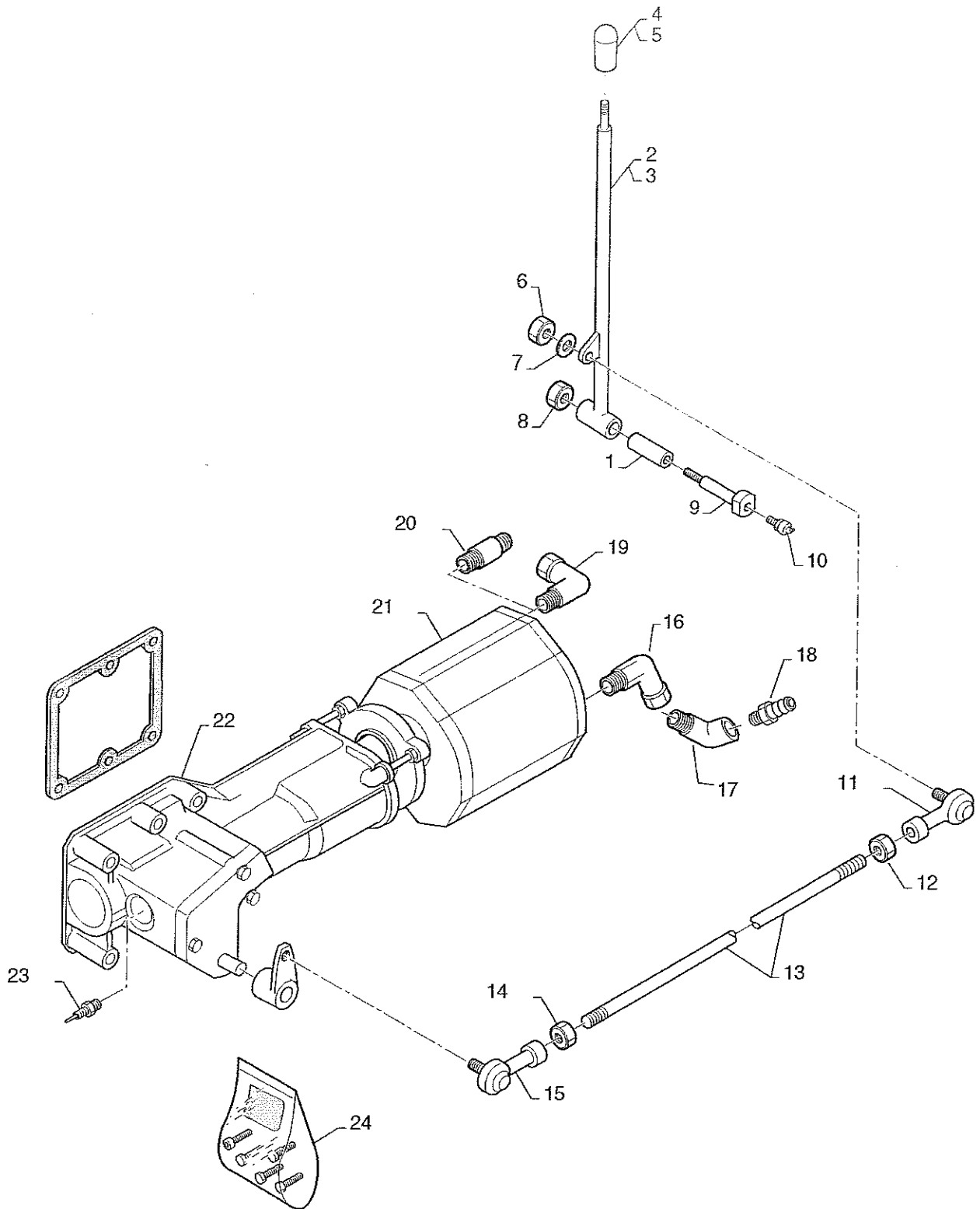

BREMACHComando di presa di forza sul cambio
Power take-off control on the gearboxTAV. **80.11**

EXTREME Ed. 04 / 2002

N. Pos.	COD.	DENOMINAZIONE	Q.ty	DESCRIPTION	Da matricola Serial number
1	80935	Boccola 10x21x60	1	Bushing	200001
2	C7006	Leva di innesto presa di forza	1	Lever	200001
3	90L6002	Leva di innesto presa di forza (CEE)	1	Lever	200001
4	90M6001	Pomolo per leva innesto presa di forza	1	Knob	200001
5	90M6006	Pomolo per leva innesto presa di forza (CEE)	1	Knob	200001
6	202012	Dado M 8	1	Nut	200001
7	203003	Rondella elastica 8x16x1,9	1	Washer	200001
8	202103	Dado autobloccante M 10 UNI 7473	1	Self-locking nut	200001
9	80943	Spinotto	1	Connector	200001
10	D4032	Ingrassatore	1	Fitting	200001
11	83574	Snodo sx IKO asta rinvio comando presa di forza	1	Joint	200001
12	83372	Dado M 8 sinistro per snodo sinistro	1	Nut	200001
13	C7005	Asta rinvio comando presa di forza	1	Rod	200001
14	202004	Dado M 8 UNI 5587-68	1	Nut	200001
15	83573	Snodo dx IKO asta rinvio comando presa di forza	1	Joint	200001
16	H5123	Gomito 3/4" zincato	1	Elbow	200001
17	H5129	Curva 3/4" 45° zincato	1	Elbow	200001
18	C7009	Porta gomma 3/4"	1	Pipe union	200001
19	90M1023	Raccordo 1/2" a 90°	1	Union	200001
20	90M4007	Raccordo 1/2" Diritto(CEE)	1	Union	200001
21	90M6003	Pompa olio LTA 325 00093	1	Pump	200001
22	91M6002	Presa di forza al cambio	1	Gear box poller takeoff	200001
23	90I1049	Microsegnalatore presa di forza (CEE)	1	Power takeoff micro switch	200001
24	90M0601	Kit viti e guarnizioni	1	Bolt and gasket kit	200001

TAV. **80.121**

Presca di forza posteriore sul riduttore con pompa idraulica

EXTREME Ed. 04 / 2002

Rear power take-off on reduction gear with hydraulic pump

BREMACH

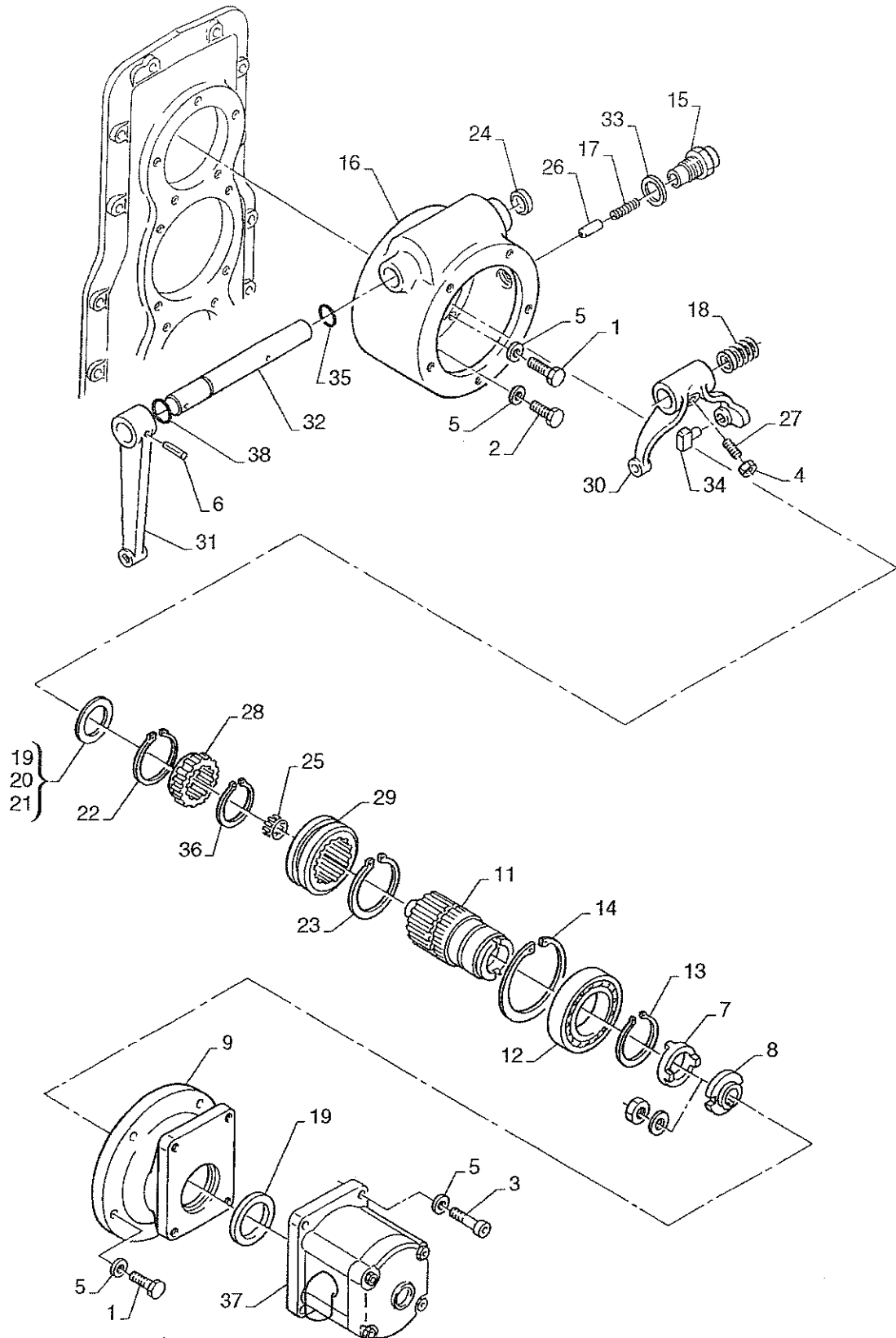

BREMACH

Rear power take-off on reduction gear with hydraulic pump

N. Pos.	COD.	DENOMINAZIONE	Q.ty	DESCRIPTION	Da matricola Serial number
1	201022	Vite	8	Screw	200001
2	201027	Vite	2	Screw	200001
3	201156	Vite	4	Screw	200001
4	202102	Dado	1	Nut	200001
5	203003	Rondella	14	Washer	200001
6	80677	Spina	1	Pin	200001
7	83653	Giunto	1	Joint	200001
8	83654	Giunto	1	Joint	200001
9	90K1001	Flangia	1	Flange	200001
10	90K3003	Anello di centraggio	1	Locating ring	200001
11	90K3004	Albero	1	Shaft	200001
12	90K3005	Cuscinetto	1	Bearing	200001
13	90K3006	Seeger	1	Seeger	200001
14	90K3007	Seeger	1	Seeger	200001
15	90R1002	Perno	1	Pin	200001
16	90R1011	Corpo	1	Body	200001
17	90R1017	Molla	1	Spring	200001
18	90R1019	Molla	1	Spring	200001
19	90R1032	Rasamento	—	Adjusting shim	200001
20	90R1020	Rasamento	—	Adjusting shim	200001
21	90R1021	Rasamento	—	Adjusting shim	200001
22	90R1031	Seeger	1	Seeger	200001
23	90R1034	Seeger	1	Seeger	200001
24	90R1035	Tappo	1	Plug	200001
25	90R1037	Gabbia a rulli	1	Roller cage	200001
26	90R1047	Nottolino	1	Pawl	200001
27	90R1048	Grano	1	Dowel	200001
28	90R1050	Mozzo di innesto	1	Hub	200001
29	90R1052	Manicotto scorrevole	1	Sleeding sleeve	200001
30	90R1054	Forcella	1	Forked shaft	200001
31	90R1055	Leva	1	Lever	200001
32	90R1058	Albero	1	Shaft	200001
33	90R1079	Guarnizione	1	Gasket	200001
34	A2017	Farfalla	2	Butterfly nut	200001
35	A3010	Guarnizione OR	1	O-Ring gasket	200001
36	B1003	Seeger	1	Seeger	200001
37	C7501	Pompa	1	Pump	200001
38	QT1312	Anello di protezione	1	Seal	200001

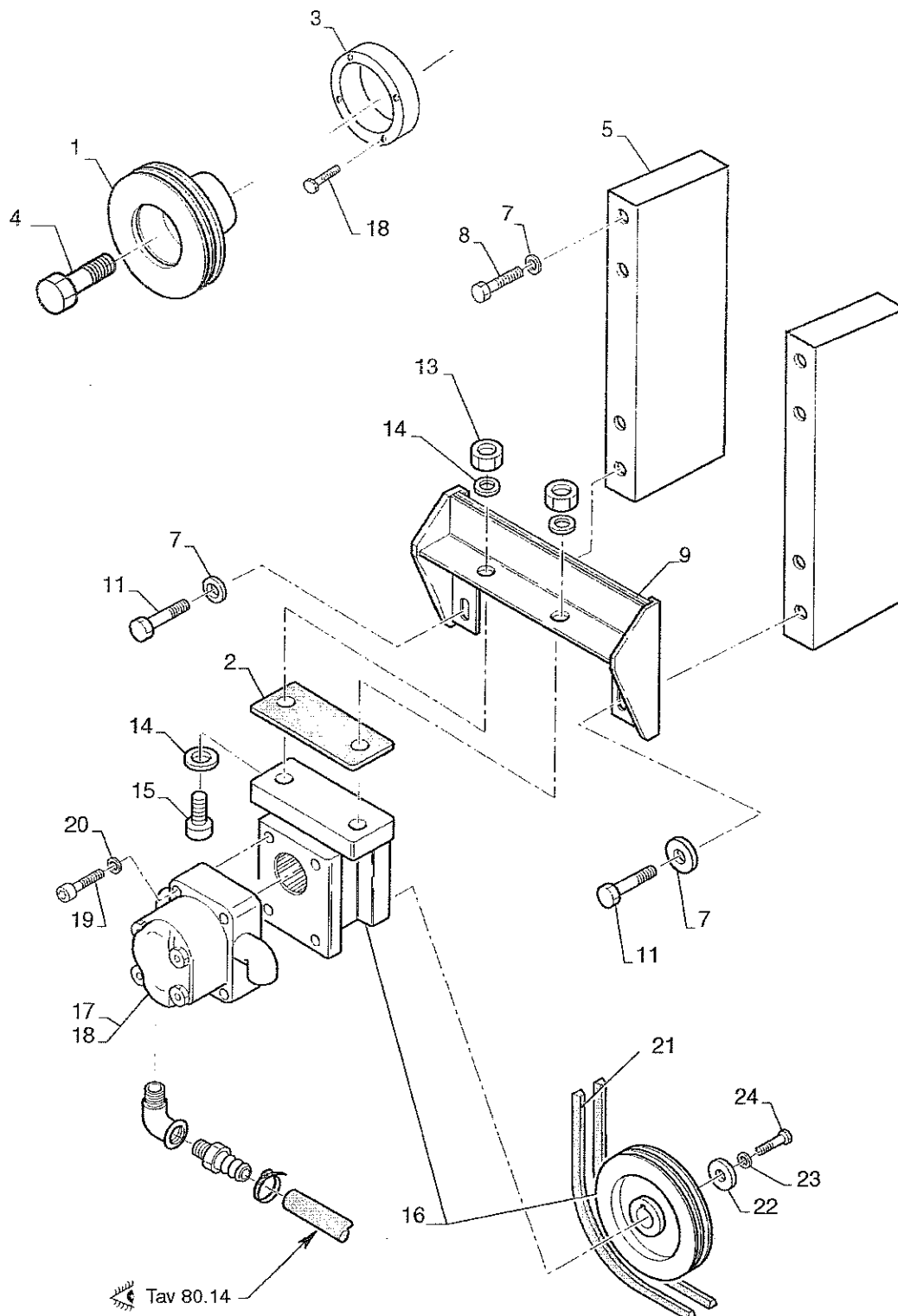

BREMACH

Presa di forza anteriore su motore

Front power take off on the engine

TAV. **80.131**

EXTREME Ed. 04 / 2002

N. Pos.	COD.	DENOMINAZIONE	Q.ty	DESCRIPTION	Da matricola Serial number
1	90K2050	Puleggia motore	1	Engine pulley	200001
2	90K2056	Gomma antivibrante	1	Gasket	200001
3	90K2051	Distanziale ventola	1	Spacer	200001
4	91H1034	Vite T.E. M20x1,5 L=73,5	1	Bolt	200001
5	90K2054	Staffa laterale	2	Bracket	200001
7	203004	Rondella	10	Washer	200001
8	211002	Vite TE parz. filet. M10x1.25 L=100	4	Bolt	200001
9	90K2033	Traversa per pompa	1	Pump cross member	200001
11	201045	Vite TE	2	Bolt	200001
13	202109	Dado M14	2	Nut	200001
14	203210	Rondella	2	Washer	200001
15	211006	Vite M14x80	2	Bolt	200001
16	90K2023	Innesto elettronico con puleggia	1	Electromagnetic gear with poule	200001
17	90K2028	Pompa 22-cc	1	Pump	200001
18	211003	Vite TE M6x35	4	Bolt	200001
19	201109	Vite TCEI	4	Bolt	200001
20	203003	Rondella	4	Washer	200001
21	90K2036	Cinghia	2	Belt	200001
22	H5107	Rondella	1	Washer	200001
23	203002	Rondella	1	Washer	200001
24	201012	Vite TE	1	Bolt	200001

BREMACHImpianto Stanley
Stanley systemTAV. **80.14**

EXTREME Ed. 04 / 2002

N. Pos.	COD.	DENOMINAZIONE	Q.ty	DESCRIPTION	Da matricola Serial number
1	201021	Vite	4	Bolt	200001
2	201054	Vite CEI M 8x55	2	Bolt	200001
3	201041	Vite	2	Bolt	200001
4	201045	Vite	3	Bolt	200001
5	202004	Dado	4	Nut	200001
6	202102	Dado	8	Nut	200001
7	202103	Dado	2	Nut	200001
8	203003	Rondella	8	Washer	200001
9	203004	Rondella	3	Washer	200001
10	203103	Rondella	8	Washer	200001
11	90K0001	Termostato	1	Thermostat	200001
12	90K1087	Attacco rapido	1	Quick union	200001
13	90K1086	Attacco rapido	1	Quick union	200001
14	K1018	Rondelle di rame	4	Washer	200001
15	K1126	Raccordo	2	Union	200001
16	90M3001	Distributore	1	Distributor	200001
17	90K1005	Prolunga	1	Extension	200001
18	90K1006	Tubo passo 2600	1	Pipe for wheelbase 2600	200001
19	90K1007	Tubo passo 3000	1	Pipe for wheelbase 3000	200001
20	C7530	Radiatore	1	Radiator	200001
21	90M4003	Tubo	1	Pipe	200001
22	90K1010	Tubo passo 2600	1	Pipe for wheelbase 2600	200001
23	90K1011	Tubo passo 3000	1	Pipe for wheelbase 3000	200001
24	90K1076	Tubo	1	Pipe	200001
25	90K1009	Tubo	1	Pipe	200001
26	90K1008	Tubo	1	Pipe	200001
27	90K1040	Tubo	1	Pipe	200001
28	90K1041	Tubo	1	Pipe	200001
29	90K1012	Cavallotto	4	U-bolt	200001
30	90K1013	Staffa destra	1	Right bracket	200001
31	90K1014	Staffa sinistra	1	Left bracket	200001
32	90K1015	Supporto	1	Support	200001
33	90K1024	Raccordo a 90°	3	Union elbow	200001
34	90K1023	Raccordo a 90°	1	Union elbow	200001
35	H5123	Raccordo a 90°	3	Union elbow	200001
36	90K1077	Raccordo a 90°	1	Union elbow	200001
37	90K1026	Raccordo a tre vie	3	3-way pipe fitting	200001
38	90K1026	Raccordo a tre vie	1	3-way pipe fitting	200001
39	90H2013	Fascetta	4	Clamp	200001
40	C7036	Portagomma	3	Pipe union	200001
41	H5114	Raccordo	1	Union	200001
42	90M4007	Raccordo 1/2" diritto	5	Union	200001
43	90K9100	Piastra	1	Plate	200001
44	90M3002	Blocco distributore elettrovalvole	1	Control valves block	200001
45	90K1027	Riduzione	1	Reduction	200001
46	C7513	Filtro	1	Filter	200001

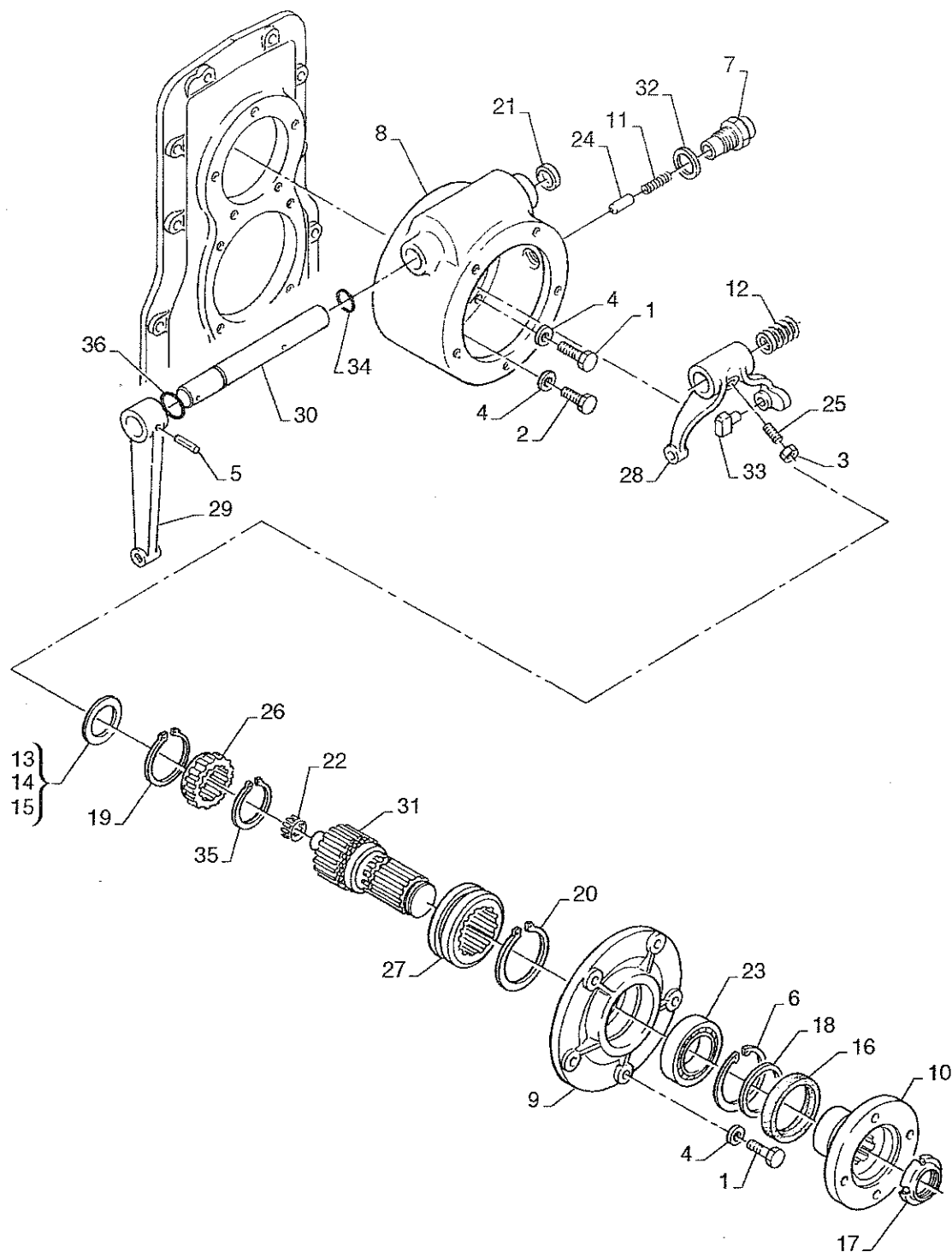

BREMACHPresa di forza posteriore su riduttore
Rear power take off on reduction gear boxTAV. **80.21**

EXTREME Ed. 04 / 2002

N. Pos.	COD.	DENOMINAZIONE	Q.ty	DESCRIPTION	Da matricola Serial number
1	201022	Vite	8	Bolt	200001
2	201027	Vite	2	Bolt	200001
3	202102	Dado	1	Nut	200001
4	203003	Rondella	10	Washer	200001
5	80677	Spina	1	Pin	200001
6	83075	Seeger	1	Seeger	200001
7	90R1002	Perno	1	Pin	200001
8	90R1011	Corpo	1	Body	200001
9	90R1012	Flangia	1	Flange	200001
10	90R1088	Flangia	1	Flange	200001
11	90R1017	Molla	1	Spring	200001
12	90R1019	Molla	1	Spring	200001
13	90R1032	Rasamento	-	Adjusting shim	200001
14	90R1020	Rasamento	-	Adjusting shim	200001
15	90R1021	Rasamento	-	Adjusting shim	200001
16	90R1024	Anello di tenuta	1	Seal ring	200001
17	90R1025	Ghiera scanalata	1	Grooved nut	200001
18	90R1026	Distanziale	1	Spacer	200001
19	90R1031	Seeger	1	Seeger	200001
20	90R1034	Seeger	1	Seeger	200001
21	90R1035	Tappo	1	Plug	200001
22	90R1037	Gabbia a rulli	1	Roller cage	200001
23	90R1044	Cuscinetto	1	Bearing	200001
24	90R1047	Nottolino	1	Pawl	200001
25	90R1048	Grano	1	Dowel	200001
26	90R1050	Mozzo di innesto	1	Hub	200001
27	90R1052	Manicotto scorrevole	1	Sleeding sleeve	200001
28	90R1054	Forcella	1	Fork	200001
29	90R1055	Leva	1	Lever	200001
30	90R1058	Albero	1	Shaft	200001
31	90R1067	Albero in uscita	1	Shaft	200001
32	90R1079	Guarnizione	1	Gasket	200001
33	A2017	Farfalla	2	Butterfly nut	200001
34	A3010	Guarnizione OR	1	O-Ring gasket	200001
35	B1003	Seeger	1	Seeger	200001
36	QT1312	Anello di protezione	1	Seal	200001

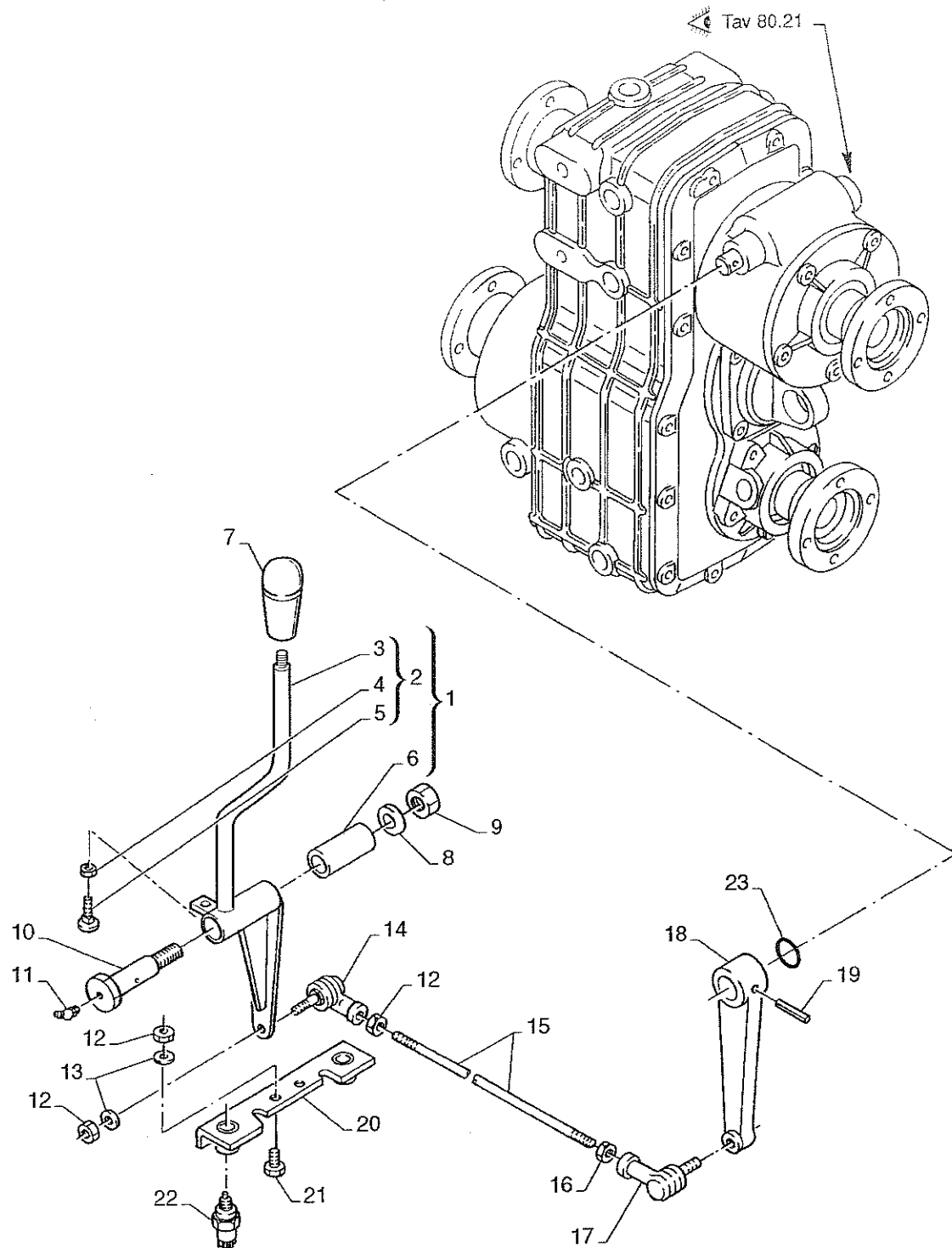

<input type="checkbox"/> 35 <input type="checkbox"/> 45	TUR <input type="checkbox"/> E3	20	4x4	<input type="checkbox"/> <input type="checkbox"/>	<input type="checkbox"/> <input type="checkbox"/>	<input type="checkbox"/> <input type="checkbox"/>	CEE <input type="checkbox"/>	<input type="checkbox"/>	<input type="checkbox"/>	<input type="checkbox"/> YES <input type="checkbox"/> NO
------------------------------------------------------------	------------------------------------	----	-----	---------------------------------------------------	---------------------------------------------------	---------------------------------------------------	---------------------------------	--------------------------	--------------------------	-------------------------------------------------------------

BREMACHComando presa di forza posteriore
Rear power take-off controlTAV. **80.22**

EXTREME Ed. 04 / 2002

N. Pos.	COD.	DENOMINAZIONE	Q.ty	DESCRIPTION	Da matricola Serial number
1	90K3010	Leva innesto presa di forza	1	Lever	200001
2	90L9601	. Leva con bussola	1	. Lever with bush	200001
3	90K3002	. . Leva	1	. . Lever	200001
4	202003	. . Dado	1	. . Nut	200001
5	201601	. . Vite	1	. . Bolt	200001
6	80934	. Boccia	1	. Bush	200001
7	90M6001	Pomolo	1	Handle	200001
8	203005	Rondella	1	Washer	200001
9	202104	Dado	1	Nut	200001
10	90L3007	Perno	1	Pin	200001
11	D4032	Ingrassatore	1	Grease nipple	200001
12	202012	Dado	4	Nut	200001
13	203003	Rondella	3	Washer	200001
14	83573	Snodo destro	1	Right joint	200001
15	90L6001	Asta	1	Rod	200001
16	83372	Dado sinistro	1	Left nut	200001
17	83574	Snodo sinistro	1	Left gauche	200001
18	90R1055	Leva	1	Lever	200001
19	80677	Spina	1	Pin	200001
20	D2004	Supporto	1	Support	200001
21	201021	Vite	2	Bolt	200001
22	F3011	Micro segnalatore	1	Microswitch	200001
23	QT1312	Anello di protezione	1	Seal	200001

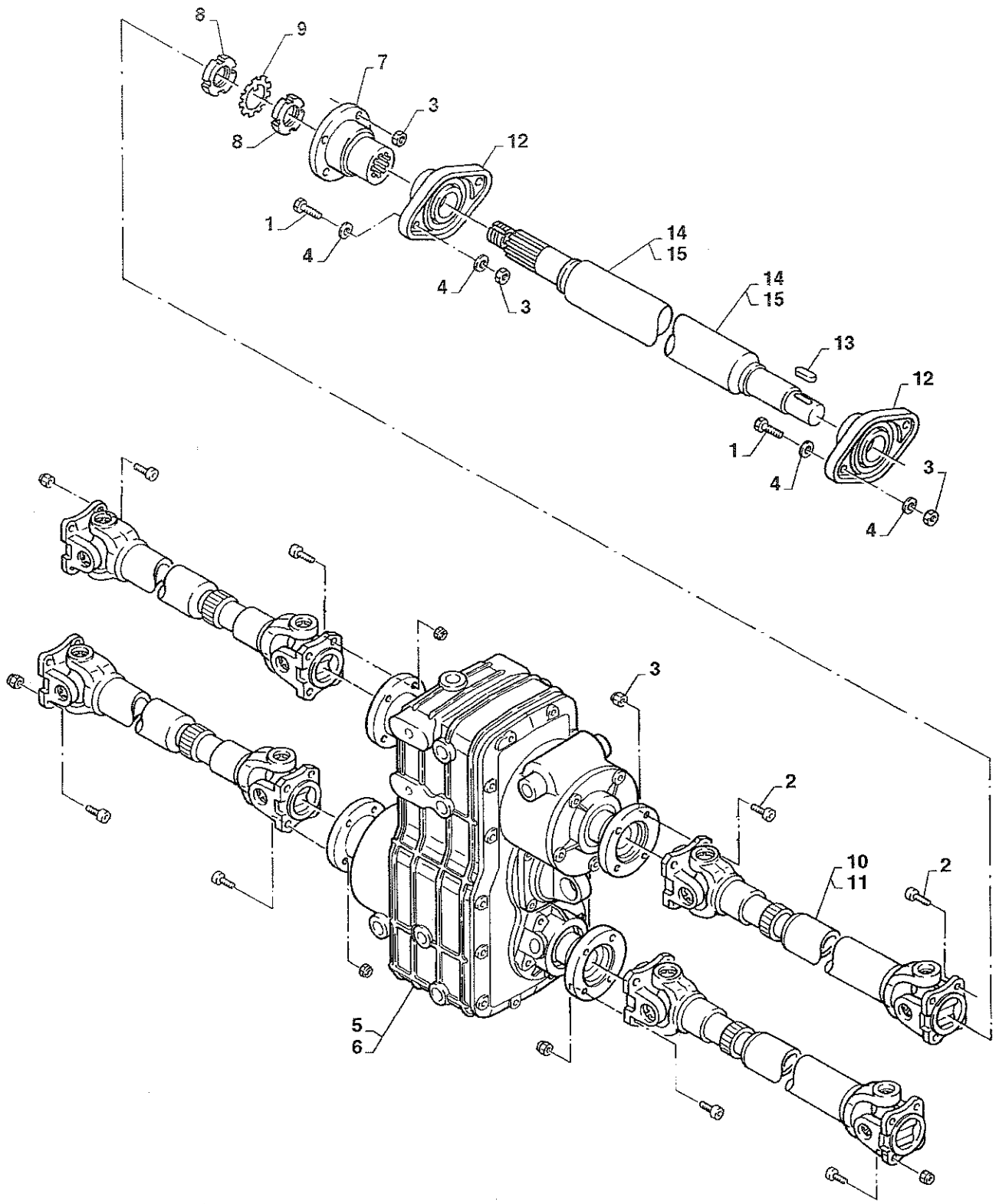

<input type="checkbox"/> 35 <input type="checkbox"/> 45	TUR <input type="checkbox"/> E3	20	<input type="checkbox"/> 4x4	<input type="checkbox"/> <input type="checkbox"/>	<input type="checkbox"/> <input type="checkbox"/>	<input type="checkbox"/> <input type="checkbox"/>	CEE <input type="checkbox"/>	<input type="checkbox"/> <input type="checkbox"/>	<input type="checkbox"/> <input type="checkbox"/>	<input type="checkbox"/> YES <input type="checkbox"/> NO
------------------------------------------------------------	------------------------------------	----	------------------------------	---------------------------------------------------	---------------------------------------------------	---------------------------------------------------	---------------------------------	---------------------------------------------------	---------------------------------------------------	-------------------------------------------------------------

BREMACHRiduttore a 20 rapporti e alberi di trasmissione
20 ratio-reduction gear and drive shaftsTAV. **80.23**

EXTREME Ed. 04 / 2002

N. Pos.	COD.	DENOMINAZIONE	Q.ty	DESCRIPTION	Da matricola Serial number
1	201038	Vite	4	Bolt	200001
2	201122	Vite	8	Bolt	200001
3	202103	Dado	8	Nut	200001
4	203004	Rondella	8	Washer	200001
5	RIDUT00050	Riduttore 20 rapporti 4x4	1	20-ratio reduction gear 4x4	200001
7	A2005	Flangia	1	Flange	200001
8	A2040	Ghiera scanalata	2	Grooved nut	200001
9	A2041	Rosetta di sicurezza	1	Spring washer	200001
10	A4001	Albero cardanico	1	Propeller shaft	200001
11	A4101	Albero cardanico	1	Propeller shaft	200001
12	A4002	Supporti	2	Supports	200001
13	A4003	Linguetta	1	Tongue	200001
14	90K3008	Albero presa di forza posteriore	1	Shaft	200001
15	90K3009	Albero presa di forza post. per serbatoio 680 mm	1	Shaft	200001

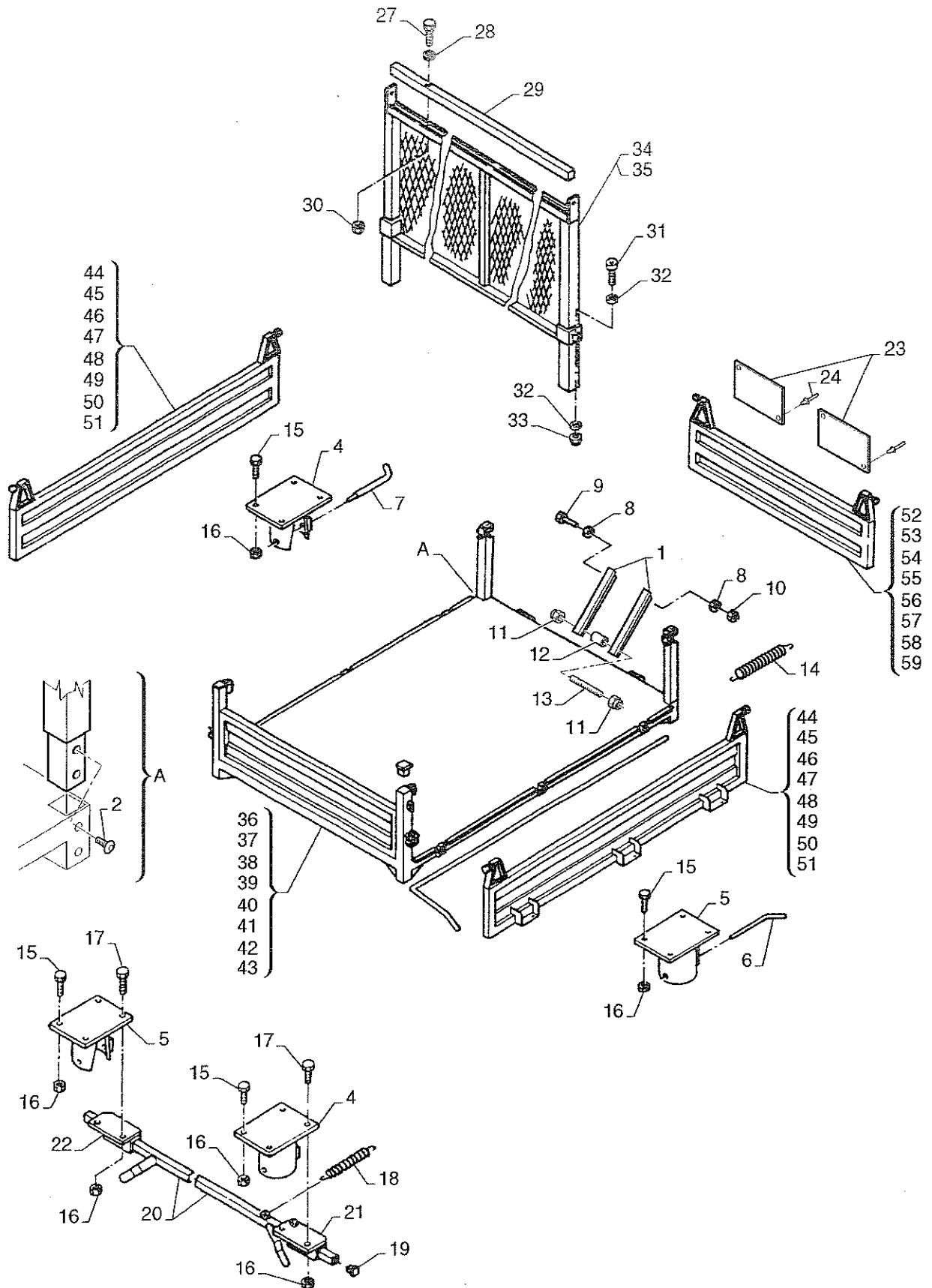

<input type="checkbox"/> 35 <input type="checkbox"/> 45	TUR <input type="checkbox"/> E3 <input type="checkbox"/>	<input type="checkbox"/> 20 <input type="checkbox"/>	4x4 <input type="checkbox"/>	<input type="checkbox"/> <input type="checkbox"/>	<input type="checkbox"/> <input type="checkbox"/>	CEE <input type="checkbox"/>	<input type="checkbox"/> <input type="checkbox"/>	<input type="checkbox"/> <input type="checkbox"/>	<input type="checkbox"/> YES <input type="checkbox"/> NO
------------------------------------------------------------	-------------------------------------------------------------	------------------------------------------------------	------------------------------	---------------------------------------------------	---------------------------------------------------	------------------------------	---------------------------------------------------	---------------------------------------------------	-------------------------------------------------------------

N. Pos.	COD.	DENOMINAZIONE	Q.ty	DESCRIPTION	Da matricola Serial number
1	C8020	Staffa	2	Bracket	200001
2	201606	Vite	4	Bolt	200001
4	C8033	Supporto posteriore destro/anteriore sinistro	2	Right/left support (rear/front)	200001
5	C8034	Supporto posteriore sinistro/anteriore destro	1	Left/right support (rear/front)	200001
6	C8037	Spina (16 mm)	1	Pin (16 mm)	200001
7	C8038	Spina (14-18 mm)	1	Pin (14-18 mm)	200001
8	203103	Rondella piatta 8x15x1,5	2	Washer	200001
9	201034	Vite TE	1	Bolt	200001
10	202004	Dado M8	1	Nut	200001
11	202104	Dado M12 autobloccante	2	Self-locking nut	200001
12	C8029	Bussola sgancio sponda posteriore	1	Bush	200001
13	C8018	Perno	1	Pin	200001
14	81322	Molla	1	Spring	200001
15	201041	Vite M 10x25	12	Bolt	200001
16	202103	Dado M10 autobloccante	16	Self-locking nut	200001
17	201042	Vite M 10x30	4	Bolt	200001
18	81863	Molla	1	Spring	200001
19	90M1323	Tappo	2	Plug	200001
20	90M1322	Tubolare di collegamento	1	Connection pipe	200001
21	90M1320	Squadretta sinistra	1	Left braket	200001
22	90M1321	Squadretta destra	1	Right braket	200001
23	90T1700	Coppia pannelli riflettenti	1	Double panel	200001
24	89544	Rivetto	1	Rivet	200001
27	201028	Vite TE	4	Bolt	200001
28	203003	Rondella piatta	4	Washer	200001
29	92T3014	Legno di appoggio	1	Wooden list	200001
30	202012	Dado	4	Nut	200001
31	201141	Vite TCEI	2	Bolt	200001
32	203004	Rondella	4	Washer	200001
33	202103	Dado autobloccante	2	Self-locking nut	200001
34	90T3055	Cavalletto grezzo	1	Trestle (raw)	200001
35	90T3055V	Cavalletto verniciato	1	Trestle (trated by painted)	200001
36	CASSA00071	Cassone completo grezzo cab. semplice p. 2600	1	Full kipper single cab (raw) 2600	200001
37	CASSA00124	Cassone completo grezzo cab. semplice p. 3000	1	Full kipper single cab (raw) 3000	200001
38	CASSA00095	Cassone completo grezzo doppia cab. p. 2600	1	Full kipper double cab (raw) 2600	200001
39	CASSA00100	Cassone completo grezzo doppia cab. p. 3000	1	Full kipper double cab (raw) 3000	200001
40		Cassone completo verniciato cab. semplice p. 2600	1	Full kipper single cab (painted) 2600	200001
41		Cassone completo verniciato cab. semplice p. 3000	1	Full kipper single cab (painted) 3000	200001
42		Cassone completo verniciato doppia cab. p. 2600	1	Full kipper double cab (painted) 2600	200001
43		Cassone completo verniciato doppia cab. p. 3000	1	Full kipper double cab (painted) 3000	200001
44	90M1313	Sponde lat. grezze cabina semplice p. 2600	2	Side board single cab (raw) 2600	200001
45	90M1318	Sponde lat. grezze cabina semplice p. 3000	2	Side board single cab (raw) 3000	200001
46	90M1314	Sponde lat. grezze doppia cabina p. 2600	2	Side board double cab (raw) 2600	200001
47	90M1312	Sponde lat. grezze doppia cabina p. 3000	2	Side board double cab (raw) 3000	200001
48	90M1313V	Sponde lat. verniciate cabina semplice p. 2600	2	Side board single cab (painted) 2600	200001
49	90M1318V	Sponde lat. verniciate cabina semplice p. 3000	2	Side board single cab (painted) 3000	200001
50	90M1314V	Sponde lat. verniciate doppia cabina p. 2600	2	Side board double cab (painted) 2600	200001
51	90M1312V	Sponde lat. verniciate doppia cabina p. 3000	2	Side board double cab (painted) 3000	200001
52	90M1355	Sponda post. grezza cabina semplice p. 2600	1	Tailgate single cab (raw) 2600	200001
53	90M1355	Sponda post. grezza cabina semplice p. 3000	1	Tailgate single cab (raw) 3000	200001
54	90M1355	Sponda post. grezza doppia cabina p. 2600	1	Tailgate double cab (raw) 2600	200001
55	90M1355	Sponda post. grezza doppia cabina p. 3000	1	Tailgate double cab (raw) 3000	200001
56	90M1355V	Sponda post. verniciata cabina semplice p. 2600	1	Tailgate single cab (painted) 2600	200001
57	90M1355V	Sponda post. verniciata cabina semplice p. 3000	1	Tailgate single cab (painted) 3000	200001
58	90M1355V	Sponda post. verniciata doppia cabina p. 2600	1	Tailgate double cab (painted) 2600	200001
59	90M1355V	Sponda post. verniciata doppia cabina p. 3000	1	Tailgate double cab (painted) 3000	200001

Codici in bianco : da richiedere al magazzino ricambi prima di inviare l'ordine.

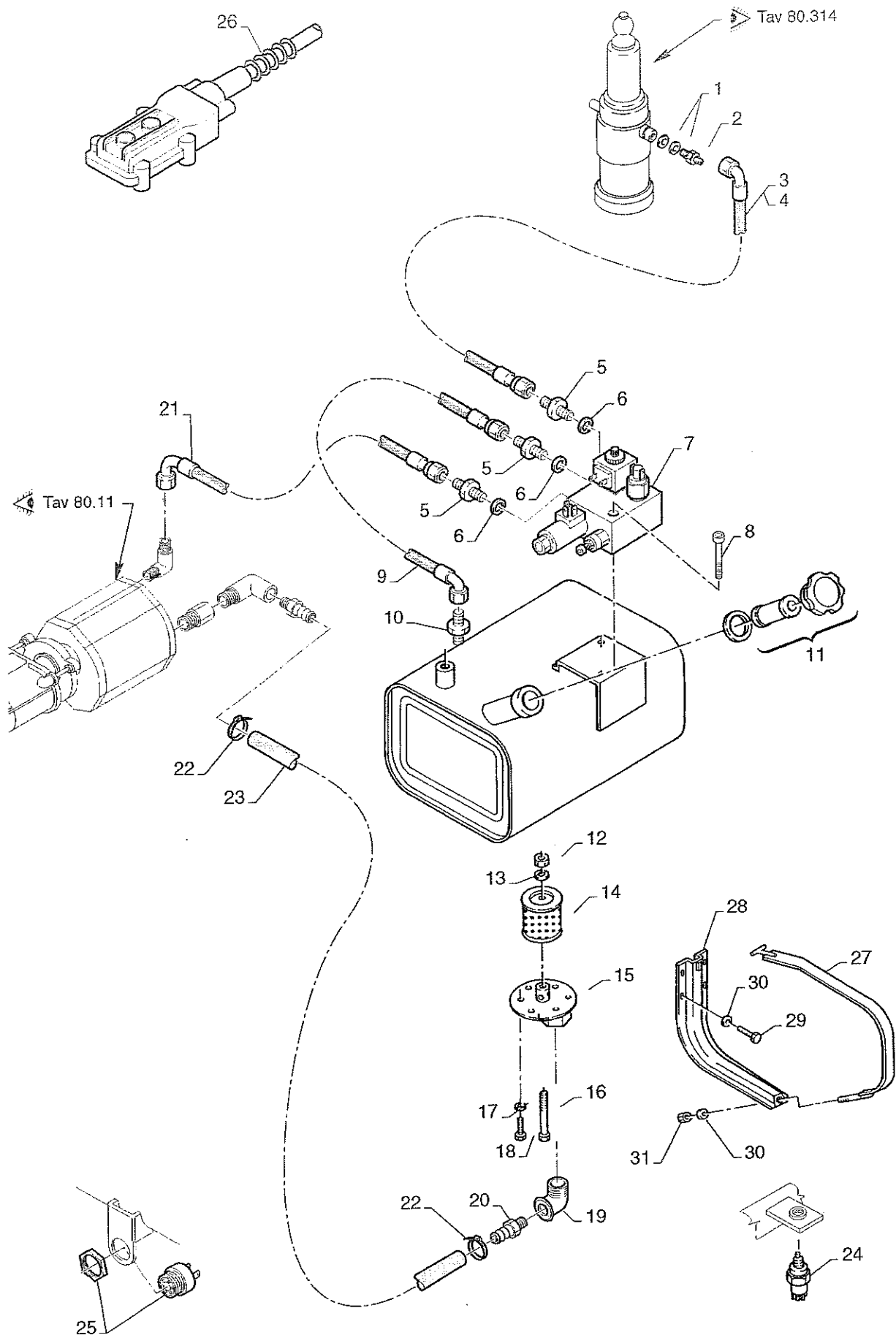

<input type="checkbox"/> 35 <input type="checkbox"/> 45	TUR E3 <input type="checkbox"/>	20 <input type="checkbox"/>	4x4 <input type="checkbox"/>	<input type="checkbox"/>	<input type="checkbox"/>	<input type="checkbox"/>	CEE <input type="checkbox"/>	<input type="checkbox"/>	<input type="checkbox"/>	<input type="checkbox"/>	<input type="checkbox"/> YES <input type="checkbox"/> NO
------------------------------------------------------------	------------------------------------	-----------------------------	------------------------------	--------------------------	--------------------------	--------------------------	------------------------------	--------------------------	--------------------------	--------------------------	-------------------------------------------------------------

BREMACH

Dump assy (hydraulic connections)

EXTREME Ed. 04 / 2002

N. Pos.	COD.	DENOMINAZIONE	Q.ty	DESCRIPTION	Da matricola Serial number
1	C7038	O-Ring 128	2	O-Ring	200001
2	C7037	Raccordo idraulico	1	Union	200001
3	90M4004	Tubo idraulico blocco elettrovalvola attuatore p. 2600	1	Pipe	200001
4	90M4005	Tubo idraulico blocco elettrovalvola attuatore p. 3000	1	Pipe	200001
5	90M4007	Raccordo 1/2" diritto	3	Union	200001
6	K1018	Guarnizione rame 1/2"	3	Gasket	200001
7	90M3002	Blocco distributore elettrovalvole senza pressostato	1	Control valves block	200001
8	201154	Vite CEI M 8x55	2	Bolt	200001
9	90M4006	Tubo idraulico blocco elettrovalvole serbatoio olio	1	Pipe	200001
10	90M4009	Raccordo 3/4" diritto	1	Union	200001
11	83823	Tappo e filtro di carico per serbatoio olio	1	Pipe	200001
12	202102	Dado M 8 autobloccante	1	Nut	200001
13	203110	Rondella piana 8x24x1,7	1	Washer	200001
14	C7014	Filtro in aspirazione	1	Filter	200001
15	C7013	Flangia aspirazione	1	Flange	200001
16	201031	Vite M 8x70 UNI 5737-65	1	Bolt	200001
17	203001	Rondella elastica 6x12x1,4	6	Washer	200001
18	201012	Vite M 6x20	6	Bolt	200001
19	90M3005	Raccordo a 90°	1	Union	200001
20	90M3006	Portagomma ottone "1"	1	Pipe union	200001
21	90M4003	Tubo idraulico	1	Pipe	200001
22	90H2013	Fascetta	2	Clamp	200001
23	90M4003	Tubo idraulico	1	Pipe	200001
24	F3011	Micro interruttore per ribaltabile	1	Microswitch	200001
25	90M3502	Cicalina ribaltabile	1	Tilting kipper beeper	200001
26	90M3503	Pulsantiera per comando ribaltabile	1	Tilting kipper control box	200001
27	84056	Fascia fissaggio serbatoio	2	Bracket	200001
28	84053	Staffa sostegno serbatoio	2	Bracket	200001
29	201020	Vite M 8x16	8	Bolt	200001
30	203003	Rondella elastica 8x16x1,9	10	Washer	200001
31	202004	Dado M 8 UNI 5527	2	Nut	200001

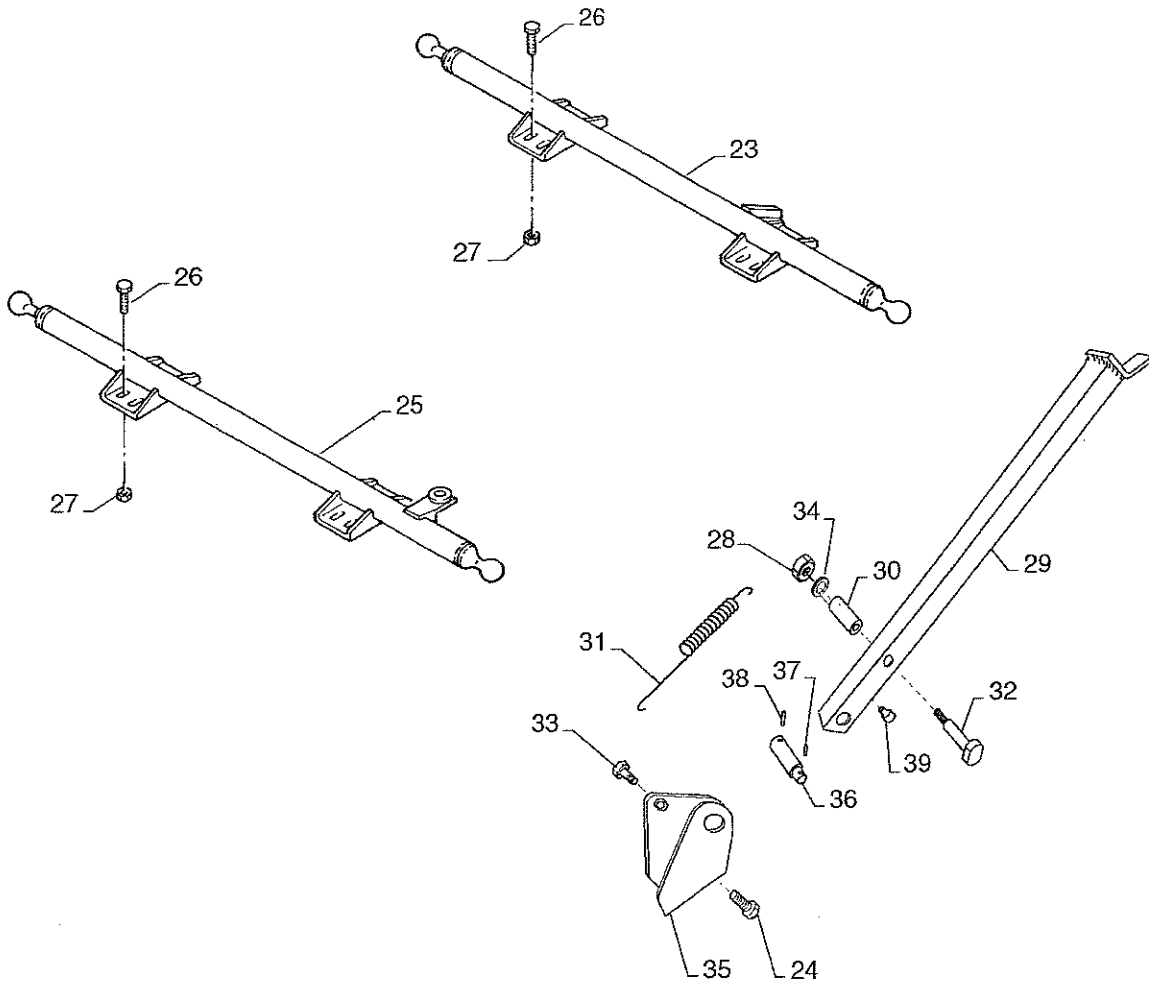
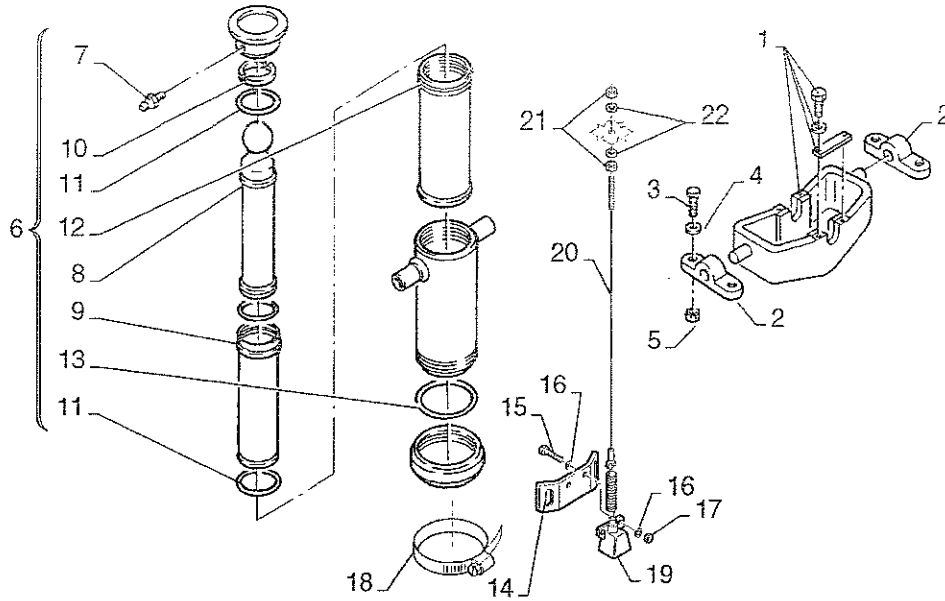

BREMACHPistone e traverse del ribaltabile
Piston and cross members of the tipperTAV. **80.314**

EXTREME Ed. 04 / 2002

N. Pos.	COD.	DENOMINAZIONE	Q.ty	DESCRIPTION	Da matricola Serial number
1	C7034	Culla pistone attuatore	1	Jack support	200001
2	C7035	Supporto mozzo	2	Support	200001
3	201051	Vite M 12x40	4	Bolt	200001
4	203005	Rondella elastica 12x24x2,8	4	Washer	200001
5	202006	Dado M12	4	Nut	200001
6	C6000	Pistone attuatore completo	1	Piston	200001
7	83375	. Ingrassatore M 6x1	1	. Fitting	200001
8	C6002	. Guarnizione TSE 61/69	1	. Gasket	200001
9	C6003	. Guarnizione TSE 76/84	1	. Gasket	200001
10	C8007	. Semiguscio fermo pistone	2	. Piston malf clamp	200001
11	C8006	. Seeger I 70 UNI 7437-75	2	. Seeger	200001
12	C6004	. Guarnizione TSE 91/99	1	. Gasket	200001
13	C6001	. O-Ring 4400 (101,2x3,53)	1	. O-Ring	200001
14	90M1335	Supporto sensore elettrico fondo corsa	1	Support	200001
15	201001	Vite M 5x16 UNI 5739-65	2	Bolt	200001
16	203101	Rondella piana 5x10x1	4	Washer	200001
17	202002	Dado M5 UNI 5387-68	2	Nut	200001
18	92H4007	Fascetta 108/128 H.11	1	Clamp	200001
19	90M3501	Interruttore fondo corsa a trazione	1	Switch	200001
20	90M3504	Cavo per fine corsa	1	Cable	200001
21	202002	Dado	1	Nut	200001
22	202102	Rondella	1	Washer	200001
23	C8025	Traversa posteriore ribaltabile	1	Cross brace	200001
24	201041	Vite T.E.	2	Bolt	200001
25	90M5003	Traversa anteriore ribaltabile	1	Cross brace (CEE yes)	200001
26	201041	Vite M 10x25 UNI 5739 per mont. traverse ribalt.	16	Bolt	200001
27	202103	Dado M10 autobloc. UNI 7473 per mont. traverse	16	Nut	200001
28	202102	Dado autobloccante	1	Self-locking nut	200001
29	90M1334	Staffa per ribaltabile	1	Tilting kipper bracket	200001
30	D8039	Bussola	1	Bush	200001
31	90M1332	Molla	1	Spring	200001
32	201030	Vite T.E.	1	Bolt	200001
33	K2085	Vite T.E.	1	Bolt	200001
34	203003	Rondella piatta	1	Washer	200001
35	90M1333	Supporto	1	Support	200001
36	90M1336	Perno	1	Pin	200001
37	207004	Spina	1	Pin	200001
38	207003	Spina	1	Pin	200001
39	90M1339	Gommino	1	Rubber	200001

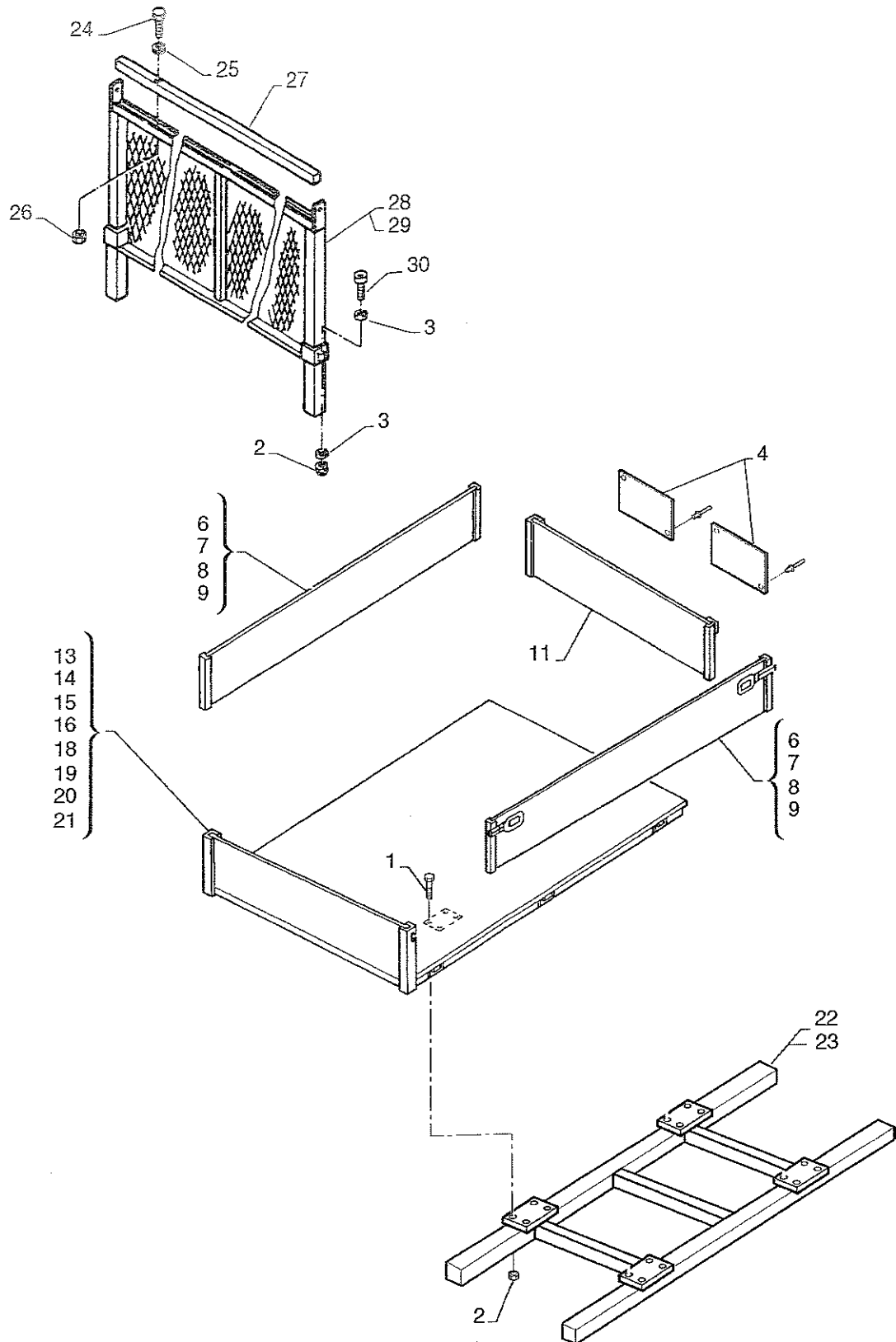

BREMACH

Cassone fisso

Fixed body

TAV.

80.32

EXTREME Ed. 04 / 2002

N. Pos.	COD.	DENOMINAZIONE	Q.ty	DESCRIPTION	Da matricola Serial number
1	201042	Vite	16	Bolt	200001
2	202103	Dado	16	Nut	200001
3	203004	Rondella	2 +	washer	200001
4	90T1700	Coppia pannelli riflettenti	1	Double panel	200001
6	90M2315	Sponda lat. cassone 2450x1770x400	2	Side board for body 2450x1770x400	200001
7	90M2316	Sponda lat. cassone 2850x1770x400	2	Side board for body 2850x1770x400	200001
8	90M2317	Sponda lat. cassone 1665x1770x400	2	Side board for body 1665x1770x400	200001
9	90M2318	Sponda lat. cassone 2065x1770x400	2	Side board for body 2065x1770x400	200001
11	90M2320	Sponda post. cassoni larghezza 1770 altezza 400	1	Tailgate for bodies 1770 wide 400 hight	200001
13	CASSA00149	Cassone fisso completo grezzo 2450x1770x400	1	Full body (raw) 2450x1770x400	200001
14	CASSA00148	Cassone fisso completo grezzo 2850x1770x400	1	Full body (raw) 2850x1770x400	200001
15	CASSA00150	Cassone fisso completo grezzo 1665x1770x400	1	Full body (raw) 1665x1770x400	200001
16	CASSA00151	Cassone fisso completo grezzo 2065x1770x400	1	Full body (raw) 2065x1770x400	200001
18		Cassone completo fisso vernic. 2450x1770x400	1	Full body (painted) 2450x1770x400	200001
19		Cassone completo fisso vernic. 2850x1770x400	1	Full body (painted) 2850x1770x400	200001
20		Cassone completo fisso vernic. 1665x1770x400	1	Full body (painted) 1665x1770x400	200001
21		Cassone completo fisso vernic. 2065x1770x400	1	Full body (painted) 2065x1770x400	200001
22	91M2301	Controtelaio passo 2450	1	Secondary chassis (2450)	200001
23	91M2300	Controtelaio passo 2850	1	Secondary chassis (2850)	200001
24	201028	Vite TE	4	Bolt	200001
25	203003	Rondella	4	Washer	200001
26	202012	Dado	4	Nut	200001
27	90T3099	Legno di appoggio	1	Wooden list	200001
28	90T3090	Cavalletto grezzo	1	Trestle (raw)	200001
29	90T3090V	Cavalletto verniciato	1	Trestle (trated by painted)	200001
30	201141	Vite TCEI	2	Bolt	200001

Codici in bianco : da richiedere al magazzino ricambi prima di inviare l'ordine.

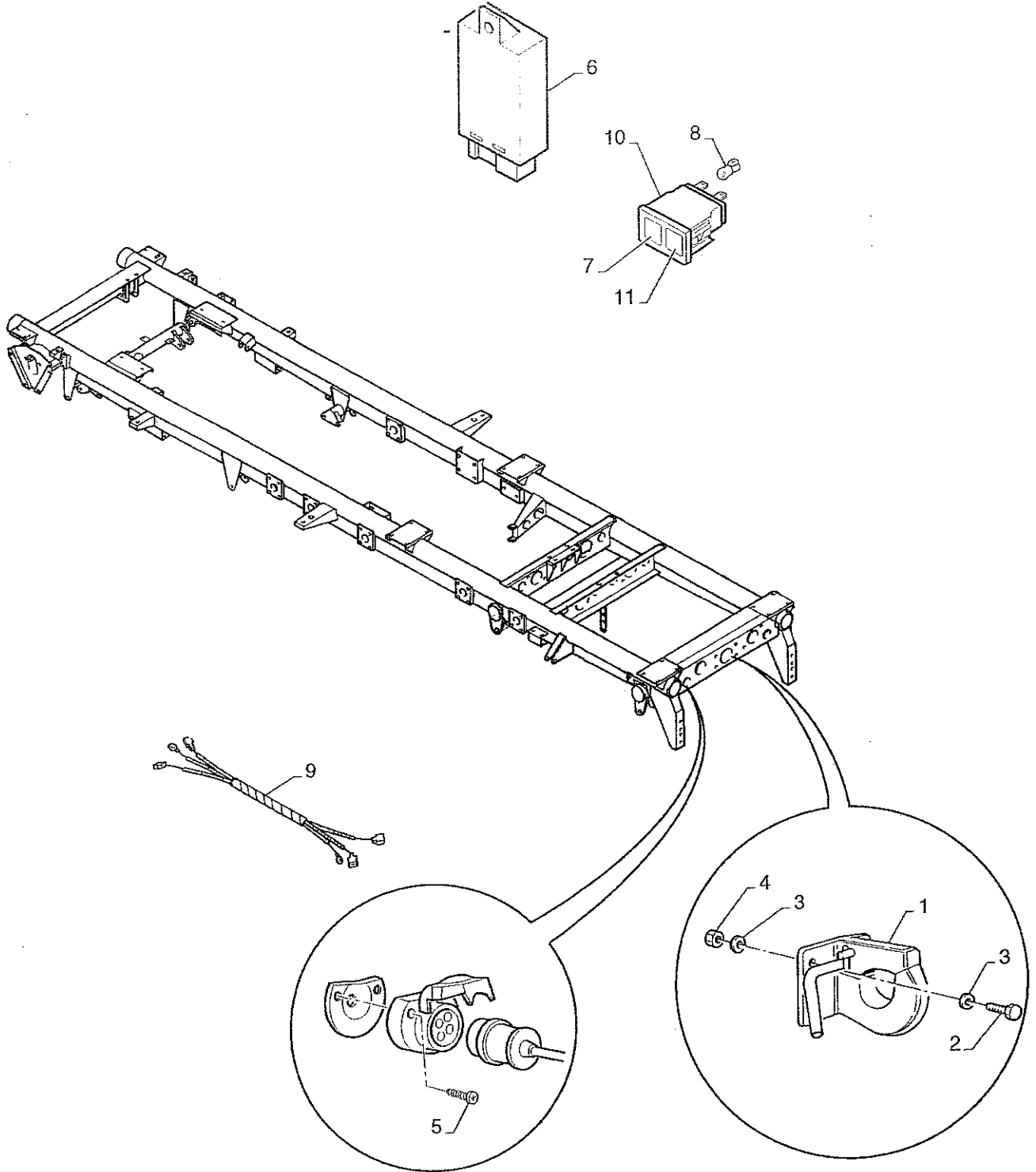

<input type="checkbox"/> 35 <input type="checkbox"/> 45	<input type="checkbox"/> TUR <input type="checkbox"/> E3	<input type="checkbox"/> 20	<input type="checkbox"/> 4x4	<input type="checkbox"/> <input type="checkbox"/>	<input type="checkbox"/> <input type="checkbox"/>	<input type="checkbox"/> <input type="checkbox"/>	CEE <input type="checkbox"/>	<input type="checkbox"/> <input type="checkbox"/>	<input type="checkbox"/> <input type="checkbox"/>	<input type="checkbox"/> YES <input type="checkbox"/> NO
------------------------------------------------------------	-------------------------------------------------------------	-----------------------------	------------------------------	---------------------------------------------------	---------------------------------------------------	---------------------------------------------------	---------------------------------	---------------------------------------------------	---------------------------------------------------	-------------------------------------------------------------

BREMACHGancio di traino
Tow hook

TAV.

80.4

EXTREME Ed. 04 / 2002

N. Pos.	COD.	DENOMINAZIONE	Q.ty	DESCRIPTION	Da matricola Serial number
1	A1028	Gancio ulpio	1	Retainer	200001
2	201064	Vite M 14x40 UNI 5739-65	4	Bolt	200001
3	213106	Rondella piana 14x28x2,5	8	Washer	200001
4	202109	Dado M 14 autobloccante	4	Nut	200001
5	201402	Vite testa croce M 5x35	3	Bolt	200001
6	I4503	Intermittenza	1	Intermittence relay	200001
7	90I1116	Vetrino per indicatore direzione rimorchio	1	Glass	200001
8	90I1030	Lampada 12V 1,2W	1	Lamp	200001
9	91I1005	Cablaggio per gancio	1	Wiring	200001
10	90I1083	Telaio porta vetrini	1	Frame	200001
11	90I1118	Vetro verde neutro	1	Glass	200001

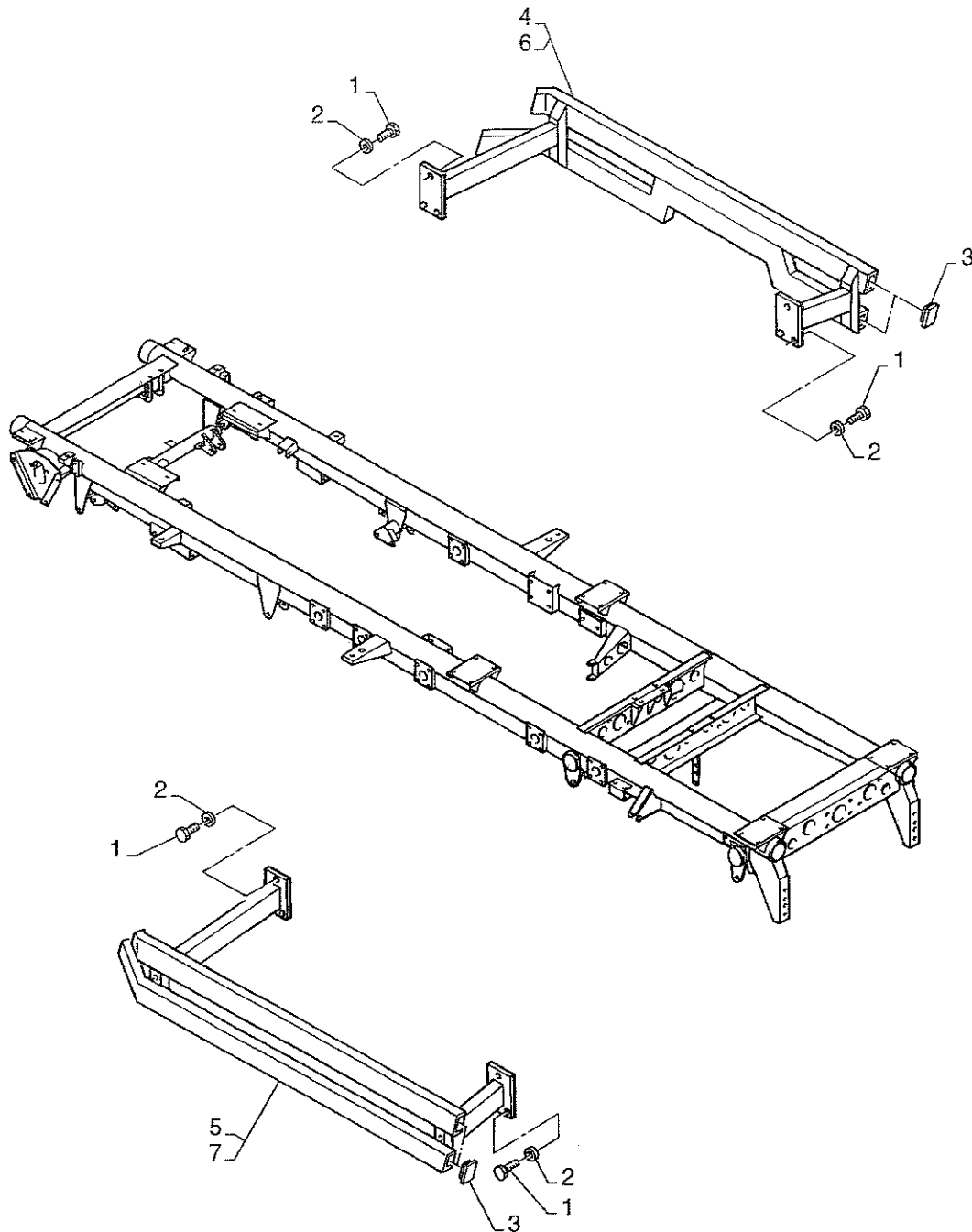

BREMACH

Barre laterali antincaastro

Lateral guard rods

TAV.

80.5

EXTREME Ed. 04 / 2002

N. Pos.	COD.	DENOMINAZIONE	Q.ty	DESCRIPTION	Da matricola Serial number
1	201020	Vite	12	Bolt	200001
2	203003	Rondella	12	Washer	200001
3	90N1009	Tappo	8	Plug	200001
4	90N1038	Protezione laterale destra passo 2600 Extreme	1	Right side guard wheelbase 2600	200001
5	90N1039	Protezione laterale sinistra passo 2600 Extreme	1	Left side guard wheelbase 2600	200001
6	90N1040	Protezione laterale destra passo 3000 Extreme	1	Right side guard wheelbase 3000	200001
7	90N1041	Protezione laterale sinistra passo 3000 Extreme	1	Left side guard wheelbase 3000	200001

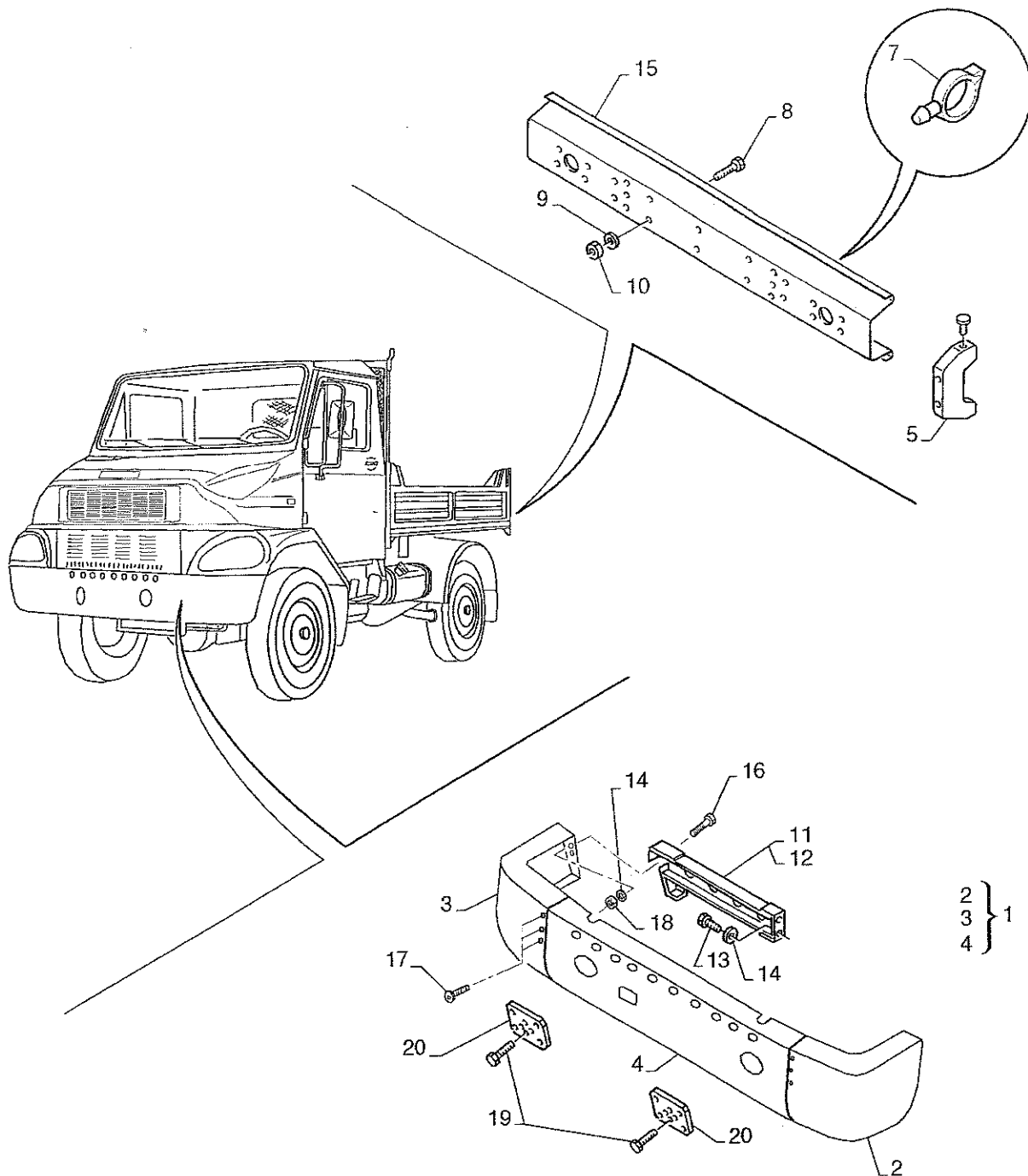

BREMACHBarra antincastro - paraurti
Anti-restraining bar-bumper

TAV.

80.6

EXTREME Ed. 04 / 2002

N. Pos.	COD.	DENOMINAZIONE	Q.ty	DESCRIPTION	Da matricola Serial number
1	90N9162	Assieme paraurti anteriore	1	Buffer	200001
2	90N1030	.Paraurti anteriore laterale sinistro	1	. Left lateral beffer	200001
3	90N1029	.Paraurti anteriore laterale destro	1	. Right lateral beffer	200001
4	90N1028	.Paraurti anteriore centrale	1	. Centre beffer	200001
5	A1048	Testata plastica barra anti incastro	2	Head	200001
6	83984	Pop per rivestimento 10008	8	Pressure rivet	200001
7	I1004	Fascetta per montaggio cablaggio elettr. luci post.	8	Clamp	200001
8	201041	Vite M 10x25	4	Bolt	200001
9	203004	Rondella elastica 10x20x2,3	4	Washer	200001
10	202005	Dado M 10 UNI 5587-68	4	Nut	200001
11	90N1004D	Staffa laterale destra sostegno paraurti anteriore	1	Bracket	200001
12	90N1004S	Staffa laterale sinistra sostegno paraurti anteriore	1	Bracket	200001
13	201020	Vite M 8x16 UNI 5739-45	4	Bolt	200001
14	203003	Rondella elastica 8x16x19	4	Washer	200001
15	90N1035	Barra anti incastro	1	Guard rod	200001
16	201021	Vite M 8x20	4	Bolt	200001
17	201606	Vite M 10x20 UNI 7380 per montaggio paraurti	4	Bolt	200001
18	202102	Dado autobloccante M 8 UNI 7473	4	Self-locking nut	200001
19	201133	Vite M 12x25 UNI 5931	8	Bolt	200001
20	B9121	Piastra per attacchi attrezzature	2	Plate	200001

2 91N 1024SV

3 91N 1024DV

4 91N 1023V

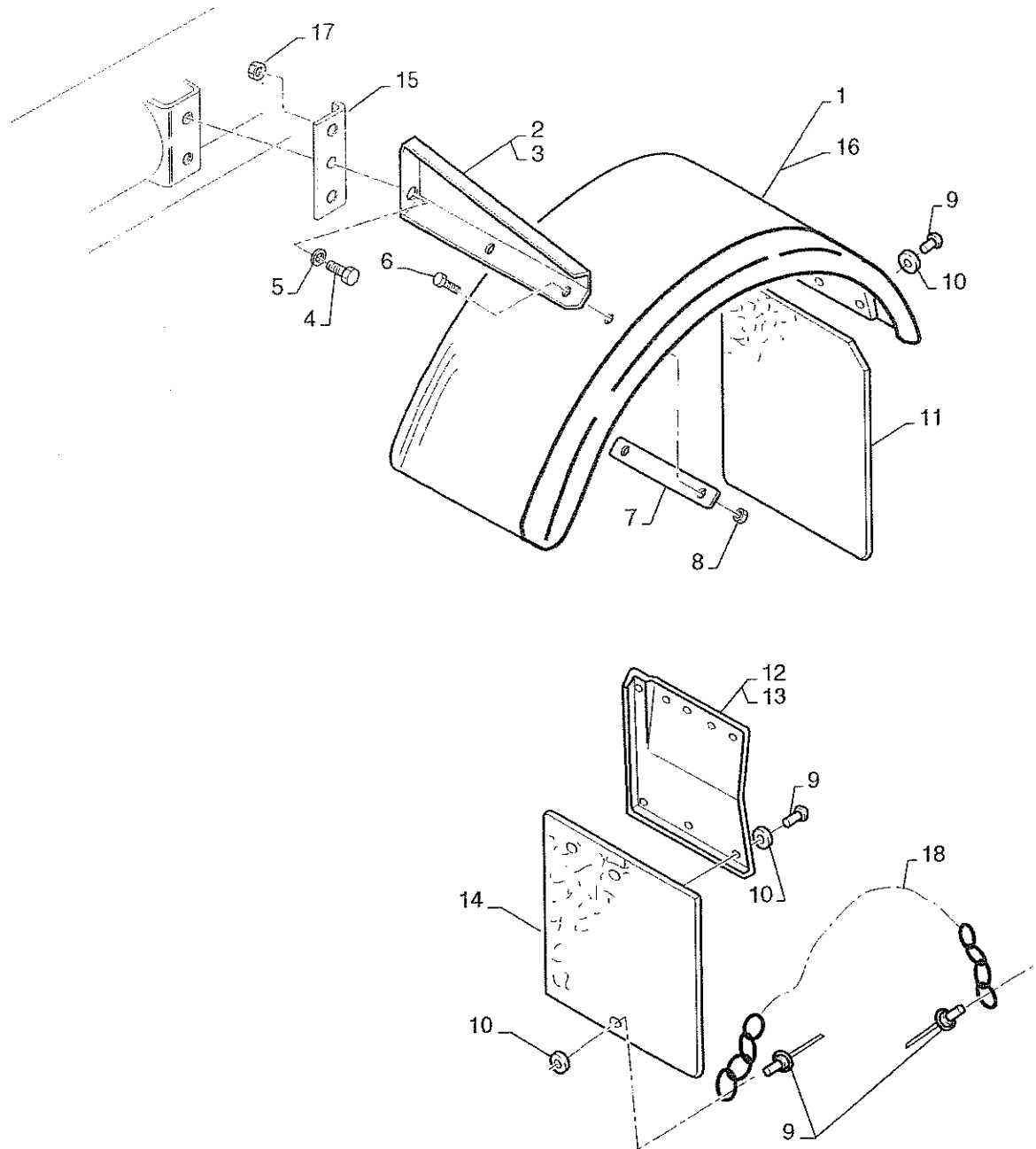

<input type="checkbox"/> 35 <input type="checkbox"/> 45	TUR E3 <input type="checkbox"/>	20 <input type="checkbox"/>	4X4 <input type="checkbox"/>	<input type="checkbox"/> <input type="checkbox"/>	<input type="checkbox"/> <input type="checkbox"/>	CEE <input type="checkbox"/>	<input type="checkbox"/> <input type="checkbox"/>	<input type="checkbox"/> <input type="checkbox"/>	<input type="checkbox"/> YES <input type="checkbox"/> NO
------------------------------------------------------------	------------------------------------	-----------------------------	------------------------------	---------------------------------------------------	---------------------------------------------------	------------------------------	---------------------------------------------------	---------------------------------------------------	-------------------------------------------------------------

BREMACHParafanghi e paraspruzzi
Wings and mudguard flapsTAV. **80.7**
EXTREME Ed. 04 / 2002

N. Pos.	COD.	DENOMINAZIONE	Q.ty	DESCRIPTION	Da matricola Serial number
1	90N1506D	Parafango posteriore destro	1	Right splash-board	200001
2	90S9125D	Staffa destra	2	Bracket	200001
3	90S9125S	Staffa sinistra	2	Bracket	200001
4	201021	Vite M 8x20 UNI 5739-65	12	Bolt	200001
5	203003	Rondella elastica 8x16x1,9	12	Washer	200001
6	201012	Vite M 6x20 UNI 5739	8	Bolt	200001
7	90N1502	Piattina lato interno parafango per mont. rivetti	4	Internal plate	200001
8	202101	Dado M 6 autobloccante	32	Self-locking nut	200001
9	E4169	Rivetto 4,9x16	16	Rivet	200001
10	203102	Rondella piana 5x16x1,6 UNI 6593-69 ring	14	Washer	200001
11	83620	Paraspruzzi 23x27	2	Splash guard	200001
12	E4097	Lamiera paraspruzzi destra	1	Right mud guard plate	200001
13	E4098	Lamiera paraspruzzi sinistra	1	Left mud guard plate	200001
14	E4070	Paraspruzzi 45x30 per ruota anteriore	1	Splash guard	200001
15	90N1508	Supporto per staffa	2	Support	200001
16	90N1506S	Parafango posteriore sinistro	1	Left splash-board	200001
17	202004	Dado M8	4	Nut	200001
18	90N1507	Catenella	2	Chain	200001

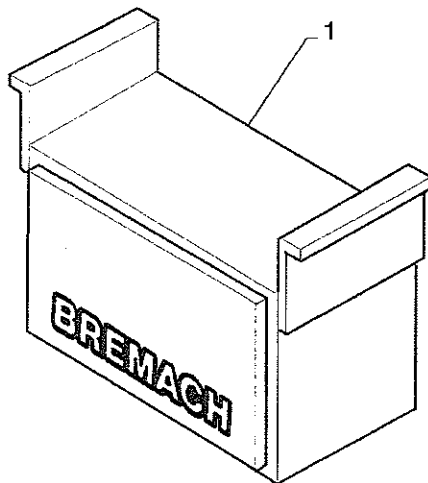

BREMACHCassetta porta attrezzi
Tools boxTAV. **80.8**

EXTREME Ed. 04 / 2002

N. Pos.	COD.	DENOMINAZIONE	Q.ty	DESCRIPTION	Da matricola Serial number
1	90T6001	Cassetta porta attrezzi	1	Case	200001

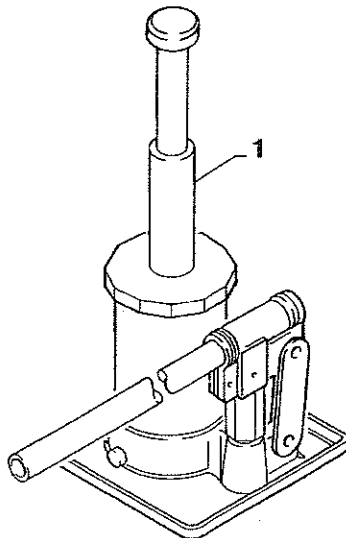
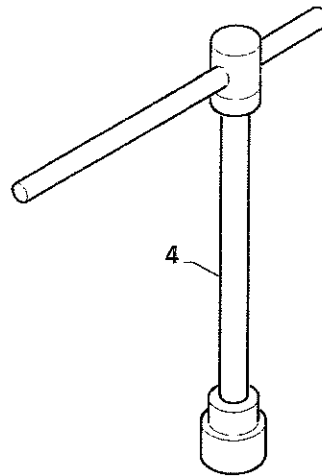
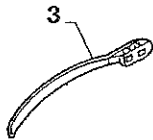
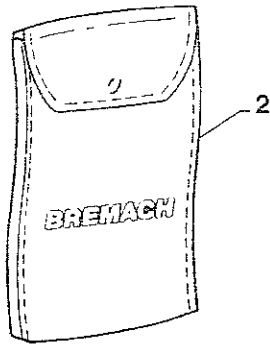

BREMACH

Attrezzi e accessori

Tools and fittings

TAV.

80.9

EXTREME Ed. 04 / 2002

N. Pos.	COD.	DENOMINAZIONE	Q.ty	DESCRIPTION	Da matricola Serial number
1	81386	Martinetto con leva	1	Jack	200001
2	90T5005	Kit attrezzi	1	Tool kit	200001
3	81674	Cinghietta per martinetto	1	Belt	200001
4	90T5000	Chiave a tubo	1	Key	200001

EXTREME

**Gruppo
Group**

90

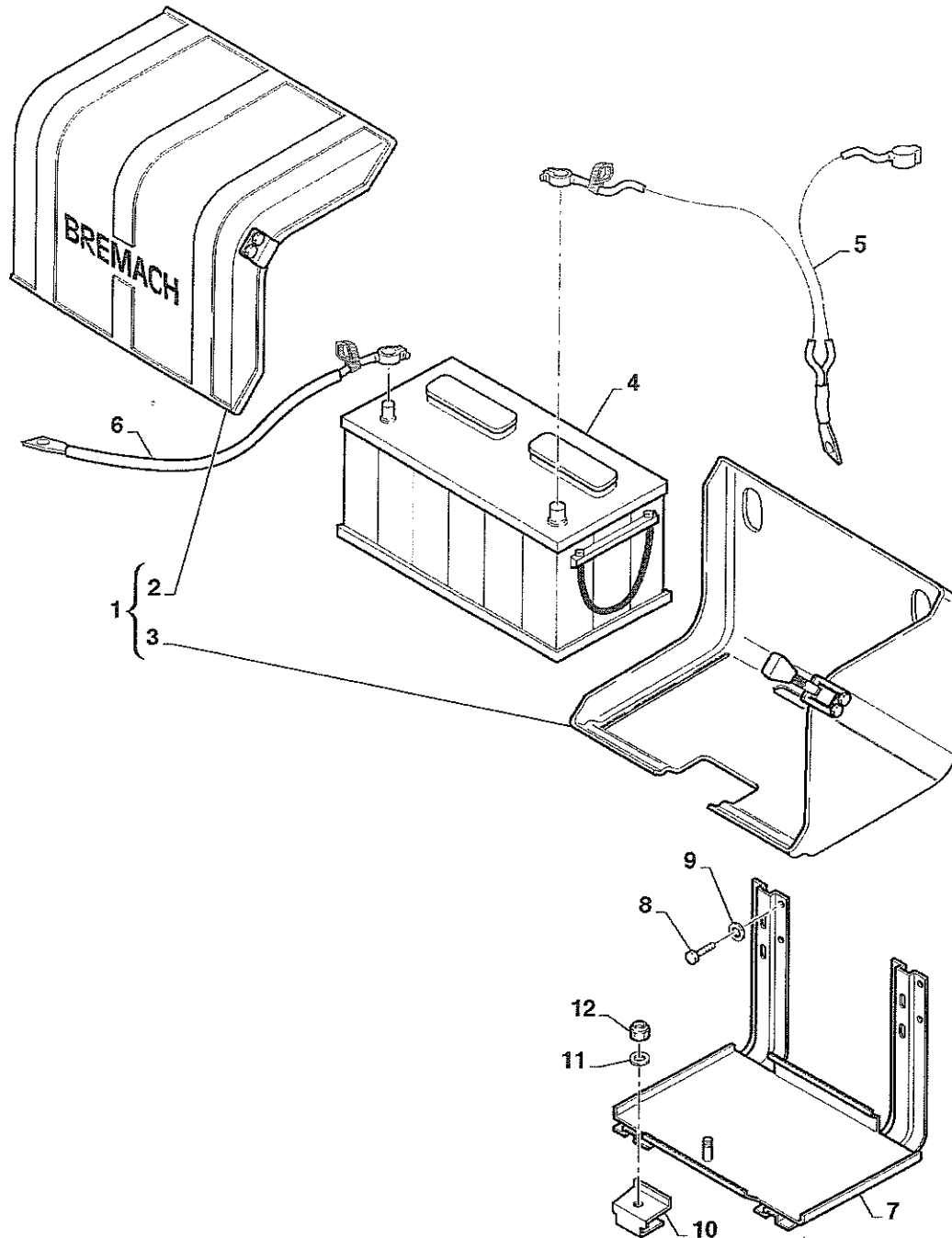

N. Pos.	COD.	DENOMINAZIONE	Q.ty	DESCRIPTION	Da matricola Serial number
1	010Q55	Riparo batteria completo	1	Complete protection	200001
2	90N9404	. Semiscatola superiore	1	Housing	200001
3	90N9403	. Semiscatola inferiore	1	Housing	200001
4	81400	Batteria	1	Battery	200001
5	I5007	Cavo polo positivo batteria	1	Cable	200001
6	I5008	Cavo polo negativo batteria (massa)	1	Cable	200001
7	A1013	Supporto batteria completo	1	Support	200001
8	201020	Vite M 8x16	8	Bolt	200001
9	203003	Rondella	8	Washer	200001
10	A1014	Piastra fissaggio batteria	1	Plate	200001
11	203002	Rondella elastica	1	Washer	200001
12	202101	Dado autobloccante M6	1	Self-locking nut	200001

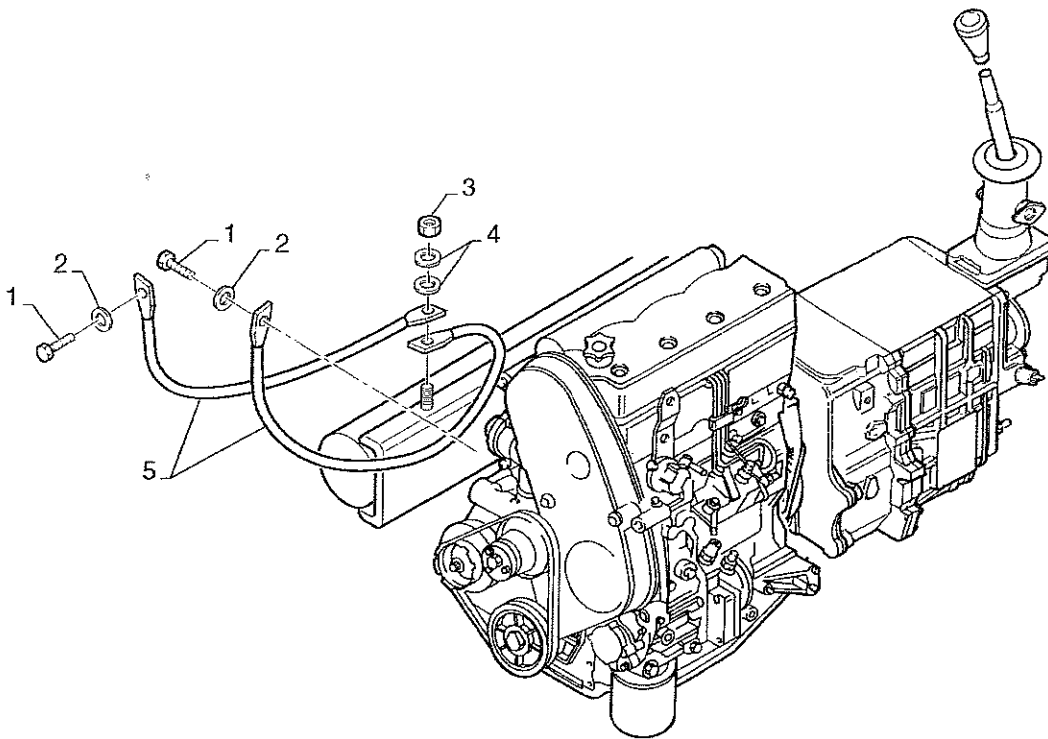

<input type="checkbox"/> 35 <input type="checkbox"/> 45	TUR <input type="checkbox"/> E9	<input type="checkbox"/> 20	<input type="checkbox"/> 4x4	<input type="checkbox"/> <input type="checkbox"/>	<input type="checkbox"/> <input type="checkbox"/>	CEE <input type="checkbox"/>	<input type="checkbox"/> <input type="checkbox"/>	<input type="checkbox"/> <input type="checkbox"/>	<input type="checkbox"/> YES <input type="checkbox"/> NO
------------------------------------------------------------	------------------------------------	-----------------------------	------------------------------	---------------------------------------------------	---------------------------------------------------	---------------------------------	---------------------------------------------------	---------------------------------------------------	-------------------------------------------------------------

BREMACHTreccia messa a massa motore
Engine earth connection cableTAV. **90.2**

EXTREME Ed. 04 / 2002

N. Pos.	COD.	DENOMINAZIONE	Q.ty	DESCRIPTION	Da matricola Serial number
1	201089	Vite	2	Bolt	200001
2	203005	Rondella	2	Washer	200001
3	202004	Dado	1	Nut	200001
4	203110	Rondella	2	Washer	200001
5	90I1011	Treccia messa a massa motore	2	Cable	200001

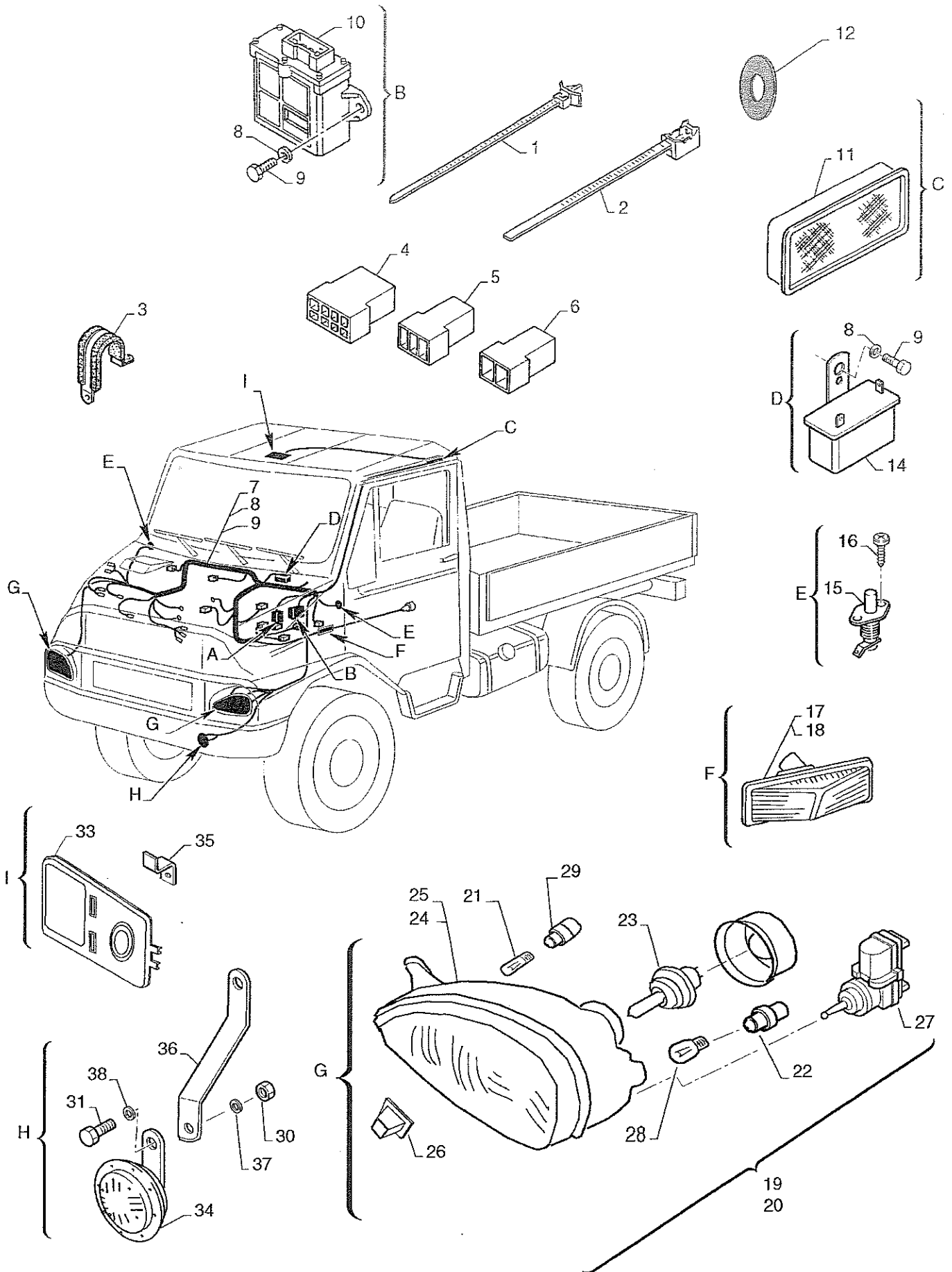

<input type="checkbox"/> 35	TUR <input type="checkbox"/> E3 <input type="checkbox"/>	<input type="checkbox"/> 20	<input type="checkbox"/> 4x4	<input type="checkbox"/>	<input type="checkbox"/>	<input type="checkbox"/>	CEE <input type="checkbox"/>	<input type="checkbox"/>	<input type="checkbox"/>	<input type="checkbox"/>	<input type="checkbox"/> YES <input type="checkbox"/> NO
-----------------------------	-------------------------------------------------------------	-----------------------------	------------------------------	--------------------------	--------------------------	--------------------------	------------------------------	--------------------------	--------------------------	--------------------------	-------------------------------------------------------------

N. Pos.	COD.	DENOMINAZIONE	Q.ty	DESCRIPTION	Da matricola Serial number
1	I1004	Fascetta	-	Clamp	200001
2	I1003	Fascetta	-	Clamp	200001
3	I5014	Cavaliotto	-	U-bolt	200001
4	I5011	Connettore	-	Connector	200001
5	I5009	Connettore	-	Connector	200001
6	I5010	Connettore	-	Connector	200001
7	91I1007	Cablaggio anteriore cabina (E3)	1	Wiring	200001
8	91I1006	Cablaggio sottocruscotto (E3)	1	Wiring	200001
9	90I1008	Cablaggio Common Rai (E3)	1	Wiring	200001
10	90P1007	Adattatore segnale elettrico per contachilometri	1	Adapter	200001
11	F2000	Plafoniera completa	-	Roof lamp	200001
12	92P6017	Gommino	1	Rubber	200001
13	K2113	Prolunga cablaggio per 2° plaf. per furgonati e promiscui	1	Extension	200001
14	A9540	Centralina indicatore blocco differenziale	1	Box	200001
15	E4174	Interruttore porta	2	Switch	200001
16	204005	Vite autofilettante	4	Bolt	200001
17	E5001	Freccia laterale destra	1	Direction indicator	200001
18	E5002	Freccia laterale sinistra	1	Direction indicator	200001
19		Faro completo destro	1	Complete right light set	200001
20		Faro completo sinistro	1	Complete left light set	200001
21	90I1076	. Lampada luci citt1 12V-5W	1	. Lamp	200001
22	90I1105	.Porta lampada luci di direzione	1	. Lamp holder	200001
23	90I1077	. Lampada alogena H4 12V - 55/60W	1	. Lamp	200001
24	90I1073	. Gruppo ottico anteriore destro	1	. Left front med light assy	200001
25	90I1074	. Gruppo ottico anteriore sinistro	1	. Right front med light assy	200001
26	90I1079	. Tassello di supporto fanale anteriore	2	. Support	200001
27	90I1078	. Motorino fari	1	. Motor	200001
28	83011	. Lampadina 21W	2	. Lamp	200001
29	90I1104	. Porta lampada luci di posizione	2	. Lamp holder	200001
30	202004	Dado M8	1	Nut	200001
31	201021	Vite TE M8x20	1	Bolt	200001
33	90P1637	Plafoniera con proiettore	1	Spotlight roof lamp	200001
34	81411	Avvisatore acustico	1	Horn	200001
35	90E1083	Staffa di sostegno plafoniera centrale	1	Bracket	200001
36	2814.002	Staffa supporto tromba	1	Bracket	200001
37	203003	Rondella	1	Washer	200001
38	203110	Rondella	1	Washer	200001

Codici in bianco : da richiedere al magazzino ricambi prima di inviare l'ordine.

N. Pos.	COD.	DENOMINAZIONE	Q.ty	DESCRIPTION	Da matricola Serial number
1	I1004	Fascetta	-	Clamp	200001
2	I1003	Fascetta	-	Clamp	200001
3	I5014	Cavallotto	-	U-bolt	200001
4	I5011	Connettore	-	Connector	200001
5	I5009	Connettore	-	Connector	200001
6	I5010	Connettore	-	Connector	200001
7	F1000	Luce targa	2	Number plate light	200001
8	201011	Vite M 5x16 UNI 5739-65	4	Bolt	200001
9	203102	Rondella piana 5x15x1,6 UNI 6593-69	5	Washer	200001
10	202002	Dado M 5 UNI 5587-68	4	Nut	200001
11	90I1122	Fanale posteriore rotondo con luci direzionali	2	Signal light	200001
12	90I0102	Trasparente posteriore (luci direzionali)	1		200001
13	90I0104	Trasparente posteriore (luci retronebbia)	1		200001
14	90I0103	Trasparente posteriore (luci retromarcia)	1		200001
15	83011	Lampadina 21W	6	Lamp	200001
16	83013	Lampadina 3W	2	Lamp	200001
17	203002	Rondella elastica 6x18x1,6	2	Washer	200001
18	202003	Dado M 6 UNI 5587-68	2	Nut	200001
19	90I1124	Fanale retronebbia rotondo completo	1	Signal light	200001
20	90I1123	Fanale retromarcia rotondo completo	1	Signal light	200001
21	90I1033	Staccabatteria completo	1	Breaker	200001
22	202101	Dado	2	Nut	200001
23	203002	Rondella	4	Washer	200001
24	201014	Vite TE	4	Bolt	200001
25	91I1010	Cablaggio posteriore	1	Wiring	200001
26	91I1009	Cablaggio centrale	1	Wiring	200001
27	90I1125	Catadiotro	2	Reflecting	200001
28	90N2027	Staffa sostegno catadiotro	2	Bracket	200001

Indice alfanumerico Alphanumeric index

Catalogo ricambi EXTREME
motore EURO 3
Edizione aprile 2002
pagine n.8

COD.	TAV.	POS.	EDIZ.	COD.	TAV.	POS.	EDIZ.	COD.	TAV.	POS.	EDIZ.
010Q55	90,1	1	04/2002	201026	0,21	7	04/2002	201201	60,32	9	04/2002
201001	10,441	15	04/2002	201026	20,12	11	04/2002	201210	10,311	15	04/2002
201001	10,442	15	04/2002	201026	20,221	4	04/2002	201210	10,312	15	04/2002
201001	60,7	18	04/2002	201027	10,24	34	04/2002	201211	60,12	31	04/2002
201001	80,314	15	04/2002	201027	40,11	4	04/2002	201213	60,131	19	04/2002
201002	60,41	32	04/2002	201027	60,511	6	04/2002	201213	60,132	7	04/2002
201002	60,42	9	04/2002	201027	60,512	7	04/2002	201213	60,141	15	04/2002
201010	60,131	5	04/2002	201027	80,121	2	04/2002	201214	60,131	37	04/2002
201010	60,141	4	04/2002	201027	80,21	2	04/2002	201222	70,1	25	04/2002
201011	50,11	2	04/2002	201028	80,31	27	04/2002	201301	60,131	38	04/2002
201011	50,22	10	04/2002	201028	80,32	24	04/2002	201301	60,32	22	04/2002
201011	60,11	17	04/2002	201030	10,43	8	04/2002	201302	60,131	2	04/2002
201011	60,12	17	04/2002	201030	80,314	32	04/2002	201303	60,31	7	04/2002
201011	60,131	6	04/2002	201031	0,22	3	04/2002	201303	60,32	13	04/2002
201011	60,141	5	04/2002	201031	0,32	2	04/2002	201305	60,132	6	04/2002
201011	60,62	6	04/2002	201031	40,12	21	04/2002	201306	60,41	2	04/2002
201011	90,4	6	04/2002	201031	80,313	16	04/2002	201401	0,42	14	04/2002
201012	0,42	23	04/2002	201032	20,12	10	04/2002	201402	80,4	5	04/2002
201012	50,11	6	04/2002	201032	20,221	5	04/2002	201421	60,131	35	04/2002
201012	50,22	12	04/2002	201034	80,31	9	04/2002	201421	60,141	24	04/2002
201012	60,11	19	04/2002	201038	80,23	1	04/2002	201501	60,41	39	04/2002
201012	60,12	19	04/2002	201039	10,322	44	04/2002	201503	60,42	10	04/2002
201012	60,43	18	04/2002	201039	10,323	44	04/2002	201509	60,41	30	04/2002
201012	60,52	11	04/2002	201039	40,13	1	04/2002	201510	60,151	22	04/2002
201012	80,131	24	04/2002	201040	30,122	6	04/2002	201510	60,152	22	04/2002
201012	80,313	18	04/2002	201040	30,22	6	04/2002	201601	10,27	10	04/2002
201012	80,7	6	04/2002	201040	60,32	21	04/2002	201601	10,27	5	04/2002
201013	50,11	20	04/2002	201041	0,22	7	04/2002	201601	40,21	10	04/2002
201013	60,11	18	04/2002	201041	0,521	6	04/2002	201601	80,22	5	04/2002
201013	60,12	18	04/2002	201041	10,283	3	04/2002	201606	80,31	2	04/2002
201014	60,11	16	04/2002	201041	10,441	27	04/2002	201606	80,6	17	04/2002
201014	60,12	16	04/2002	201041	10,442	27	04/2002	202002	40,21	13	04/2002
201014	90,4	24	04/2002	201041	60,151	2	04/2002	202002	70,1	6	04/2002
201015	40,21	15	04/2002	201041	60,152	2	04/2002	202002	80,314	17	04/2002
201020	0,42	2	04/2002	201041	80,14	3	04/2002	202002	80,314	21	04/2002
201020	0,521	13	04/2002	201041	80,31	15	04/2002	202002	90,4	10	04/2002
201020	0,61	2	04/2002	201041	80,314	24	04/2002	202003	0,13	26	04/2002
201020	10,283	10	04/2002	201041	80,314	26	04/2002	202003	0,42	22	04/2002
201020	10,322	47	04/2002	201041	80,6	8	04/2002	202003	0,51	5	04/2002
201020	10,323	48	04/2002	201042	10,322	14	04/2002	202003	0,521	18	04/2002
201020	30,21	11	04/2002	201042	10,323	14	04/2002	202003	10,27	11	04/2002
201020	60,11	20	04/2002	201042	30,122	17	04/2002	202003	10,27	18	04/2002
201020	60,12	20	04/2002	201042	30,22	17	04/2002	202003	10,27	6	04/2002
201020	80,313	29	04/2002	201042	80,31	17	04/2002	202003	40,21	11	04/2002
201020	80,5	1	04/2002	201042	80,32	1	04/2002	202003	50,11	22	04/2002
201020	80,6	13	04/2002	201045	80,131	11	04/2002	202003	50,11	4	04/2002
201020	90,1	8	04/2002	201045	80,14	4	04/2002	202003	50,22	13	04/2002
201021	0,32	13	04/2002	201047	10,283	7	04/2002	202003	60,11	23	04/2002
201021	0,61	25	04/2002	201051	80,314	3	04/2002	202003	60,12	23	04/2002
201021	10,27	17	04/2002	201054	80,14	2	04/2002	202003	60,131	7	04/2002
201021	10,421	2	04/2002	201060	10,283	4	04/2002	202003	60,141	3	04/2002
201021	10,441	17	04/2002	201060	30,11	20	04/2002	202003	60,151	11	04/2002
201021	10,442	17	04/2002	201060	30,21	21	04/2002	202003	60,152	11	04/2002
201021	60,12	30	04/2002	201061	30,122	11	04/2002	202003	60,43	17	04/2002
201021	60,43	13	04/2002	201061	30,22	11	04/2002	202003	60,52	9	04/2002
201021	60,511	9	04/2002	201062	50,21	10	04/2002	202003	70,1	21	04/2002
201021	60,512	10	04/2002	201064	80,4	2	04/2002	202003	70,1	7	04/2002
201021	80,14	1	04/2002	201075	10,12	2	04/2002	202003	80,22	4	04/2002
201021	80,22	21	04/2002	201075	10,13	2	04/2002	202003	90,4	18	04/2002
201021	80,6	16	04/2002	201080	10,412	13	04/2002	202004	0,32	4	04/2002
201021	80,7	4	04/2002	201080	10,421	17	04/2002	202004	0,42	7	04/2002
201021	90,3	31	04/2002	201080	10,422	13	04/2002	202004	0,521	10	04/2002
201022	0,42	5	04/2002	201081	0,13	21	04/2002	202004	0,521	4	04/2002
201022	10,24	30	04/2002	201082	0,21	9	04/2002	202004	0,61	11	04/2002
201022	30,11	5	04/2002	201083	10,322	45	04/2002	202004	10,25	12	04/2002
201022	30,21	14	04/2002	201083	10,323	45	04/2002	202004	10,26	15	04/2002
201022	40,11	3	04/2002	201089	90,2	1	04/2002	202004	10,27	19	04/2002
201022	60,43	10	04/2002	201093	50,21	8	04/2002	202004	10,322	49	04/2002
201022	60,7	9	04/2002	201094	50,21	7	04/2002	202004	10,323	50	04/2002
201022	80,121	1	04/2002	201095	50,21	5	04/2002	202004	10,412	14	04/2002
201022	80,21	1	04/2002	201102	0,42	19	04/2002	202004	10,421	18	04/2002
201023	0,61	21	04/2002	201107	70,1	14	04/2002	202004	10,422	14	04/2002
201023	10,21	8	04/2002	201109	60,43	33	04/2002	202004	10,441	26	04/2002
201023	10,22	18	04/2002	201109	80,131	19	04/2002	202004	10,442	26	04/2002
201023	10,23	8	04/2002	201122	80,23	2	04/2002	202004	30,21	10	04/2002
201023	10,24	32	04/2002	201124	10,22	20	04/2002	202004	40,11	5	04/2002
201023	20,12	9	04/2002	201133	80,6	19	04/2002	202004	40,12	5	04/2002
201023	20,221	2	04/2002	201141	80,31	31	04/2002	202004	40,21	20	04/2002
201023	40,12	3	04/2002	201141	80,32	30	04/2002	202004	60,43	12	04/2002
201023	60,511	11	04/2002	201152	0,32	11	04/2002	202004	60,511	8	04/2002
201023	60,512	12	04/2002	201154	80,313	8	04/2002	202004	60,512	9	04/2002
201024	0,21	5	04/2002	201156	80,121	3	04/2002	202004	60,7	13	04/2002
201024	10,22	21	04/2002	201160	60,151	5	04/2002	202004	80,11	14	04/2002
201024	20,12	14	04/2002	201160	60,152	5	04/2002	202004	80,14	5	04/2002
201024	20,221	3	04/2002	2011612	50,12	4	04/2002	202004	80,31	10	04/2002
201024	20,12	22	04/2002	201201	60,31	3	04/2002	202004	80,313	31	04/2002



COD.	TAV.	POS.	EDIZ.	COD.	TAV.	POS.	EDIZ.	COD.	TAV.	POS.	EDIZ.
202004	80,7	17	04/2002	202107	60,151	15	04 / 2002	203004	0,13	33	04 / 2002
202004	90,2	3	04 / 2002	202107	60,152	15	04 / 2002	203004	0,21	10	04 / 2002
202004	90,3	30	04 / 2002	202109	80,131	13	04 / 2002	203004	0,22	9	04 / 2002
202005	0,521	8	04 / 2002	202109	80,4	4	04 / 2002	203004	0,521	28	04 / 2002
202005	30,122	7	04 / 2002	202110	20,221	16	04 / 2002	203004	10,283	2	04 / 2002
202005	30,22	7	04 / 2002	202113	50,21	9	04 / 2002	203004	10,283	8	04 / 2002
202005	40,12	12	04 / 2002	202114	20,12	17	04 / 2002	203004	10,322	15	04 / 2002
202005	40,21	29	04 / 2002	202202	0,13	24	04 / 2002	203004	10,323	15	04 / 2002
202005	80,6	10	04 / 2002	202202	0,21	12	04 / 2002	203004	10,412	15	04 / 2002
202006	10,26	23	04 / 2002	202202	10,441	23	04 / 2002	203004	10,421	19	04 / 2002
202006	60,151	7	04 / 2002	202202	10,442	23	04 / 2002	203004	10,422	15	04 / 2002
202006	60,152	7	04 / 2002	202203	50,13	4	04 / 2002	203004	10,441	28	04/2002
202006	80,314	5	04 / 2002	202204	50,13	5	04 / 2002	203004	10,442	28	04/2002
202007	10,25	20	04 / 2002	202304	0,21	11	04 / 2002	203004	30,122	8	04 / 2002
202008	10,283	5	04 / 2002	203001	50,11	21	04 / 2002	203004	30,22	8	04 / 2002
202008	30,11	22	04 / 2002	203001	60,131	4	04 / 2002	203004	40,12	11	04 / 2002
202008	30,122	13	04 / 2002	203001	60,141	2	04 / 2002	203004	40,13	3	04 / 2002
202008	30,21	23	04 / 2002	203001	60,151	10	04 / 2002	203004	50,22	19	04 / 2002
202008	30,22	13	04 / 2002	203001	60,152	10	04 / 2002	203004	60,151	3	04 / 2002
202010	70,1	10	04 / 2002	203001	80,313	17	04 / 2002	203004	60,152	3	04 / 2002
202012	0,22	6	04 / 2002	203002	0,42	20	04/2002	203004	80,131	7	04 / 2002
202012	10,25	10	04 / 2002	203002	0,51	4	04 / 2002	203004	80,14	9	04 / 2002
202012	10,26	13	04 / 2002	203002	40,12	18	04 / 2002	203004	80,23	4	04 / 2002
202012	10,27	23	04 / 2002	203002	50,11	3	04 / 2002	203004	80,31	32	04 / 2002
202012	40,12	28	04 / 2002	203002	50,22	11	04 / 2002	203004	80,32	3	04 / 2002
202012	40,21	25	04 / 2002	203002	60,11	21	04 / 2002	203004	80,6	9	04 / 2002
202012	80,11	6	04 / 2002	203002	60,12	21	04 / 2002	203005	30,11	17	04 / 2002
202012	80,22	12	04 / 2002	203002	60,151	16	04 / 2002	203005	30,11	4	04 / 2002
202012	80,31	30	04 / 2002	203002	60,152	16	04 / 2002	203005	30,21	7	04 / 2002
202012	80,32	26	04/2002	203002	60,43	26	04 / 2002	203005	40,111	3	04 / 2002
202018	0,22	8	04 / 2002	203002	60,52	10	04 / 2002	203005	50,21	11	04 / 2002
202021	60,43	14	04 / 2002	203002	60,62	7	04 / 2002	203005	60,151	6	04 / 2002
202024	0,21	6	04 / 2002	203002	70,1	8	04 / 2002	203005	60,152	6	04 / 2002
202101	40,12	16	04 / 2002	203002	80,131	23	04 / 2002	203005	80,22	8	04 / 2002
202101	40,21	16	04 / 2002	203002	90,1	11	04 / 2002	203005	80,314	4	04 / 2002
202101	60,11	24	04 / 2002	203002	90,4	17	04 / 2002	203005	90,2	2	04 / 2002
202101	60,12	24	04 / 2002	203002	90,4	23	04 / 2002	203101	80,314	16	04 / 2002
202101	60,43	31	04/2002	203003	0,21	4	04 / 2002	203102	60,41	24	04 / 2002
202101	60,52	12	04 / 2002	203003	0,22	4	04 / 2002	203102	60,7	21	04 / 2002
202101	70,1	26	04/2002	203003	0,32	14	04 / 2002	203102	70,1	5	04 / 2002
202101	80,7	8	04 / 2002	203003	0,32	3	04 / 2002	203102	80,7	10	04 / 2002
202101	90,1	12	04 / 2002	203003	0,42	3	04 / 2002	203102	90,4	9	04 / 2002
202101	90,4	22	04 / 2002	203003	0,42	6	04 / 2002	203103	10,43	9	04 / 2002
202102	10,21	10	04 / 2002	203003	0,521	3	04 / 2002	203103	80,14	10	04 / 2002
202102	10,23	10	04 / 2002	203003	0,521	9	04 / 2002	203103	80,31	8	04 / 2002
202102	10,24	33	04 / 2002	203003	0,61	10	04 / 2002	203104	60,7	11	04 / 2002
202102	10,441	12	04 / 2002	203003	0,61	3	04 / 2002	203105	0,521	7	04 / 2002
202102	10,442	12	04 / 2002	203003	10,21	9	04 / 2002	203109	30,11	1	04 / 2002
202102	30,11	2	04 / 2002	203003	10,22	19	04 / 2002	203109	30,21	24	04 / 2002
202102	40,12	19	04 / 2002	203003	10,23	9	04 / 2002	203110	0,61	20	04 / 2002
202102	60,43	32	04/2002	203003	10,24	31	04 / 2002	203110	10,441	16	04 / 2002
202102	60,511	10	04 / 2002	203003	10,25	11	04 / 2002	203110	10,442	16	04 / 2002
202102	60,512	11	04 / 2002	203003	10,26	14	04 / 2002	203110	60,511	7	04 / 2002
202102	80,121	4	04 / 2002	203003	10,283	11	04 / 2002	203110	60,512	8	04 / 2002
202102	80,14	6	04 / 2002	203003	10,322	48	04 / 2002	203110	60,7	10	04 / 2002
202102	80,21	3	04 / 2002	203003	10,323	49	04 / 2002	203110	80,313	13	04 / 2002
202102	80,313	12	04 / 2002	203003	10,412	23	04 / 2002	203110	90,2	4	04 / 2002
202102	80,314	22	04 / 2002	203003	10,421	23	04 / 2002	203110	90,3	38	04 / 2002
202102	80,314	28	04 / 2002	203003	10,422	23	04 / 2002	203114	0,13	25	04 / 2002
202102	80,6	18	04 / 2002	203003	10,441	11	04 / 2002	203115	70,1	22	04 / 2002
202103	10,25	5	04 / 2002	203003	10,442	11	04 / 2002	203201	30,11	21	04 / 2002
202103	10,441	29	04/2002	203003	20,12	12	04 / 2002	203201	30,122	12	04 / 2002
202103	10,442	29	04/2002	203003	20,221	6	04 / 2002	203201	30,21	22	04 / 2002
202103	30,122	14	04 / 2002	203003	30,21	9	04 / 2002	203201	30,22	12	04 / 2002
202103	30,22	14	04 / 2002	203003	40,11	2	04 / 2002	203201	40,11	15	04 / 2002
202103	40,13	2	04 / 2002	203003	40,12	4	04 / 2002	203210	50,21	6	04 / 2002
202103	40,21	27	04 / 2002	203003	40,21	19	04 / 2002	203210	80,131	14	04 / 2002
202103	50,12	3	04 / 2002	203003	60,11	22	04 / 2002	203300	60,11	30	04 / 2002
202103	60,151	4	04 / 2002	203003	60,12	22	04 / 2002	203300	60,12	36	04 / 2002
202103	60,152	4	04 / 2002	203003	60,43	11	04 / 2002	203300	60,31	6	04 / 2002
202103	60,43	9	04 / 2002	203003	60,7	12	04 / 2002	203300	60,32	12	04 / 2002
202103	80,11	8	04 / 2002	203003	80,11	7	04 / 2002	203300	60,32	20	04 / 2002
202103	80,14	7	04 / 2002	203003	80,121	5	04 / 2002	203300	60,41	34	04 / 2002
202103	80,23	3	04 / 2002	203003	80,131	20	04 / 2002	204001	10,25	17	04 / 2002
202103	80,31	16	04 / 2002	203003	80,14	8	04 / 2002	204001	10,26	18	04 / 2002
202103	80,31	33	04 / 2002	203003	80,21	4	04 / 2002	204001	10,27	28	04 / 2002
202103	80,314	27	04 / 2002	203003	80,22	13	04 / 2002	204001	60,41	23	04 / 2002
202103	80,32	2	04 / 2002	203003	80,31	28	04 / 2002	204002	60,41	19	04 / 2002
202104	10,12	3	04 / 2002	203003	80,313	30	04 / 2002	204003	0,42	12	04 / 2002
202104	10,13	3	04 / 2002	203003	80,314	34	04 / 2002	204003	60,131	14	04 / 2002
202104	10,27	13	04 / 2002	203003	80,32	25	04/2002	204005	60,141	32	04 / 2002
202104	30,11	18	04 / 2002	203003	80,5	2	04 / 2002	204005	60,32	5	04 / 2002
202104	30,21	8	04 / 2002	203003	80,6	14	04 / 2002	204005	90,3	16	04 / 2002
202104	50,21	12	04 / 2002	203003	80,7	5	04 / 2002	204010	60,11	31	04 / 2002
202104	80,22	9	04 / 2002	203003	90,1	9	04 / 2002	204010	60,12	37	04 / 2002
202104	80,31	11	04 / 2002	203003	90,3	37	04 / 2002	204010	60,32	6	04 / 2002

COD.	TAV.	POS.	EDIZ.	COD.	TAV.	POS.	EDIZ.	COD.	TAV.	POS.	EDIZ.
204010	60,41	33	04 / 2002	81053	10,311	12	04 / 2002	83858	10,27	29	04 / 2002
204011	60,41	26	04 / 2002	81053	10,312	12	04 / 2002	83984	60,12	32	04 / 2002
204012	0,521	19	04 / 2002	81053	10,322	21	04 / 2002	83984	60,132	3	04 / 2002
204014	60,41	38	04/2002	81053	10,323	21	04 / 2002	83984	60,141	19	04 / 2002
205001	40,21	30	04 / 2002	81110	50,11	9	04 / 2002	83984	60,31	11	04 / 2002
205001	60,141	30	04 / 2002	81322	80,31	14	04 / 2002	83984	60,32	18	04 / 2002
205001	60,43	21	04 / 2002	81386	80,9	1	04 / 2002	83984	80,6	6	04 / 2002
205001	60,43	6	04 / 2002	81400	90,1	4	04 / 2002	84053	80,313	28	04 / 2002
205003	10,412	16	04 / 2002	81411	90,3	34	04 / 2002	84056	80,313	27	04 / 2002
205003	10,421	20	04 / 2002	81535	40,21	31	04 / 2002	89544	80,31	24	04 / 2002
205003	10,422	16	04 / 2002	81535	60,141	29	04 / 2002	90A0920	10,412	24	04 / 2002
207003	80,314	38	04 / 2002	81535	60,43	20	04 / 2002	90A1001	30,11	3	04 / 2002
207004	80,314	37	04 / 2002	81674	80,9	3	04 / 2002	90A1001	30,21	13	04 / 2002
211002	80,131	8	04 / 2002	81863	80,31	18	04 / 2002	90A1005	30,21	6	04 / 2002
211003	80,131	18	04 / 2002	82269	40,11	7	04 / 2002	90A1007	30,11	9	04 / 2002
211006	80,131	15	04 / 2002	82274	40,11	14	04 / 2002	90A1007	30,21	19	04 / 2002
213106	80,4	3	04 / 2002	82278	40,11	1	04 / 2002	90A1009	30,11	13	04 / 2002
2814.002	90,3	36	04 / 2002	82278	40,12	2	04 / 2002	90A1011	30,21	3	04 / 2002
28440	60,11	2	04 / 2002	82313	60,22	6	04 / 2002	90A1025D	30,11	15	04 / 2002
2853.006	60,42	25	04 / 2002	83011	90,3	28	04 / 2002	90A1025D	30,21	4	04 / 2002
28771	60,12	2	04 / 2002	83011	90,4	15	04 / 2002	90A1025S	30,11	16	04 / 2002
60201	40,12	29	04 / 2002	83013	90,4	16	04 / 2002	90A1025S	30,21	5	04 / 2002
80473	20,12	18	04 / 2002	83023	50,11	17	04 / 2002	90A1028	30,11	26	04/2002
80473	20,221	17	04 / 2002	83075	10,24	23	04 / 2002	90A1028	30,21	27	04/2002
80489	0,13	5	04/2002	83075	80,21	6	04 / 2002	90A1029	30,11	29	04/2002
80490	0,13	35	04/2002	83138	0,51	9	04 / 2002	90A1029	30,21	30	04/2002
80677	10,21	1	04 / 2002	83138	40,11	26	04 / 2002	90A1030	30,11	27	04/2002
80677	10,23	2	04 / 2002	83235	60,21	4	04 / 2002	90A1030	30,21	28	04/2002
80677	10,24	19	04 / 2002	83235	60,22	1	04 / 2002	90A1032	30,11	28	04/2002
80677	10,25	14	04 / 2002	83236	60,21	5	04 / 2002	90A1032	30,21	29	04/2002
80677	10,26	21	04 / 2002	83236	60,22	2	04 / 2002	90A1034	30,21	20	04 / 2002
80677	10,27	25	04 / 2002	83371	60,43	5	04 / 2002	90A2003	10,441	6	04 / 2002
80677	80,121	6	04 / 2002	83372	10,25	9	04 / 2002	90A2003	10,442	6	04 / 2002
80677	80,21	5	04 / 2002	83372	10,26	12	04 / 2002	90A2004	10,412	3	04 / 2002
80677	80,22	19	04 / 2002	83372	10,27	22	04 / 2002	90A2004	10,421	4	04 / 2002
80719	10,412	2	04 / 2002	83372	40,12	25	04 / 2002	90A2004	10,422	3	04 / 2002
80719	10,421	3	04 / 2002	83372	40,21	24	04 / 2002	90A2007	10,441	7	04 / 2002
80719	10,422	2	04 / 2002	83372	80,11	12	04 / 2002	90A2007	10,442	7	04 / 2002
80731	10,43	5	04 / 2002	83372	80,22	16	04 / 2002	90A2008	20,12	4	04 / 2002
80733	10,43	6	04 / 2002	83375	10,322	1	04 / 2002	90A2008	20,221	10	04 / 2002
80742	50,11	8	04 / 2002	83375	10,323	1	04 / 2002	90A2010	20,12	5	04 / 2002
80751	20,12	1	04 / 2002	83375	10,441	9	04 / 2002	90A2010	20,221	12	04 / 2002
80751	20,221	7	04 / 2002	83375	10,442	9	04 / 2002	90A2011	10,412	9	04 / 2002
80753	20,12	2	04 / 2002	83375	80,314	7	04 / 2002	90A2011	10,421	13	04 / 2002
80753	20,221	8	04 / 2002	83387	40,12	27	04 / 2002	90A2011	10,422	9	04 / 2002
80754	20,12	3	04 / 2002	83387	40,21	12	04 / 2002	90A2013	10,412	4	04 / 2002
80754	20,221	9	04 / 2002	83390	60,7	6	04 / 2002	90A2013	10,421	5	04 / 2002
809035	60,43	2	04 / 2002	83462	60,7	5	04 / 2002	90A2013	10,422	4	04 / 2002
80934	10,26	3	04 / 2002	83544	60,41	27	04 / 2002	90A2014	10,412	5	04 / 2002
80934	10,26	6	04 / 2002	83545	60,131	22	04 / 2002	90A2014	10,421	6	04 / 2002
80934	10,27	4	04 / 2002	83550	20,12	13	04 / 2002	90A2014	10,422	5	04 / 2002
80934	10,27	9	04 / 2002	83550	20,221	18	04 / 2002	90A2015	10,412	6	04 / 2002
80934	80,22	6	04 / 2002	83556	10,25	15	04 / 2002	90A2015	10,421	7	04 / 2002
80935	10,25	2	04 / 2002	83556	10,27	26	04 / 2002	90A2015	10,422	6	04 / 2002
80935	40,21	3	04 / 2002	83556	60,41	15	04 / 2002	90A2016	10,412	7	04 / 2002
80935	80,11	1	04 / 2002	83557	10,25	16	04 / 2002	90A2016	10,421	9	04 / 2002
80943	10,25	4	04 / 2002	83557	10,27	27	04 / 2002	90A2016	10,422	7	04 / 2002
80943	40,21	28	04 / 2002	83557	60,41	16	04 / 2002	90A2018	10,441	2	04 / 2002
80943	60,43	8	04 / 2002	83558	40,21	6	04 / 2002	90A2018	10,442	2	04 / 2002
80943	80,11	9	04 / 2002	83559	40,21	8	04 / 2002	90A2019	10,441	21	04 / 2002
81036	10,311	8	04 / 2002	83560	40,21	7	04 / 2002	90A2019	10,442	21	04 / 2002
81036	10,312	8	04 / 2002	83561	40,21	9	04 / 2002	90A2020	10,441	22	04 / 2002
81036	10,322	18	04 / 2002	83573	10,25	1	04 / 2002	90A2020	10,442	22	04 / 2002
81036	10,323	18	04 / 2002	83573	10,26	1	04 / 2002	90A2021	10,412	22	04 / 2002
81041D	10,322	16	04 / 2002	83573	10,27	1	04 / 2002	90A2021	10,422	22	04 / 2002
81041D	10,323	16	04 / 2002	83573	40,12	23	04 / 2002	90A2022	10,441	8	04 / 2002
81041DX	10,311	1	04 / 2002	83573	40,21	22	04 / 2002	90A2022	10,442	8	04 / 2002
81041DX	10,312	1	04 / 2002	83573	80,11	15	04 / 2002	90A2023	10,441	20	04 / 2002
81041S	10,322	17	04 / 2002	83573	80,22	14	04 / 2002	90A2023	10,442	20	04 / 2002
81041S	10,323	17	04 / 2002	83574	10,25	8	04 / 2002	90A2024	10,441	3	04 / 2002
81041SX	10,311	2	04 / 2002	83574	10,26	11	04 / 2002	90A2024	10,442	3	04 / 2002
81041SX	10,312	2	04 / 2002	83574	10,27	21	04 / 2002	90A2026	10,412	25	04 / 2002
81042	10,311	13	04 / 2002	83574	40,12	24	04 / 2002	90A2027	10,412	26	04 / 2002
81042	10,312	13	04 / 2002	83574	40,21	23	04 / 2002	90A2029	10,421	10	04 / 2002
81043	10,311	10	04 / 2002	83574	80,11	11	04 / 2002	90A2029	10,441	10	04 / 2002
81043	10,312	10	04 / 2002	83574	80,22	17	04 / 2002	90A2029	10,442	10	04 / 2002
81043	10,322	19	04 / 2002	83620	80,7	11	04 / 2002	90A2030	10,421	11	04 / 2002
81043	10,323	19	04 / 2002	83629	40,12	8	04 / 2002	90A2031	10,421	12	04 / 2002
81044	10,311	11	04 / 2002	83653	80,121	7	04 / 2002	90A2032	20,12	16	04 / 2002
81044	10,312	11	04 / 2002	83654	80,121	8	04 / 2002	90A2032	20,221	15	04 / 2002
81044	10,322	20	04 / 2002	83691	10,311	3	04 / 2002	90A2035	10,43	2	04 / 2002
81044	10,323	20	04 / 2002	83691	10,312	3	04 / 2002	90A2037	10,43	10	04 / 2002
81052	10,311	9	04 / 2002	83692	10,311	4	04 / 2002	90A2038	10,43	11	04 / 2002
81052	10,312	9	04 / 2002	83692	10,312	4	04 / 2002	90A2040	10,21	28	04 / 2002
81052	10,322	43	04 / 2002	83823	80,313	11	04 / 2002	90A2040	10,23	15	04 / 2002
81052	10,323	43	04 / 2002	83858	10,25	18	04 / 2002	90A2040	10,24	16	04 / 2002



COD.	TAV.	POS.	EDIZ.	COD.	TAV.	POS.	EDIZ.	COD.	TAV.	POS.	EDIZ.
90A2040	10,412	17	04 / 2002	90D0102	50,12	2	04 / 2002	90H2003	0,51	10	04 / 2002
90A2040	10,421	21	04 / 2002	90D1002	50,21	3	04 / 2002	90H2013	0,51	11	04 / 2002
90A2040	10,422	17	04 / 2002	90D1003	50,13	1	04 / 2002	90H2013	60,14	39	04 / 2002
90A4003	10,311	5	04 / 2002	90D1013	50,21	13	04 / 2002	90H2014	50,22	15	04 / 2002
90A4003	10,312	5	04 / 2002	90D1014	50,22	16	04 / 2002	90H2014	70,1	2	04 / 2002
90A4004	10,311	6	04 / 2002	90D1015	40,11	23	04 / 2002	90H3007	0,32	6	04 / 2002
90A4004	10,312	6	04 / 2002	90D1015	50,22	8	04 / 2002	90H3008	0,32	17	04 / 2002
90A4004	40,13	37	04 / 2002	90D1017	50,22	4	04 / 2002	90H3009	0,32	1	04 / 2002
90A4008	20,12	7	04 / 2002	90D1018	50,22	5	04 / 2002	90H3027	0,32	10	04 / 2002
90A4008	20,221	11	04 / 2002	90D1019	50,22	6	04 / 2002	90H3035	0,32	9	04 / 2002
90A4012	10,311	7	04 / 2002	90D1021	50,21	2	04 / 2002	90H3037	0,32	8	04 / 2002
90A4012	10,312	7	04 / 2002	90D1022	50,21	1	04 / 2002	90H3038	0,32	18	04 / 2002
90A4013	10,311	18	04/2002	90D1024	50,22	1	04 / 2002	90H4002	0,42	13	04 / 2002
90A4013	10,312	18	04 / 2002	90D1027	50,22	9	04 / 2002	90H4003	0,42	15	04 / 2002
90A9205	10,43	12	04 / 2002	90D1028	50,22	14	04 / 2002	90H4012	0,42	8	04 / 2002
90A9205	10,43	7	04 / 2002	90D1030	50,21	4	04 / 2002	90H4014	0,42	10	04 / 2002
90A9205.00	10,43	1	04 / 2002	90D1035	50,11	13	04 / 2002	90H4021	0,42	16	04 / 2002
90A9208	10,412	8	04 / 2002	90D1039	50,22	7	04 / 2002	90H4022	0,42	18	04/2002
90A9208	10,421	12	04 / 2002	90D1043	50,11	19	04 / 2002	90H4023	0,42	1	04 / 2002
90A9208	10,422	8	04 / 2002	90D1044	50,11	12	04 / 2002	90H5015	0,61	13	04 / 2002
90A9208	20,12	15	04 / 2002	90D1045	50,11	24	04 / 2002	90H5028	0,61	6	04 / 2002
90A9208	20,221	14	04 / 2002	90D1046	50,11	11	04 / 2002	90H5035	0,61	12	04 / 2002
90A9409	10,311	16	04 / 2002	90D1048	50,11	23	04 / 2002	90H5038	0,61	5	04 / 2002
90A9409	10,312	16	04 / 2002	90D1049	50,12	1	04 / 2002	90H9301	0,32	12	04 / 2002
90A9411	30,11	12	04 / 2002	90D1050	50,22	2	04 / 2002	90I0102	90,4	12	04 / 2002
90A9412	30,21	2	04 / 2002	90D1051	50,22	3	04 / 2002	90I0103	90,4	14	04 / 2002
90A9413	30,11	24	04 / 2002	90D9116	50,11	10	04 / 2002	90I0104	90,4	13	04 / 2002
90A9414	30,21	25	04 / 2002	90E1009	60,151	20	04 / 2002	90I0105	80,4	9	04/2002
90B0402	10,322	6	04 / 2002	90E1009	60,152	20	04 / 2002	90I0111	90,2	5	04 / 2002
90B0402	10,323	6	04 / 2002	90E1045	60,11	3	04 / 2002	90I0121	60,42	16	04 / 2002
90B0920	10,421	27	04 / 2002	90E1045	60,12	3	04 / 2002	90I0122	60,42	19	04 / 2002
90B0920	10,422	24	04 / 2002	90E1046	60,11	5	04 / 2002	90I0130	60,42	27	04 / 2002
90B1001	30,122	5	04 / 2002	90E1046	60,12	5	04 / 2002	90I0130	80,4	8	04 / 2002
90B1002	30,11	14	04 / 2002	90E1048	60,11	34	04 / 2002	90I0133	90,4	21	04 / 2002
90B1005	30,122	15	04 / 2002	90E1048	60,12	38	04 / 2002	90I0140	60,42	41	04/2002
90B1027	30,11	25	04/2002	90E1049	60,11	32	04 / 2002	90I0143	50,11	18	04 / 2002
90B1027	30,21	26	04/2002	90E1049	60,12	40	04 / 2002	90I0149	80,11	23	04 / 2002
90B1028	10,322	38	04 / 2002	90E1072C	60,11	9	04 / 2002	90I0167	40,21	41	04/2002
90B1028	10,323	38	04 / 2002	90E1072C	60,12	9	04 / 2002	90I0173	90,3	24	04 / 2002
90B1029	30,22	15	04 / 2002	90E1073C	60,11	26	04 / 2002	90I0174	90,3	25	04 / 2002
90B2004	10,421	28	04 / 2002	90E1073C	60,12	26	04 / 2002	90I0176	90,3	21	04 / 2002
90B2004	10,422	25	04 / 2002	90E1073C	60,131	24	04 / 2002	90I0177	90,3	23	04 / 2002
90B2005	10,421	29	04 / 2002	90E1076C	60,11	27	04 / 2002	90I0178	90,3	27	04 / 2002
90B2005	10,422	26	04 / 2002	90E1076C	60,12	27	04 / 2002	90I0179	90,3	26	04 / 2002
90B4003	10,322	4	04 / 2002	90E1076C	60,131	25	04 / 2002	90I0180	60,42	12	04 / 2002
90B4003	10,323	4	04 / 2002	90E1080C	60,12	29	04 / 2002	90I0181	60,42	14	04 / 2002
90B4004	10,322	2	04 / 2002	90E1080C	60,141	33	04 / 2002	90I0182	60,42	13	04 / 2002
90B4004	10,323	2	04 / 2002	90E1083	90,3	35	04 / 2002	90I0183	60,42	26	04 / 2002
90B4005	10,322	22	04 / 2002	90F0912	40,111	9	04 / 2002	90I0183	80,4	10	04/2002
90B4005	10,323	22	04 / 2002	90F1001	40,12	20	04 / 2002	90I0184	60,42	21	04 / 2002
90B4007	10,322	3	04 / 2002	90F1002	40,12	22	04 / 2002	90I0185	60,42	15	04 / 2002
90B4007	10,323	3	04 / 2002	90F1003	40,12	13	04 / 2002	90I0186	60,42	43	04/2002
90B4012	10,322	57	04/2002	90F1004	40,12	14	04 / 2002	90I0186	60,42	8	04 / 2002
90B4012	10,323	57	04/2002	90F1005	40,12	17	04 / 2002	90I0195	60,42	6	04 / 2002
90B4013	10,322	56	04/2002	90F1008	40,12	10	04 / 2002	90I0196	60,42	5	04 / 2002
90B4013	10,323	56	04/2002	90F1009	40,11	13	04 / 2002	90I1102	60,42	31	04/2002
90B4014	10,322	54	04/2002	90F1010	40,11	18	04 / 2002	90I1103	60,42	2	04 / 2002
90B4014	10,323	54	04/2002	90F1011	40,11	19	04 / 2002	90I1104	90,3	29	04 / 2002
90B4015	10,322	53	04/2002	90F1012	40,11	8	04 / 2002	90I1105	90,3	22	04 / 2002
90B4015	10,323	53	04/2002	90F1013	40,11	9	04 / 2002	90I1107	60,42	38	04/2002
90B4016	10,322	55	04/2002	90F1014	40,11	10	04 / 2002	90I1108	60,42	29	04/2002
90B4016	10,323	55	04/2002	90F1015	40,11	16	04 / 2002	90I1109	60,42	39	04/2002
90B4017	10,322	12	04 / 2002	90F1016	40,11	17	04 / 2002	90I1110	60,42	37	04/2002
90B4017	10,323	12	04 / 2002	90F1017	40,12	26	04 / 2002	90I1115	60,42	18	04 / 2002
90B4018	10,322	34	04 / 2002	90F1031	40,11	6	04 / 2002	90I1116	80,4	7	04 / 2002
90B4018	10,323	34	04 / 2002	90F1032	40,11	11	04 / 2002	90I1118	60,42	20	04 / 2002
90B4019	10,322	11	04 / 2002	90F1033	40,11	12	04 / 2002	90I1118	80,4	11	04/2002
90B4019	10,323	11	04 / 2002	90F1041	40,12	30	04 / 2002	90I1122	90,4	11	04 / 2002
90B4020	10,322	5	04 / 2002	90F1042	40,12	31	04 / 2002	90I1123	90,4	20	04 / 2002
90B4020	10,323	5	04 / 2002	90F1043	40,12	6	04 / 2002	90I1124	90,4	19	04 / 2002
90B4021	10,323	47	04 / 2002	90F1044	40,12	7	04 / 2002	90I1125	90,4	27	04 / 2002
90B9102	30,11	23	04 / 2002	90GE1079	60,11	7	04 / 2002	90I1129	60,43	15	04 / 2002
90B9103	30,11	11	04 / 2002	90GE1079	60,12	7	04 / 2002	90I1130	60,43	28	04/2002
90B9103	30,21	1	04 / 2002	90H0100	0,13	31	04 / 2002	90I1131	60,42	17	04 / 2002
90C1004	10,12	1	04 / 2002	90H0401	0,42	11	04 / 2002	90I1139	60,42	7	04 / 2002
90C1004	10,13	1	04 / 2002	90H1002	0,21	1	04 / 2002	90I1141	60,42	40	04/2002
90C10051	10,13	6	04 / 2002	90H1006	0,13	2	04 / 2002	90I1142	60,42	33	04/2002
90C5004	10,311	17	04 / 2002	90H1009	0,13	23	04 / 2002	90I1143	60,42	34	04/2002
90C5004	10,312	17	04 / 2002	90H1010	0,13	39	04 / 2002	90I1144	60,42	32	04/2002
90C5004	10,322	46	04 / 2002	90H1021	0,13	6	04 / 2002	90I1145	60,42	35	04/2002
90C5004	10,323	46	04 / 2002	90H1022	0,13	7	04 / 2002	90I1146	60,42	36	04/2002
90C5012	30,3	7	04/2002	90H1023	0,13	8	04 / 2002	90I9117	60,42	1	04 / 2002
90C5014	30,3	1	04 / 2002	90H1024	0,13	9	04 / 2002	90K0001	80,14	11	04 / 2002
90C5016	30,3	3	04 / 2002	90H1025	0,13	10	04 / 2002	90K1001	80,121	9	04 / 2002
90C5017	30,3	4	04 / 2002	90H1026	0,13	22	04 / 2002	90K1003	80,14	12	04 / 2002
90C5018	30,3	2	04 / 2002	90H1056	0,21	13	04/2002	90K1005	80,14	17	04 / 2002

COD.	TAV.	POS.	EDIZ.	COD.	TAV.	POS.	EDIZ.	COD.	TAV.	POS.	EDIZ.
90K1006	80,14	18	04 / 2002	90M1320	80,31	21	04 / 2002	90P0701	60,12	34	04 / 2002
90K1007	80,14	19	04 / 2002	90M1321	80,31	22	04 / 2002	90P1002	60,151	9	04 / 2002
90K1008	80,14	26	04 / 2002	90M1322	80,31	20	04 / 2002	90P1002	60,152	9	04 / 2002
90K1009	80,14	25	04 / 2002	90M1323	80,31	19	04 / 2002	90P1007	90,3	10	04 / 2002
90K1010	80,14	22	04 / 2002	90M1332	80,314	31	04 / 2002	90P1008	60,42	3	04 / 2002
90K1011	80,14	23	04 / 2002	90M1333	80,314	35	04 / 2002	90P1011	60,42	4	04 / 2002
90K1012	80,14	29	04 / 2002	90M1334	80,314	29	04 / 2002	90P1012	10,26	22	04 / 2002
90K1013	80,14	30	04 / 2002	90M1335	80,314	14	04 / 2002	90P1012	60,41	31	04 / 2002
90K1014	80,14	31	04 / 2002	90M1336	80,314	36	04 / 2002	90P1015	60,151	17	04 / 2002
90K1015	80,14	32	04 / 2002	90M1339	60,151	8	04 / 2002	90P1015	60,152	17	04 / 2002
90K1023	80,14	34	04 / 2002	90M1339	60,152	8	04 / 2002	90P1028	60,132	9	04 / 2002
90K1024	80,14	33	04 / 2002	90M1339	80,314	39	04 / 2002	90P1029	60,21	7	04 / 2002
90K1026	80,14	37	04 / 2002	90M1355	80,31	52	04 / 2002	90P1029	60,22	4	04 / 2002
90K1026	80,14	38	04 / 2002	90M1355	80,31	53	04 / 2002	90P1030	60,151	23	04 / 2002
90K1027	80,14	45	04 / 2002	90M1355	80,31	54	04 / 2002	90P1030	60,152	23	04 / 2002
90K1040	80,14	27	04 / 2002	90M1355	80,31	55	04 / 2002	90P1031	60,21	6	04 / 2002
90K1041	80,14	28	04 / 2002	90M1355V	80,31	56	04 / 2002	90P1031	60,22	3	04 / 2002
90K1076	80,14	24	04 / 2002	90M1355V	80,31	57	04 / 2002	90P1032	60,21	8	04 / 2002
90K1077	80,14	36	04 / 2002	90M1355V	80,31	58	04 / 2002	90P1032	60,22	5	04 / 2002
90K1086	80,14	13	04 / 2002	90M1355V	80,31	59	04 / 2002	90P1037D	60,132	10	04 / 2002
90K2023	80,131	16	04 / 2002	90M2315	80,32	6	04 / 2002	90P1037S	60,132	13	04 / 2002
90K2028	80,131	17	04 / 2002	90M2316	80,32	7	04 / 2002	90P1038	60,151	12	04 / 2002
90K2033	80,131	9	04 / 2002	90M2317	80,32	8	04 / 2002	90P1038	60,152	12	04 / 2002
90K2036	80,131	21	04 / 2002	90M2318	80,32	9	04 / 2002	90P1041D	60,132	16	04/2002
90K2050	80,131	1	04 / 2002	90M2320	80,32	11	04 / 2002	90P1041S	60,132	19	04/2002
90K2051	80,131	3	04 / 2002	90M3001	80,14	16	04 / 2002	90P1607	60,42	22	04 / 2002
90K2054	80,131	5	04 / 2002	90M3002	80,14	44	04 / 2002	90P1608	0,13	34	04 / 2002
90K2056	80,131	2	04 / 2002	90M3002	80,313	7	04 / 2002	90P1609	60,42	11	04 / 2002
90K3002	80,22	3	04 / 2002	90M3005	80,313	19	04 / 2002	90P1622	60,41	35	04 / 2002
90K3003	80,121	10	04 / 2002	90M3006	80,313	20	04 / 2002	90P1623	60,41	36	04 / 2002
90K3004	80,121	11	04 / 2002	90M3501	80,314	19	04 / 2002	90P1624	60,41	37	04 / 2002
90K3005	80,121	12	04 / 2002	90M3502	80,313	25	04 / 2002	90P1627	60,42	42	04/2002
90K3006	80,121	13	04 / 2002	90M3503	80,313	26	04 / 2002	90P1628	60,41	10	04 / 2002
90K3007	80,121	14	04 / 2002	90M3504	80,314	20	04 / 2002	90P1630	60,41	7	04 / 2002
90K3008	80,23	14	04 / 2002	90M4003	80,14	21	04 / 2002	90P1635	60,41	8	04 / 2002
90K3009	80,23	15	04 / 2002	90M4003	80,313	21	04 / 2002	90P1636	60,41	9	04 / 2002
90K3010	80,22	1	04 / 2002	90M4004	80,313	3	04 / 2002	90P1637	90,3	33	04 / 2002
90K9100	80,14	43	04 / 2002	90M4005	80,313	4	04 / 2002	90P1639	60,41	6	04 / 2002
90L1002	10,27	3	04 / 2002	90M4006	80,313	9	04 / 2002	90P1640	70,1	24	04 / 2002
90L1003	10,27	8	04 / 2002	90M4007	80,11	20	04 / 2002	90P1641	70,1	13	04 / 2002
90L1004	10,442	18	04 / 2002	90M4007	80,14	42	04 / 2002	90P1643	60,42	28	04/2002
90L2001	10,441	18	04 / 2002	90M4007	80,313	5	04 / 2002	90P1644	60,41	43	04/2002
90L2002	10,441	19	04 / 2002	90M4009	80,313	10	04 / 2002	90P2001	70,1	4	04 / 2002
90L2007	10,441	25	04/2002	90M5003	80,314	25	04 / 2002	90P2003	70,1	15	04 / 2002
90L2007	10,442	25	04/2002	90M6001	80,11	4	04 / 2002	90P2009	60,41	42	04/2002
90L3002	10,25	3	04 / 2002	90M6001	80,22	7	04 / 2002	90P2010	70,1	23	04 / 2002
90L3003	10,26	4	04 / 2002	90M6003	80,11	21	04 / 2002	90P2011	70,1	9	04 / 2002
90L3004	10,26	16	04 / 2002	90M6006	80,11	5	04 / 2002	90P2012	70,1	16	04 / 2002
90L3005	10,26	17	04 / 2002	90N1009	80,5	3	04 / 2002	90P3001	60,7	8	04 / 2002
90L3007	10,26	8	04 / 2002	90N1025D	80,6	11	04 / 2002	90P3004	60,7	20	04 / 2002
90L3007	10,27	12	04 / 2002	90N1025S	80,6	12	04 / 2002	90P3005	60,7	14	04 / 2002
90L3007	80,22	10	04 / 2002	90N1028	80,6	4	04 / 2002	90P3006	60,7	16	04 / 2002
90L3009	10,26	10	04 / 2002	90N1029	80,6	3	04 / 2002	90P4001	60,61	2	04 / 2002
90L3011	10,26	19	04 / 2002	90N1030	80,6	2	04 / 2002	90P4002	60,61	3	04 / 2002
90L3013	10,25	21	04 / 2002	90N1035	80,6	15	04 / 2002	90P4003	60,61	4	04 / 2002
90L3015	10,26	2	04 / 2002	90N1038	80,5	4	04 / 2002	90P4004	60,61	5	04 / 2002
90L3017	10,26	7	04 / 2002	90N1039	80,5	5	04 / 2002	90P4005	60,61	6	04 / 2002
90L3018	10,26	5	04 / 2002	90N1040	80,5	6	04 / 2002	90P4006	60,61	7	04 / 2002
90L4003	40,21	33	04 / 2002	90N1041	80,5	7	04 / 2002	90P4007	60,61	8	04 / 2002
90L4004	40,21	21	04 / 2002	90N1162	60,21	2	04 / 2002	90P4008	60,61	9	04 / 2002
90L4006	40,21	1	04 / 2002	90N1502	80,7	7	04 / 2002	90P4010	60,61	11	04 / 2002
90L4007	30,21	12	04 / 2002	90N1506D	80,7	1	04 / 2002	90P4019	60,62	5	04 / 2002
90L4008	40,21	42	04/2002	90N1506S	80,7	16	04/2002	90P4023	60,61	12	04 / 2002
90L4009	40,21	32	04 / 2002	90N1507	80,7	18	04/2002	90P4051	60,62	12	04 / 2002
90L4010	40,21	39	04/2002	90N1508	80,7	15	04/2002	90P4052	60,62	13	04 / 2002
90L5007	0,13	27	04 / 2002	90N2001	10,283	1	04 / 2002	90P4053	60,62	3	04 / 2002
90L5007	60,43	27	04 / 2002	90N2004	0,22	5	04 / 2002	90P4054	60,62	4	04 / 2002
90L5009	0,13	30	04 / 2002	90N2005	10,283	6	04 / 2002	90P4070	60,31	5	04 / 2002
90L5011	0,13	29	04 / 2002	90N2010	10,442	30	04/2002	90P4070	60,32	15	04 / 2002
90L6001	80,22	15	04 / 2002	90N2011	0,61	1	04 / 2002	90P4070	60,41	4	04 / 2002
90L6002	80,11	3	04 / 2002	90N2012	0,61	9	04 / 2002	90P4070	60,62	8	04 / 2002
90L8001	0,13	37	04 / 2002	90N2021	60,11	37	04/2002	90P4071	60,61	1	04 / 2002
90L8002	0,13	38	04 / 2002	90N2021	60,12	43	04/2002	90P4077	60,61	10	04 / 2002
90L9100	10,27	2	04 / 2002	90N2027	90,4	28	04 / 2002	90P5007	60,52	7	04 / 2002
90L9103	10,27	7	04 / 2002	90N9162	80,6	1	04 / 2002	90P5008	60,52	8	04 / 2002
90L9601	80,22	2	04 / 2002	90N9403	90,1	3	04 / 2002	90P5017	60,512	6	04 / 2002
90M0601	80,11	24	04 / 2002	90N9404	90,1	2	04 / 2002	90P5018	60,512	5	04 / 2002
90M1023	80,11	19	04 / 2002	90P0101	60,132	11	04 / 2002	90P5024	60,511	3	04 / 2002
90M1312	80,31	47	04 / 2002	90P0101	60,132	14	04 / 2002	90P5024	60,512	4	04 / 2002
90M1312V	80,31	51	04 / 2002	90P0101	60,132	17	04/2002	90P5025	60,511	2	04 / 2002
90M1313	80,31	44	04 / 2002	90P0101	60,132	20	04/2002	90P5025	60,512	3	04 / 2002
90M1313V	80,31	48	04 / 2002	90P0102D	60,132	12	04 / 2002	90P5026	60,511	5	04 / 2002
90M1314	80,31	46	04 / 2002	90P0102S	60,132	15	04/2002	90P5027	60,511	4	04 / 2002
90M1314V	80,31	50	04 / 2002	90P0103D	60,132	18	04/2002	90P5028	60,511	12	04 / 2002
90M1318	80,31	45	04 / 2002	90P0103S	60,132	21	04/2002	90P5028	60,512	13	04 / 2002
90M1318V	80,31	49	04 / 2002	90P0700	60,12	33	04 / 2002	90P6019	60,32	2	04 / 2002



COD.	TAV.	POS.	EDIZ.	COD.	TAV.	POS.	EDIZ.	COD.	TAV.	POS.	EDIZ.
90P6022	60,32	3	04 / 2002	90R1025	80,21	17	04 / 2002	90R1066	10,23	16	04 / 2002
90P6028	60,21	9	04/2002	90R1026	10,21	34	04 / 2002	90R1067	10,24	27	04 / 2002
90P6045	60,511	1	04 / 2002	90R1026	10,23	28	04 / 2002	90R1067	80,21	31	04 / 2002
90P6045	60,512	1	04 / 2002	90R1026	10,24	7	04 / 2002	90R1068	10,23	17	04 / 2002
90P6046	60,512	2	04 / 2002	90R1026	10,412	12	04 / 2002	90R1069	10,23	18	04 / 2002
90P6047	60,52	1	04 / 2002	90R1026	10,421	16	04 / 2002	90R1072	10,21	24	04 / 2002
90P6048	60,52	2	04 / 2002	90R1026	10,422	12	04 / 2002	90R1073	10,23	19	04 / 2002
90P6049	60,52	3	04 / 2002	90R1026	80,21	18	04 / 2002	90R1075	10,23	20	04 / 2002
90P6056	60,41	18	04 / 2002	90R1027	10,21	35	04 / 2002	90R1076	10,23	21	04 / 2002
90P6057	60,41	20	04 / 2002	90R1027	10,23	29	04 / 2002	90R1077	10,23	6	04 / 2002
90P6060	60,31	8	04 / 2002	90R1028	10,21	13	04 / 2002	90R1079	10,21	25	04 / 2002
90P6061	60,31	9	04 / 2002	90R1028	10,23	30	04 / 2002	90R1079	10,22	4	04 / 2002
90P6062	60,31	10	04 / 2002	90R1029	10,22	5	04 / 2002	90R1079	10,23	22	04 / 2002
90P6063	60,31	4	04 / 2002	90R1030	10,21	14	04 / 2002	90R1079	10,24	17	04 / 2002
90P6067	60,41	1	04 / 2002	90R1031	10,24	8	04 / 2002	90R1079	80,121	33	04 / 2002
90P7015	60,131	17	04 / 2002	90R1031	80,121	22	04 / 2002	90R1079	80,21	32	04 / 2002
90P7016	60,131	32	04 / 2002	90R1031	80,21	19	04 / 2002	90R1088	80,21	10	04 / 2002
90P7016	60,141	22	04 / 2002	90R1032	10,21	12	04 / 2002	90S3001	10,283	9	04 / 2002
90P7018D	60,131	20	04 / 2002	90R1032	10,412	20	04 / 2002	90S9125D	80,7	2	04 / 2002
90P7018S	60,131	21	04 / 2002	90R1032	10,421	25	04 / 2002	90S9125S	80,7	3	04 / 2002
90P7024	60,141	10	04 / 2002	90R1032	10,422	20	04 / 2002	90T1507	0,61	7	04 / 2002
90P7037D	60,11	29	04 / 2002	90R1032	80,121	19	04 / 2002	90T1700	80,31	23	04 / 2002
90P7037D	60,12	35	04 / 2002	90R1032	80,21	13	04 / 2002	90T1700	80,32	4	04 / 2002
90P7037S	60,11	36	04/2002	90R1033	10,21	15	04 / 2002	90T3055	80,31	34	04 / 2002
90P7037S	60,12	42	04/2002	90R1034	10,24	25	04 / 2002	90T3055V	80,31	35	04 / 2002
90P7045	60,141	13	04 / 2002	90R1034	80,121	23	04 / 2002	90T3090	80,32	28	04/2002
90P7046D	60,131	23	04 / 2002	90R1034	80,21	20	04 / 2002	90T3090V	80,32	29	04/2002
90P7046S	60,131	39	04 / 2002	90R1035	10,21	16	04 / 2002	90T3099	80,32	27	04/2002
90P7049D	60,132	1	04 / 2002	90R1035	10,23	31	04 / 2002	90T5000	80,9	4	04 / 2002
90P7049S	60,132	2	04 / 2002	90R1035	10,24	9	04 / 2002	90T5005	80,9	2	04 / 2002
90P9205	70,1	17	04 / 2002	90R1035	10,412	21	04 / 2002	90T6001	80,8	1	04 / 2002
90P9303	60,7	1	04 / 2002	90R1035	10,421	26	04 / 2002	91C1005	10,12	4	04 / 2002
90P9610	60,41	21	04 / 2002	90R1035	10,422	21	04 / 2002	91C1005	10,13	4	04 / 2002
90P9732	60,131	1	04 / 2002	90R1035	80,121	24	04 / 2002	91C5001	30,3	6	04/2002
90R1002	10,21	26	04 / 2002	90R1035	80,21	21	04 / 2002	91C5002	30,3	5	04 / 2002
90R1002	10,24	1	04 / 2002	90R1037	10,24	10	04 / 2002	91H0501	0,61	19	04 / 2002
90R1002	80,121	15	04 / 2002	90R1037	80,121	25	04 / 2002	91H1029	0,13	1	04 / 2002
90R1002	80,21	7	04 / 2002	90R1037	80,21	22	04 / 2002	91H1031	0,13	43	04 / 2002
90R1003	10,23	23	04 / 2002	90R1039	10,23	32	04 / 2002	91H1032	0,13	3	04 / 2002
90R1004	10,22	1	04 / 2002	90R1040	10,23	33	04 / 2002	91H1034	80,131	4	04 / 2002
90R1005	10,22	2	04 / 2002	90R1044	10,24	26	04 / 2002	91H1035	0,13	28	04 / 2002
90R1006	10,22	9	04 / 2002	90R1044	80,21	23	04 / 2002	91H2006	0,521	16	04 / 2002
90R1007	10,22	11	04 / 2002	90R1045	10,21	17	04 / 2002	91H2007	0,521	17	04 / 2002
90R1009	10,22	3	04 / 2002	90R1046	10,21	18	04 / 2002	91H2012	0,521	1	04 / 2002
90R1010	10,21	27	04 / 2002	90R1047	10,21	19	04 / 2002	91H2013D	0,521	29	04/2002
90R1011	10,24	2	04 / 2002	90R1047	10,23	34	04 / 2002	91H2013S	0,521	25	04 / 2002
90R1011	80,121	16	04 / 2002	90R1047	10,24	11	04 / 2002	91H2014	0,521	20	04 / 2002
90R1011	80,21	8	04 / 2002	90R1047	80,121	26	04 / 2002	91H2015	0,521	21	04/2002
90R1012	10,24	22	04 / 2002	90R1047	80,21	24	04 / 2002	91H3002	0,32	16	04 / 2002
90R1012	80,21	9	04 / 2002	90R1048	10,21	20	04 / 2002	91H3006	0,32	15	04 / 2002
90R1013	10,21	5	04 / 2002	90R1048	10,23	11	04 / 2002	91H3017	70,1	19	04 / 2002
90R1016	10,21	29	04 / 2002	90R1048	10,24	12	04 / 2002	91H3018	0,32	5	04 / 2002
90R1016	10,23	24	04 / 2002	90R1048	80,121	27	04 / 2002	91H3019	0,32	7	04 / 2002
90R1017	10,21	30	04 / 2002	90R1048	80,21	25	04 / 2002	91H4002	0,42	21	04/2002
90R1017	10,23	25	04 / 2002	90R1049	10,23	12	04 / 2002	91H4004	0,42	4	04 / 2002
90R1017	10,24	3	04 / 2002	90R1050	10,24	13	04 / 2002	91H4005	0,42	9	04 / 2002
90R1017	80,121	17	04 / 2002	90R1050	80,121	28	04 / 2002	91H4006	0,521	2	04 / 2002
90R1017	80,21	11	04 / 2002	90R1050	80,21	26	04 / 2002	91H5000	0,61	22	04 / 2002
90R1018	10,23	26	04 / 2002	90R1051	10,23	13	04 / 2002	91H5001	0,61	14	04 / 2002
90R1019	10,21	31	04 / 2002	90R1052	10,24	14	04 / 2002	91H5002	0,61	15	04 / 2002
90R1019	10,24	4	04 / 2002	90R1052	80,121	29	04 / 2002	91H5004	0,61	18	04 / 2002
90R1019	80,121	18	04 / 2002	90R1052	80,21	27	04 / 2002	91H5005	0,61	16	04 / 2002
90R1019	80,21	12	04 / 2002	90R1053	10,23	14	04 / 2002	91H5006	0,61	17	04 / 2002
90R1020	10,21	11	04 / 2002	90R1054	10,24	15	04 / 2002	91H5009	0,61	26	04/2002
90R1020	10,24	5	04 / 2002	90R1054	80,121	30	04 / 2002	91H5010	0,61	24	04 / 2002
90R1020	10,412	19	04 / 2002	90R1054	80,21	28	04 / 2002	91H5011	0,61	23	04 / 2002
90R1020	10,421	24	04 / 2002	90R1055	10,21	2	04 / 2002	91H9202	0,521	15	04 / 2002
90R1020	10,422	19	04 / 2002	90R1055	10,23	1	04 / 2002	91H9500	0,61	4	04 / 2002
90R1020	80,121	20	04 / 2002	90R1055	10,24	20	04 / 2002	91I1006	90,3	8	04 / 2002
90R1020	80,21	14	04 / 2002	90R1055	10,25	13	04 / 2002	91I1007	90,3	7	04 / 2002
90R1021	80,121	21	04 / 2002	90R1055	10,26	20	04 / 2002	91I1008	90,3	9	04 / 2002
90R1021	80,21	15	04 / 2002	90R1055	10,27	24	04 / 2002	91I1009	90,4	26	04 / 2002
90R1023	10,21	32	04 / 2002	90R1055	80,121	31	04 / 2002	91I1010	90,4	25	04 / 2002
90R1024	10,21	6	04 / 2002	90R1055	80,21	29	04 / 2002	91I9101	60,41	44	04/2002
90R1024	10,23	5	04 / 2002	90R1055	80,22	18	04 / 2002	91L5001	60,43	29	04/2002
90R1024	10,24	24	04 / 2002	90R1056	10,23	3	04 / 2002	91L5002	60,43	30	04/2002
90R1024	10,412	10	04 / 2002	90R1057	10,21	3	04 / 2002	91L8000	0,13	36	04 / 2002
90R1024	10,421	14	04 / 2002	90R1058	10,24	18	04 / 2002	91M2300	80,32	23	04/2002
90R1024	10,422	10	04 / 2002	90R1058	80,121	32	04 / 2002	91M2301	80,32	22	04/2002
90R1024	80,21	16	04 / 2002	90R1058	80,21	30	04 / 2002	91M6002	80,11	22	04 / 2002
90R1025	10,21	33	04 / 2002	90R1059	10,22	6	04 / 2002	91N2005	0,21	8	04 / 2002
90R1025	10,23	27	04 / 2002	90R1060	10,22	7	04 / 2002	91N2007	0,521	27	04 / 2002
90R1025	10,24	6	04 / 2002	90R1061	10,22	8	04 / 2002	91N2008	0,51	15	04/2002
90R1025	10,412	11	04 / 2002	90R1063	10,21	21	04 / 2002	91N9201	0,51	1	04 / 2002
90R1025	10,421	15	04 / 2002	90R1064	10,21	22	04 / 2002	91P2001	70,1	3	04 / 2002
90R1025	10,422	11	04 / 2002	90R1065	10,21	23	04 / 2002	91P4017	60,62	10	04 / 2002

COD.	TAV.	POS.	EDIZ.	COD.	TAV.	POS.	EDIZ.	COD.	TAV.	POS.	EDIZ.
91P4018	60,62	9	04 / 2002	A2017	80,21	33	04 / 2002	B6013	30,122	9	04 / 2002
91P4020	60,62	2	04 / 2002	A2033	10,22	12	04 / 2002	B6013	30,22	9	04 / 2002
91P4030	60,62	11	04 / 2002	A2033	10,322	36	04 / 2002	B6014	30,122	1	04 / 2002
91P4031	60,62	1	04 / 2002	A2033	10,323	36	04 / 2002	B6014	30,22	1	04 / 2002
91P6002	60,41	13	04 / 2002	A2040	80,23	8	04 / 2002	B6015	30,122	2	04 / 2002
91P9601	60,41	25	04 / 2002	A2041	80,23	9	04 / 2002	B6015	30,22	2	04 / 2002
91S3000	0,22	1	04 / 2002	A2053	10,22	13	04 / 2002	B6016	30,122	3	04 / 2002
92A1001	30,22	5	04 / 2002	A2055	10,22	10	04 / 2002	B6016	30,22	3	04 / 2002
92B1006	30,11	10	04 / 2002	A2057	10,22	14	04 / 2002	B6017	30,122	4	04 / 2002
92B9402	10,322	35	04 / 2002	A2058	10,22	15	04 / 2002	B6017	30,22	4	04 / 2002
92B9402	10,323	35	04 / 2002	A2061	10,22	16	04 / 2002	B6028	30,122	16	04 / 2002
92B9402	40,111	1	04 / 2002	A2062	10,22	17	04 / 2002	B6028	30,22	16	04 / 2002
92F0101	40,111	7	04 / 2002	A3010	10,21	4	04 / 2002	B6035	30,11	7	04 / 2002
92F0102	40,111	6	04 / 2002	A3010	10,23	4	04 / 2002	B6035	30,21	17	04 / 2002
92F0107	40,13	6	04 / 2002	A3010	10,24	21	04 / 2002	B6036	30,11	6	04 / 2002
92F0108D	40,13	8	04 / 2002	A3010	10,441	5	04 / 2002	B6036	30,21	15	04 / 2002
92F0108S	40,13	9	04 / 2002	A3010	10,442	5	04 / 2002	B6037	30,11	19	04 / 2002
92F1001	40,111	10	04 / 2002	A3010	80,121	35	04 / 2002	B6037	30,21	16	04 / 2002
92F1002	40,111	11	04 / 2002	A3010	80,21	34	04 / 2002	B7006	50,13	2	04 / 2002
92F1003	40,13	38	04 / 2002	A4001	80,23	10	04 / 2002	B7007	50,13	3	04 / 2002
92F1004	40,13	39	04 / 2002	A4002	80,23	12	04 / 2002	B9103	50,22	17	04 / 2002
92F1020	10,322	40	04 / 2002	A4003	80,23	13	04 / 2002	B9117	50,13	6	04 / 2002
92F1020	10,323	40	04 / 2002	A4101	80,23	11	04 / 2002	B9121	80,6	20	04 / 2002
92H2002	0,51	2	04 / 2002	A7005	20,12	8	04 / 2002	C1003	40,13	24	04 / 2002
92H2007	0,51	7	04 / 2002	A7005	20,221	1	04 / 2002	C1004	40,13	25	04 / 2002
92H2008	0,51	8	04 / 2002	A9014	0,13	32	04 / 2002	C1005	40,13	26	04 / 2002
92H2009	0,51	6	04 / 2002	A9014	10,311	14	04 / 2002	C1006	40,13	27	04 / 2002
92H2010	0,51	3	04 / 2002	A9014	10,312	14	04 / 2002	C1007	40,13	20	04 / 2002
92H4007	80,314	18	04 / 2002	A9014	50,22	18	04 / 2002	C1008	40,13	28	04 / 2002
92L4011	40,21	38	04 / 2002	A9016	10,43	3	04 / 2002	C1009	40,13	19	04 / 2002
92L4012	40,21	37	04 / 2002	A9017	10,43	4	04 / 2002	C1010	40,13	11	04 / 2002
92L4014	40,21	34	04 / 2002	A9503	10,412	18	04 / 2002	C1011	40,13	12	04 / 2002
92L4015	40,21	35	04 / 2002	A9503	10,421	22	04 / 2002	C1012	40,13	16	04 / 2002
92L4016	40,21	36	04 / 2002	A9503	10,422	18	04 / 2002	C1013	40,13	17	04 / 2002
92P1602	60,41	41	04 / 2002	A9540	10,441	13	04 / 2002	C1014	40,13	15	04 / 2002
92P1604	60,42	23	04 / 2002	A9540	10,442	13	04 / 2002	C1015	40,13	31	04 / 2002
92P3001	60,7	17	04 / 2002	A9540	90,3	14	04 / 2002	C1016	40,13	14	04 / 2002
92P3002	60,7	22	04 / 2002	A9542	10,441	24	04 / 2002	C1017	40,13	13	04 / 2002
92P6016	60,42	30	04 / 2002	A9542	10,442	24	04 / 2002	C1018	40,13	36	04 / 2002
92P6017	10,441	31	04 / 2002	A9545	10,441	1	04 / 2002	C1019	40,13	23	04 / 2002
92P6017	90,3	12	04 / 2002	A9545	10,442	1	04 / 2002	C1020	40,13	21	04 / 2002
92P7001	60,131	29	04 / 2002	B1002	10,322	37	04 / 2002	C1021	40,13	22	04 / 2002
92P7001	60,141	20	04 / 2002	B1002	10,323	37	04 / 2002	C1022	40,13	30	04 / 2002
92P7003	60,131	3	04 / 2002	B1003	10,21	7	04 / 2002	C1023	40,13	29	04 / 2002
92P7003	60,141	1	04 / 2002	B1003	10,24	29	04 / 2002	C1025	40,13	32	04 / 2002
92P7004D	60,131	9	04 / 2002	B1003	10,322	7	04 / 2002	C1026	40,13	33	04 / 2002
92P7004D	60,141	7	04 / 2002	B1003	10,323	7	04 / 2002	C1027	40,13	34	04 / 2002
92P7004S	60,131	10	04 / 2002	B1003	80,121	36	04 / 2002	C1028	40,13	35	04 / 2002
92P7005	60,131	13	04 / 2002	B1003	80,21	35	04 / 2002	C1029	40,13	10	04 / 2002
92P7005	60,141	9	04 / 2002	B1004	10,322	8	04 / 2002	C1037	40,13	4	04 / 2002
92P7006	60,131	28	04 / 2002	B1004	10,323	8	04 / 2002	C1039	40,13	18	04 / 2002
92P7006	60,141	17	04 / 2002	B1005	10,322	9	04 / 2002	C1054	40,13	5	04 / 2002
92P7007D	60,131	33	04 / 2002	B1005	10,322	9	04 / 2002	C1055	40,13	7	04 / 2002
92P7007D	60,141	23	04 / 2002	B1006	10,322	10	04 / 2002	C3005	40,111	5	04 / 2002
92P7007S	60,131	34	04 / 2002	B1006	10,323	10	04 / 2002	C3006	40,111	4	04 / 2002
92P7009	60,131	15	04 / 2002	B1011	10,322	32	04 / 2002	C3100	40,111	8	04 / 2002
92P7009	60,141	11	04 / 2002	B1011	10,323	32	04 / 2002	C6000	80,314	6	04 / 2002
92P7010	60,131	11	04 / 2002	B1012	10,322	31	04 / 2002	C6001	80,314	13	04 / 2002
92P7010	60,141	8	04 / 2002	B1012	10,323	31	04 / 2002	C6002	80,314	8	04 / 2002
92P7012	60,131	16	04 / 2002	B1013	10,322	41	04 / 2002	C6003	80,314	9	04 / 2002
92P7012	60,141	12	04 / 2002	B1013	10,323	41	04 / 2002	C6004	80,314	12	04 / 2002
92P7013	60,131	8	04 / 2002	B1014	10,322	33	04 / 2002	C7005	80,11	13	04 / 2002
92P7013	60,141	6	04 / 2002	B1014	10,323	33	04 / 2002	C7006	80,11	2	04 / 2002
92P7014	60,131	12	04 / 2002	B1017	10,322	13	04 / 2002	C7009	80,11	18	04 / 2002
92P7017	60,132	5	04 / 2002	B1017	10,323	13	04 / 2002	C7010	80,313	23	04 / 2002
92P7017	60,141	16	04 / 2002	B1020	10,322	26	04 / 2002	C7013	80,313	15	04 / 2002
92P7017	60,31	2	04 / 2002	B1020	10,322	29	04 / 2002	C7014	80,313	14	04 / 2002
92P7017	60,32	8	04 / 2002	B1020	10,323	26	04 / 2002	C7034	80,314	1	04 / 2002
92T3014	80,31	29	04 / 2002	B1020	10,323	29	04 / 2002	C7035	80,314	2	04 / 2002
94H2007	0,521	14	04 / 2002	B1022	10,322	23	04 / 2002	C7036	80,14	40	04 / 2002
94H2008	0,521	11	04 / 2002	B1022	10,323	23	04 / 2002	C7037	80,313	2	04 / 2002
94H5001	60,43	16	04 / 2002	B1023	10,322	30	04 / 2002	C7038	80,313	1	04 / 2002
94P6000	60,41	12	04 / 2002	B1023	10,323	30	04 / 2002	C7501	80,121	37	04 / 2002
94P6001	60,41	11	04 / 2002	B1024	10,322	42	04 / 2002	C7513	80,14	46	04 / 2002
A1013	90,1	7	04 / 2002	B1024	10,323	42	04 / 2002	C7530	80,14	20	04 / 2002
A1014	90,1	10	04 / 2002	B1026	10,322	24	04 / 2002	C8006	80,314	11	04 / 2002
A1022	0,22	2	04 / 2002	B1026	10,323	24	04 / 2002	C8007	80,314	10	04 / 2002
A1023	0,61	8	04 / 2002	B1027	10,322	27	04 / 2002	C8018	80,31	13	04 / 2002
A1028	80,4	1	04 / 2002	B1027	10,323	27	04 / 2002	C8020	80,31	1	04 / 2002
A1048	80,6	5	04 / 2002	B1028	40,111	2	04 / 2002	C8025	80,314	23	04 / 2002
A2005	80,23	7	04 / 2002	B4002	10,322	25	04 / 2002	C8029	80,31	12	04 / 2002
A2017	10,23	7	04 / 2002	B4002	10,323	25	04 / 2002	C8033	80,31	4	04 / 2002
A2017	10,24	28	04 / 2002	B4003	10,322	28	04 / 2002	C8034	80,31	5	04 / 2002
A2017	10,441	4	04 / 2002	B4003	10,323	28	04 / 2002	C8037	80,31	6	04 / 2002
A2017	10,442	4	04 / 2002	B6012	30,122	10	04 / 2002	C8038	80,31	7	04 / 2002
A2017	80,121	34	04 / 2002	B6012	30,22	10	04 / 2002	CASSA00071	80,31	36	04 / 2002

COD.	TAV.	POS.	EDIZ.	COD.	TAV.	POS.	EDIZ.	COD.	TAV.	POS.	EDIZ.
CASSA00095	80,31	38	04 / 2002	E4110	60,42	24	04 / 2002	I5008	90,1	6	04 / 2002
CASSA00100	80,31	39	04 / 2002	E4111	10,441	14	04 / 2002	I5009	90,3	5	04 / 2002
CASSA00124	80,31	37	04 / 2002	E4111	10,442	14	04 / 2002	I5009	90,4	5	04 / 2002
CASSA00148	80,32	14	04 / 2002	E4111	60,41	29	04 / 2002	I5010	90,3	6	04 / 2002
CASSA00149	80,32	13	04 / 2002	E4119	60,11	25	04 / 2002	I5010	90,4	6	04 / 2002
CASSA00150	80,32	15	04 / 2002	E4119	60,12	25	04 / 2002	I5011	90,3	4	04 / 2002
CASSA00151	80,32	16	04 / 2002	E4120	60,11	11	04 / 2002	I5011	90,4	4	04 / 2002
CATBK00000	60,11	15	04 / 2002	E4120	60,12	11	04 / 2002	I5014	90,3	3	04 / 2002
D1001	10,25	19	04 / 2002	E4120V	60,11	12	04 / 2002	I5014	90,4	3	04 / 2002
D1003	10,25	7	04 / 2002	E4120V	60,12	12	04 / 2002	K1018	80,14	14	04 / 2002
D2003	10,27	20	04 / 2002	E4121	60,11	13	04 / 2002	K1018	80,313	6	04 / 2002
D2004	10,27	15	04 / 2002	E4121	60,12	13	04 / 2002	K1126	80,14	15	04 / 2002
D2004	80,22	20	04 / 2002	E4121V	60,11	14	04 / 2002	K2075	60,141	27	04 / 2002
D4001	40,21	4	04 / 2002	E4121V	60,12	14	04 / 2002	K2079	60,43	23	04 / 2002
D4002	40,21	5	04 / 2002	E4122	60,131	18	04 / 2002	K2080	60,43	24	04 / 2002
D4003	40,21	14	04 / 2002	E4124	60,151	21	04 / 2002	K2081	60,43	22	04 / 2002
D4008	40,21	2	04 / 2002	E4124	60,152	21	04 / 2002	K2085	60,141	28	04 / 2002
D4012	40,12	15	04 / 2002	E4125	60,32	1	04 / 2002	K2085	60,151	18	04 / 2002
D4012	60,41	22	04 / 2002	E4128	60,141	26	04 / 2002	K2085	60,152	18	04 / 2002
D4013	40,12	9	04 / 2002	E4128	60,22	7	04 / 2002	K2085	80,314	33	04 / 2002
D4016	40,12	1	04 / 2002	E4129	60,141	18	04 / 2002	K2113	90,3	13	04 / 2002
D4032	10,25	6	04 / 2002	E4130	60,52	5	04 / 2002	K2156	60,141	31	04 / 2002
D4032	10,26	9	04 / 2002	E4131	60,52	4	04 / 2002	OSSAN00050	20,221	13	04 / 2002
D4032	10,27	14	04 / 2002	E4134	60,32	19	04 / 2002	OSSAP00050	20,12	6	04 / 2002
D4032	30,11	8	04 / 2002	E4136	60,32	11	04 / 2002	OSSAP00059	20,12	19	04 / 2002
D4032	30,21	18	04 / 2002	E4159	60,151	13	04 / 2002	PONAE00052	20,21	1	04 / 2002
D4032	40,21	17	04 / 2002	E4159	60,152	13	04 / 2002	PONAE00054	20,21	2	04 / 2002
D4032	60,131	31	04 / 2002	E4159	60,41	40	04/2002	PONTP00069	20,11	1	04 / 2002
D4032	60,141	21	04 / 2002	E4162	60,41	28	04 / 2002	PONTP00083	20,11	2	04 / 2002
D4032	60,43	7	04 / 2002	E4169	60,21	10	04/2002	QT1295	10,322	51	04/2002
D4032	80,11	10	04 / 2002	E4169	60,21	3	04 / 2002	QT1295	10,323	51	04/2002
D4032	80,22	11	04 / 2002	E4169	80,7	9	04 / 2002	QT1296	10,322	50	04/2002
D4034	10,322	39	04 / 2002	E4174	90,3	15	04 / 2002	QT1296	10,323	52	04/2002
D4034	10,323	39	04 / 2002	E4175	60,31	1	04 / 2002	QT1299	10,441	30	04/2002
D8012	0,51	13	04 / 2002	E4175	60,32	7	04 / 2002	QT1312	10,21	36	04/2002
D8017	70,1	1	04 / 2002	E4175	60,41	3	04 / 2002	QT1312	10,23	35	04/2002
D8020	40,11	25	04 / 2002	E5001	90,3	17	04 / 2002	QT1312	10,24	35	04/2002
D8032	0,521	5	04 / 2002	E5002	90,3	18	04 / 2002	QT1312	10,25	22	04/2002
D8033	0,21	2	04 / 2002	ED4127	60,141	25	04 / 2002	QT1312	10,26	24	04/2002
D8034	0,21	3	04 / 2002	ED4127	60,22	8	04 / 2002	QT1312	10,27	30	04/2002
D8039	80,314	30	04 / 2002	F1000	90,4	7	04 / 2002	QT1312	80,121	38	04/2002
D8043	80,313	22	04 / 2002	F2000	90,3	11	04 / 2002	QT1312	80,21	36	04/2002
D8044	0,51	12	04 / 2002	F3011	10,27	16	04 / 2002	QT1312	80,22	23	04 / 2002
D8050	0,42	17	04/2002	F3011	40,21	18	04 / 2002	RIDUT00050	10,12	5	04 / 2002
D8050	0,521	24	04 / 2002	F3011	80,22	22	04 / 2002	RIDUT00050	10,13	5	04 / 2002
DIFFA00053	10,421	1	04 / 2002	F3011	80,313	24	04 / 2002	RIDUT00050	80,23	5	04 / 2002
DIFFA00056	10,422	1	04 / 2002	F3012	40,21	26	04 / 2002				
DIFFP00052	10,412	1	04 / 2002	G3001	60,41	17	04 / 2002				
E4013	50,11	7	04 / 2002	G5001	70,2	3	04 / 2002				
E4021	50,11	16	04 / 2002	G5002	70,2	4	04 / 2002				
E4022	50,11	15	04 / 2002	G5003N	70,2	2	04 / 2002				
E4023	50,11	14	04 / 2002	G6001	60,7	15	04 / 2002				
E4024	50,11	1	04 / 2002	G6004	60,7	7	04 / 2002				
E4025	50,11	5	04 / 2002	G7003	60,7	19	04 / 2002				
E4041	70,1	12	04 / 2002	G8000	40,11	24	04 / 2002				
E4042	70,1	11	04 / 2002	G8001	40,11	20	04 / 2002				
E4046	60,43	3	04 / 2002	G8002	40,11	21	04 / 2002				
E4047	60,43	4	04 / 2002	G8003	40,11	22	04 / 2002				
E4050	60,43	1	04 / 2002	GE4124	60,131	36	04 / 2002				
E4052	60,41	5	04 / 2002	H2024	60,61	15	04/2002				
E4060	60,132	8	04 / 2002	H2025	60,61	13	04/2002				
E4061	60,132	4	04 / 2002	H2026	60,61	14	04/2002				
E4066	60,32	4	04 / 2002	H5107	80,131	22	04 / 2002				
E4068	60,151	1	04 / 2002	H5114	80,14	41	04 / 2002				
E4068	60,152	1	04 / 2002	H5123	80,11	16	04 / 2002				
E4070	80,7	14	04 / 2002	H5123	80,14	35	04 / 2002				
E4071	60,131	30	04 / 2002	H5129	80,11	17	04 / 2002				
E4076	60,151	14	04 / 2002	H7002	0,13	40	04 / 2002				
E4076	60,152	14	04 / 2002	H7003	0,13	44	04 / 2002				
E4080	60,7	3	04 / 2002	H7005	0,13	45	04 / 2002				
E4081	60,7	2	04 / 2002	H7006	0,13	42	04 / 2002				
E4082	60,7	4	04 / 2002	H7007	0,13	41	04 / 2002				
E4083	60,151	19	04 / 2002	I-10275501	0,13	4	04 / 2002				
E4083	60,152	19	04 / 2002	I-93809147	0,521	12	04 / 2002				
E4086	60,11	28	04 / 2002	I-93811590	0,51	14	04 / 2002				
E4086	60,12	28	04 / 2002	I-93811591	0,521	26	04 / 2002				
E4086	70,1	20	04 / 2002	I-93815303	0,521	22	04 / 2002				
E4088	70,2	1	04 / 2002	I-93822770	0,521	23	04 / 2002				
E4095	60,41	14	04 / 2002	I1003	90,3	2	04 / 2002				
E4095	60,43	25	04 / 2002	I1003	90,4	2	04 / 2002				
E4095	60,52	6	04 / 2002	I1004	80,6	7	04 / 2002				
E4095	70,1	18	04 / 2002	I1004	90,3	1	04 / 2002				
E4097	80,7	12	04 / 2002	I1004	90,4	1	04 / 2002				
E4098	80,7	13	04 / 2002	I1007	40,21	40	04/2002				
E4100	60,43	19	04 / 2002	I4503	80,4	6	04 / 2002				
E4107	60,21	1	04 / 2002	I5007	90,1	5	04 / 2002				